

Coverage chart n ≈ 2900 rpm

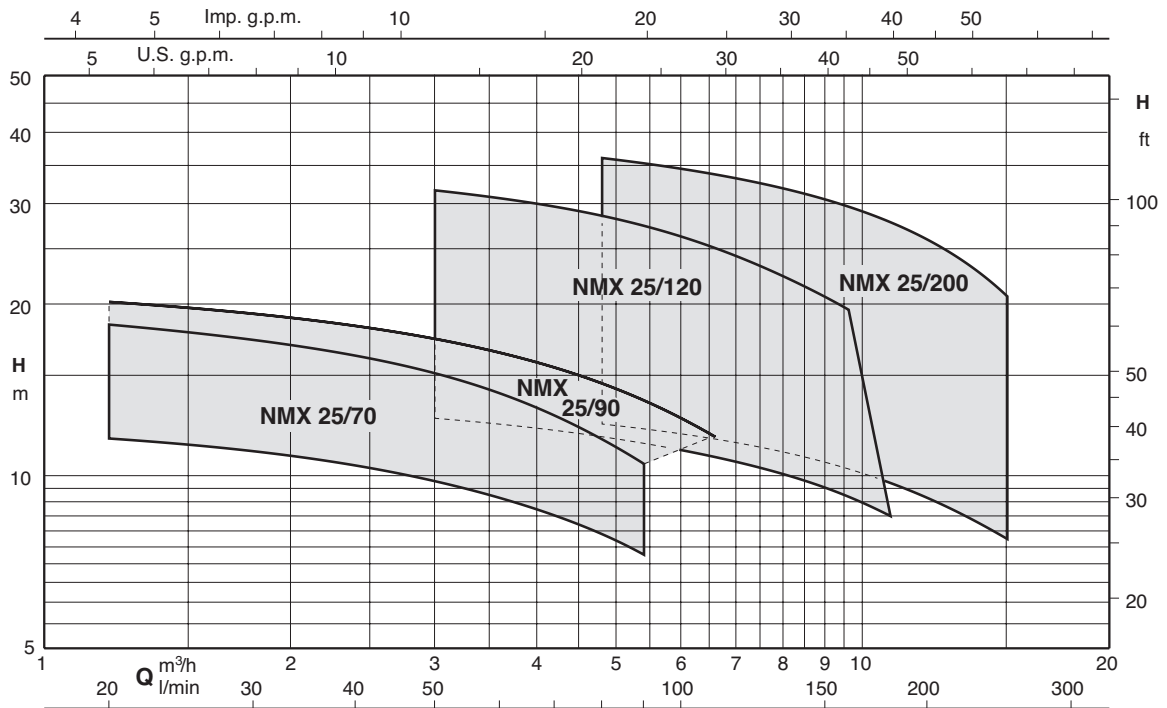

Close coupled centrifugal pumps with
threaded connections
stainless steel

Construction

Close-coupled, centrifugal pumps; electric motor with extended shaft directly connected to the pump.

Connections: threaded ports ISO 228/1 (BS 2779).

NMX: Version in AISI 304.

NMXL: Version in AISI 316.

Applications

For water supply.

For clean liquids, without abrasives, which are non-aggressive for stainless steel (with suitable seal materials, on request).

Universal pump, for domestic use, for civil and industrial applications, for garden use and irrigation.

Operating conditions

Liquid temperature from -10 °C to +90 °C.

Ambient temperature up to 40° C.

Maximum permissible working pressure up to 10 bar.

Continuous duty (S3 60% for single-phase pump to 1,5-1,8 kW).

Motor

2-pole induction motor, 50 Hz ($n \approx 2900$ rpm).

NMX: three-phase 230/400 V $\pm 10\%$.

NMXXM: single-phase 230 V $\pm 10\%$, with thermal protector.

Insulation class F.

Protection IP54

Motor suitable for operation with frequency converter from 1,1 kW.

IE2 efficiency class for single-phase motors up to 1,1 kW.

IE3 efficiency class for three-phase motors (IE2 up to 0,65 kW).

- Constructed in accordance with EN 60034-1, EN 60034-30-1, EN 60335-1, EN 60335-2-41.

Special features on request

Other voltages.

Frequency 60 Hz (as per 60 Hz data sheet).

IP protection: IP55

Special mechanical seal

Higher or lower liquid or ambient temperatures.

Motor suitable for operation with frequency converter up to 0,75 kW.

Designation

Example: NMX(L)M 25/70B/B

NMX = Series

L = Version in AISI 316.

M = Single-phase version (no indication: three-phase)

25 = Delivery port diameter in mm

70 = Hydraulic code

B = Impeller size

/B = It refers to a revision

The electropumps comply with the European Regulation no. 547/2012.

Materials

Components	NMX	NMXL
Pump casing	Chrome-nickel steel 1.4301 EN 10088 (AISI 304)	Stainless Steel 1.4401 EN 10088 (AISI 316)
Casing cover	Chrome-nickel steel 1.4301 EN 10088 (AISI 304)	Stainless Steel 1.4401 EN 10088 (AISI 316)
Impeller	Chrome-nickel steel 1.4301 EN 10088 (AISI 304)	Stainless Steel 1.4401 EN 10088 (AISI 316)
Shaft	Chrome-nickel steel 1.4301 EN 10088 (AISI 304)	Stainless Steel 1.4401 EN 10088 (AISI 316)
Wear ring	EPDM	EPDM
Mechanical seal	Ceramic alumina/Carbon/EPDM	Ceramic alumina/Carbon/EPDM

Coverage chart n ≈ 2900 rpm

Three-phase

Model						Q = Flow																			
						m³/h	H (m) = Total head																		
						l/min	0	1,2	1,5	1,89	2,4	3	3,6	4,2	4,8	5,4	6	6,6	7,5	8,4	9,6	10,8	12	13,2	15
230V	400V	P2		P1		0	20	25	31,5	40	50	60	70	80	90	100	110	125	140	160	180	200	220	250	
A	kW	HP	kW	HP																					
NMXL	NMX 25/70B	3	1,7	0,55	0,75		20,5	18,6	18,2	17,6	16,7	15,6	14,5	13,2	11,9	10,5	-	-	-	-	-	-	-	-	-
NMXL	NMX 25/70A	3,8	2,2	0,75	1		29,1	26,6	26,1	25,4	24,4	23,2	21,8	20,2	18,6	16,8	-	-	-	-	-	-	-	-	-
NMXL	NMX 25/90A	4,5	2,6	1,1	1,5		30	28,2	27,8	27,2	26,5	25,6	24,6	23,6	22,5	21,3	20	18,7	-	-	-	-	-	-	-
NMXL	NMX 25/120C	3,8	2,2	0,75	1		22,2	-	-	-	-	20	19,6	19,2	18,7	18,3	17,8	17,3	16,6	15,7	14,5	13,2	-	-	-
NMXL	NMX 25/120B	4,5	2,6	1,1	1,5		30,9	-	-	-	-	27,8	27,2	26,6	26	25,4	24,7	24	22,9	21,7	19,7	-	-	-	-
NMXL	NMX 25/120A	7,5	4,3	1,5	2		39,2	-	-	-	-	36	35,4	34,9	34,2	33,5	32,8	31,9	30,7	29,4	27,6	-	-	-	-
NMXL	NMX 25/200C	4,5	2,6	1,1	1,5		22,6	-	-	-	-	-	-	19,6	19,3	18,9	18,6	18	17,4	16,5	15,5	14,4	13,3	11,6	
NMXL	NMX 25/200B	7,5	4,3	1,5	2		32	-	-	-	-	-	-	29,5	29,2	28,8	28,4	27,9	27,2	26,3	25,3	24,3	23,1	21,2	
NMXL	NMX 25/200A	9,2	5,3	2,2	3		41,1	-	-	-	-	-	-	38,3	37,9	37,5	37,1	36,5	35,8	34,9	33,8	32,5	31,1	28,6	

Single-phase

Model						Q = Flow																			
						m³/h	H (m) = Total head																		
						l/min	0	1,2	1,5	1,89	2,4	3	3,6	4,2	4,8	5,4	6	6,6	7,5	8,4	9,6	10,8	12	13,2	15
230V	P2		P1																						
A	kW	HP	kW	HP																					
NMXLM	NMXM 25/70B	4,5	0,55	0,75	1		20,5	18,6	18,2	17,6	16,7	15,6	14,5	13,2	11,9	10,5	-	-	-	-	-	-	-	-	-
NMXLM	NMXM 25/70A	5,7	0,75	1	1,2		29,1	26,6	26,1	25,4	24,4	23,2	21,8	20,2	18,6	16,8	-	-	-	-	-	-	-	-	-
NMXLM	NMXM 25/90A	7	1,1	1,5	1,5		30	28,2	27,8	27,2	26,5	25,6	24,6	23,6	22,5	21,3	20	18,7	-	-	-	-	-	-	-
NMXLM	NMXM 25/120C	5,7	0,75	1	1,2		22,2	-	-	-	-	20	19,6	19,2	18,7	18,3	17,8	17,3	16,6	15,7	14,5	13,2	-	-	-
NMXLM	NMXM 25/120B	7	1,1	1,5	1,5		30,9	-	-	-	-	27,8	27,2	26,6	26	25,4	24,7	24	22,9	21,7	19,7	-	-	-	-
NMXLM	NMXM 25/120A	9,2	1,5	2	2		39,2	-	-	-	-	36	35,4	34,9	34,2	33,5	32,8	31,9	30,7	29,4	27,6	-	-	-	-
NMXLM	NMXM 25/200C	7	1,1	1,5	1,5		22,6	-	-	-	-	-	-	19,6	19,3	18,9	18,6	18	17,4	16,5	15,5	14,4	13,3	11,6	
NMXLM	NMXM 25/200B	9,2	1,5	2	2		32	-	-	-	-	-	-	29,5	29,2	28,8	28,4	27,9	27,2	26,3	25,3	24,3	23,1	21,2	

P1: Maximum power input.
P2: Rated motor power output.
H: Total head in m

Characteristic curves $n \approx 2900$ rpm

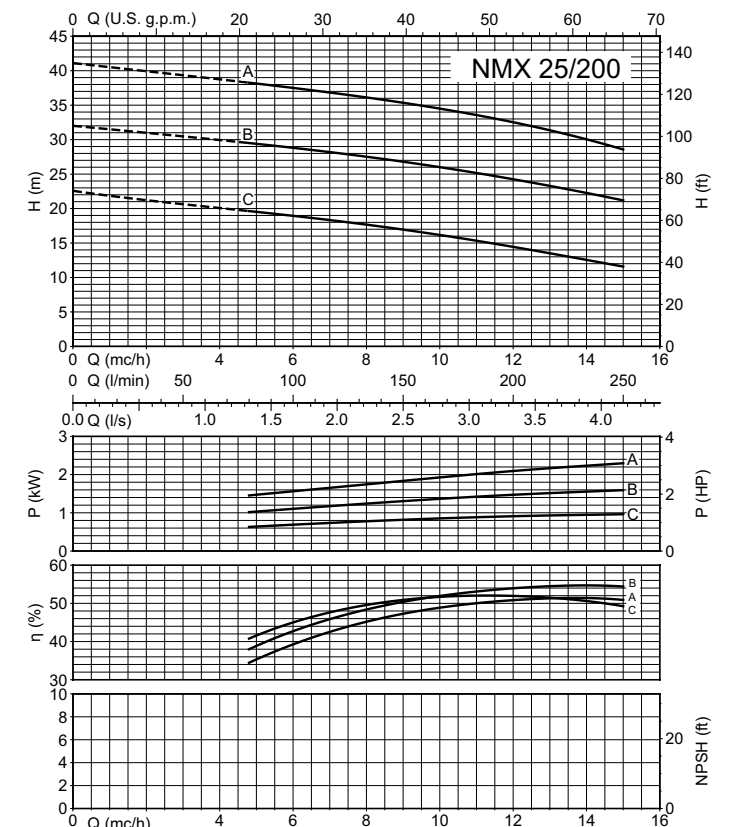
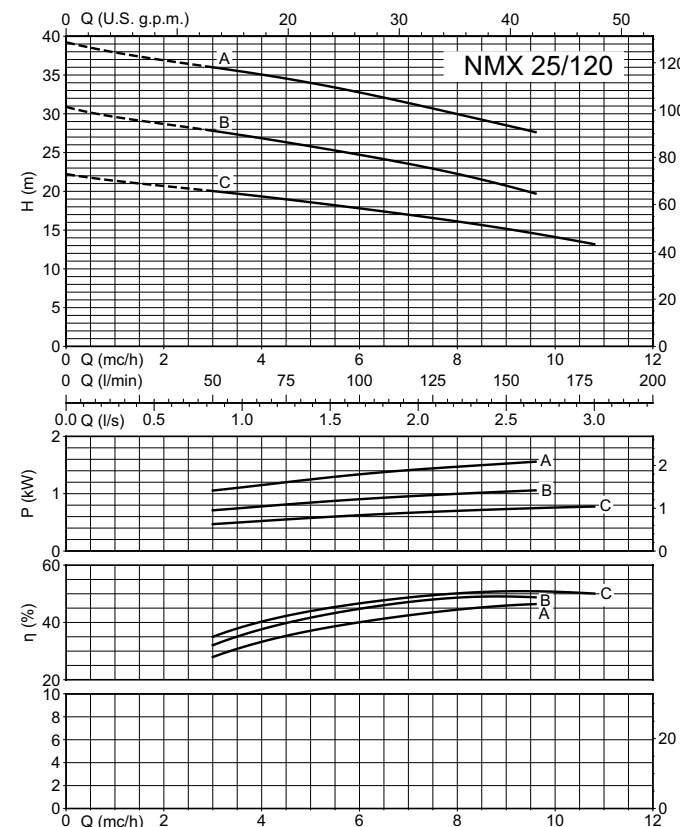
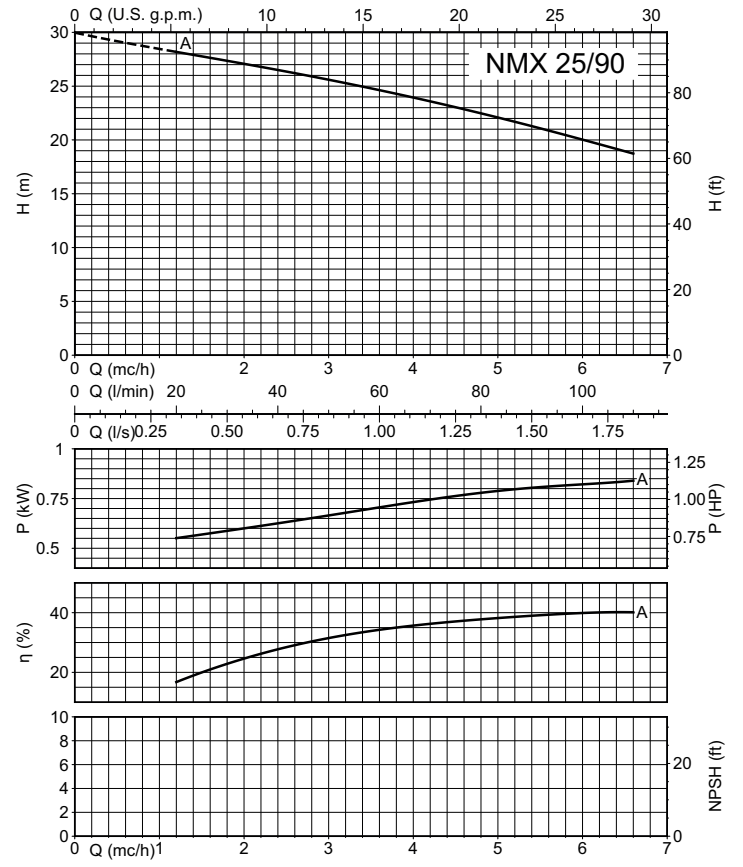
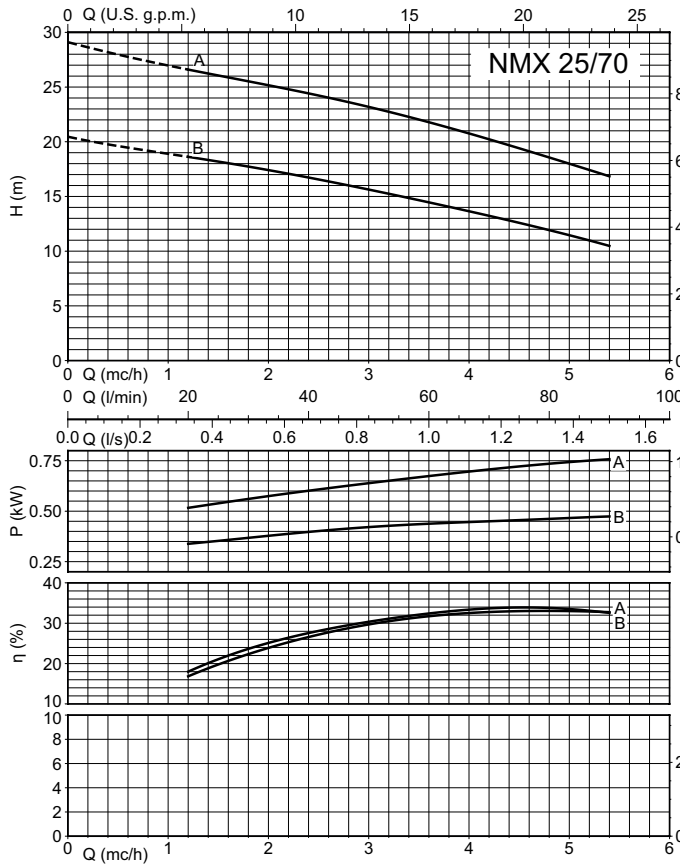

Dimensions and weight

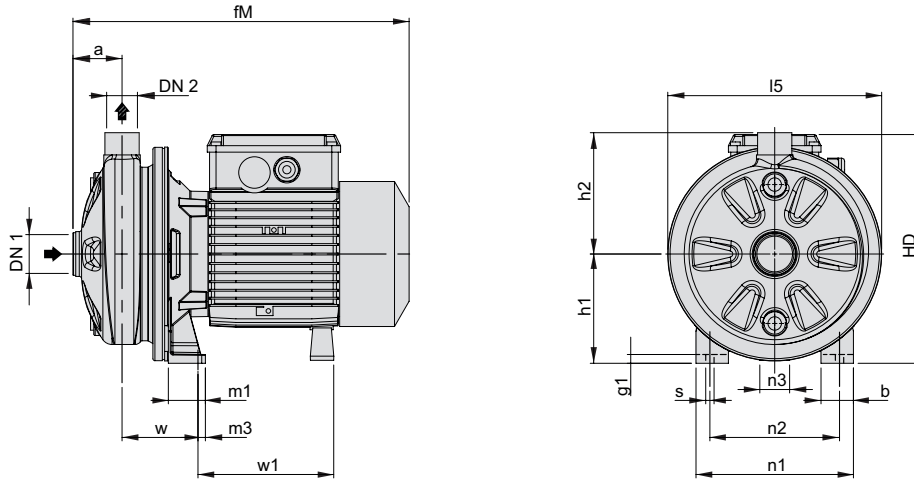

Three-phase

TYPE	ISO 228		mm															
	DN1	DN2	a	b	fM	g1	h1	h2	HD	l5	m1	m3	n1	n2	n3	s	w	w1
NMX 25/70B	G 1 1/4	G 1	53	35	329.5	10	106	123	217	208	40	8	170	140	20	9	80	135
NMX 25/70A	G 1 1/4	G 1	53	35	329.5	10	106	123	217	208	40	8	170	140	20	9	80	135
NMX 25/90A	G 1 1/4	G 1	53	35	329.5	10	106	123	217	208	40	8	170	140	20	9	80	135
NMX 25/120C	G 1 1/4	G 1	53	35	329.5	10	106	123	217	208	40	8	170	140	20	9	80	135
NMX 25/120B	G 1 1/4	G 1	53	35	329.5	10	106	123	217	208	40	8	170	140	20	9	80	135
NMX 25/120A	G 1 1/4	G 1	53	35	363	10	118	131	247	232	40	8	170	140	33	9	82	147
NMX 25/200C	G 1 1/2	G 1	53	35	329.5	10	106	123	217	208	40	8	170	140	20	9	80	135
NMX 25/200B	G 1 1/2	G 1	53	35	363	10	106	123	235	208	40	8	170	140	35	9	82	147
NMX 25/200A	G 1 1/2	G 1	53	35	403	10	118	131	247	232	40	8	170	140	35	9	82	187
NMXL 25/70B	G 1 1/4	G 1	53	35	329.5	10	106	123	217	208	40	8	170	140	20	9	80	135
NMXL 25/70A	G 1 1/4	G 1	53	35	329.5	10	106	123	217	208	40	8	170	140	20	9	80	135
NMXL 25/90A	G 1 1/4	G 1	53	35	329.5	10	106	123	217	208	40	8	170	140	20	9	80	135
NMXL 25/120C	G 1 1/4	G 1	53	35	329.5	10	106	123	217	208	40	8	170	140	20	9	80	135
NMXL 25/120B	G 1 1/4	G 1	53	35	329.5	10	106	123	217	208	40	8	170	140	20	9	80	135
NMXL 25/120A	G 1 1/4	G 1	53	35	363	10	118	131	247	232	40	8	170	140	33	9	82	147
NMXL 25/200C	G 1 1/2	G 1	53	35	329.5	10	106	123	217	208	40	8	170	140	20	9	80	135
NMXL 25/200B	G 1 1/2	G 1	53	35	363	10	106	123	235	208	40	8	170	140	35	9	82	147
NMXL 25/200A	G 1 1/2	G 1	53	35	403	10	118	131	247	232	40	8	170	140	35	9	82	187

Dimensions and weight

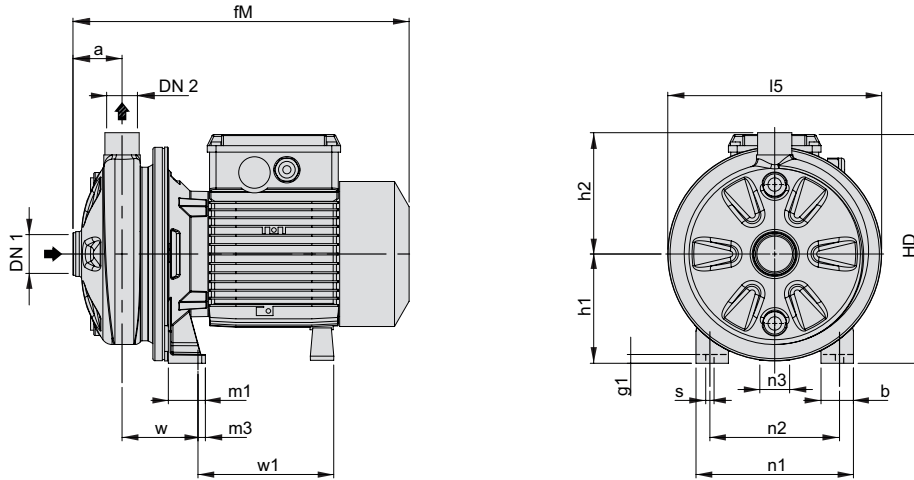

TYPE	ISO 228		mm															
	DN1	DN2	a	b	fM	g1	h1	h2	HD	l5	m1	m3	n1	n2	n3	s	w	w1
NMXM 25/70B	G 1 1/4	G 1	53	35	329.5	10	106	123	217	208	40	8	170	140	20	9	80	135
NMXM 25/70A	G 1 1/4	G 1	53	35	329.5	10	106	123	217	208	40	8	170	140	20	9	80	135
NMXM 25/90A	G 1 1/4	G 1	53	35	329.5	10	106	123	217	208	40	8	170	140	20	9	80	135
NMXM 25/120C	G 1 1/4	G 1	53	35	329.5	10	106	123	217	208	40	8	170	140	20	9	80	135
NMXM 25/120B	G 1 1/4	G 1	53	35	329.5	10	106	123	217	208	40	8	170	140	20	9	80	135
NMXM 25/120A	G 1 1/4	G 1	53	35	363	10	118	131	247	232	40	8	170	140	33	9	82	147
NMXM 25/200C	G 1 1/2	G 1	53	35	329.5	10	106	123	217	208	40	8	170	140	20	9	80	135
NMXM 25/200B	G 1 1/2	G 1	53	35	363	10	106	123	235	208	40	8	170	140	35	9	82	147
NMXLM 25/70B	G 1 1/4	G 1	53	35	329.5	10	106	123	217	208	40	8	170	140	20	9	80	135
NMXLM 25/70A	G 1 1/4	G 1	53	35	329.5	10	106	123	217	208	40	8	170	140	20	9	80	135
NMXLM 25/90A	G 1 1/4	G 1	53	35	329.5	10	106	123	217	208	40	8	170	140	20	9	80	135
NMXLM 25/120C	G 1 1/4	G 1	53	35	329.5	10	106	123	217	208	40	8	170	140	20	9	80	135
NMXLM 25/120B	G 1 1/4	G 1	53	35	329.5	10	106	123	217	208	40	8	170	140	20	9	80	135
NMXLM 25/120A	G 1 1/4	G 1	53	35	363	10	118	131	247	232	40	8	170	140	33	9	82	147
NMXLM 25/200C	G 1 1/2	G 1	53	35	329.5	10	106	123	217	208	40	8	170	140	20	9	80	135
NMXLM 25/200B	G 1 1/2	G 1	53	35	363	10	106	123	235	208	40	8	170	140	35	9	82	147