

TECHNICAL DATA

HYBRID - ASPHALT MANAGER 2

BW 174 ACP HYB

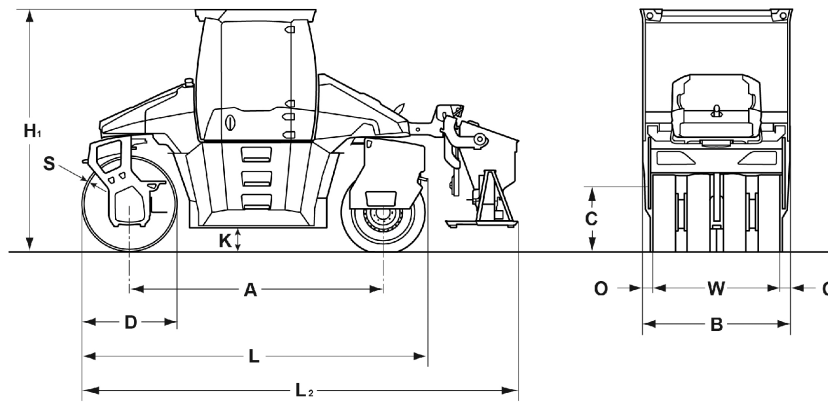



Dimensions in mm

	A	B	C	D	H1	K	L	L2	O	S	W
BW 174 ACP HYB	3220	1860	810	1200	3050	280	4420	5520	90	20	1680

Shipping dimensions in m3

BW 174 ACP HYB

with cabin

25,075

Machine type	Compaction output (t/h) at different asphalt layer thicknesses		
	2-4 cm	6-8 cm	10-14 cm
BW 174 ACP HYB	50-90	100-170	140-200

Technical Data

BOMAG BW 174 ACP HYB

Weights

Operating weight CECE w. ROPS-cabin	kg	9.300
Static linear load CECE	kg/cm	29,8
Axle load, drum CECE	kg	5.000
Axle load, wheels CECE	kg	4.300
Max. weight	kg	12.500
Wheel load CECE	kg	1.100

Dimensions

Track radius, inner	mm	2.970
---------------------------	----	-------

Driving Characteristics

Speed	km/h	0- 11,0
-------------	------	---------

Drive

Engine manufacturer		Kubota
Type		V3307 -T
Emission stage		Stage V / TIER4f
Exhaust gas aftertreatment		DOC+DPF
Cooling		Liquid
Number of cylinders		4
Performance ISO 14396	kW	55,4
Performance SAE J 1995	hp	74,2
Performance HYBRID	kW	20,0
System performance	kW	75,4
Speed	min-1	2.400

Drums and Tyres

Drum width	mm	1.680
Number of tyres		4
Split drum		front

Brakes

Service brake		hydrost.
Parking brake		mech.

Steering

Steering system		2-p. pivoted
Lateral displacement right/left	mm	1.360

Exciter system

Construction		Directed exciter standard
Autom. vibr. shut off		
Frequency	Hz	45
Amplitude	mm	0- 0,83
Amplitude	mm	0,83
Centrifugal force	kN	145

Capacities

Fuel	l	180,0
Water	l	680,0
Emulsion	l	32,0

Technical modifications reserved. Machines may be shown with options.

Standard Equipment

- ECOMODE
- ASPHALT MANAGER
- 10" Touchscreen
- Oscillation mode
- Highly wear resistant AM drum
- Water-saving pressure sprinklers
- Pressure sprinkler system Emulsion
- 1 Directed exciter, front
- 2 spring-loaded hinged scrapers
- Autom. vibration operation
- Indicator and hazard lights
- ROPS cabin with seat belts
+ heating
- 2 Outside mirrors
- Steering method/Operator's seat sliding /
rotatable (270°)
- Steering with comfort control
- 5 Steering modes
- Back-up alarm
- Brake release device
- Split drums
- Emergency STOP

Optional Equipment

- Edge cutter
- Rotary beacon
- Special paint
- Environmentally compliant hydraulic oil
- Tool kit
- Precision spreader
- Precision spreader laterally slidable
- Automatic air conditioning
- Thermal aprons
- Radio/Radio preparation
- LED lighting package
 - additional lateral lighting for cabin
 - Follow-me-home function
 - Lighting for drum edge
 - 2x 12V sockets in supports
- Backup warning buzzer with broadband
technology
- Additional outside mirrors
- Air-suspended comfort seat
- BOMAG TELEMATIC POWER
- BOMAP compaction navigation with GPS
- JOBLINK measuring technology interface
- BOMAP GPS antenna set
- BOMAP GPS antenna holder
- ECOSTOP

