



O & M Manual



Model Q45S/87 Portable Wet Hydrogen Sulfide Measurement System

Home Office

Analytical Technology, Inc.
6 Iron Bridge Drive
Collegeville, PA 19426
Phone: 800-959-0299
610-917-0991
Fax: 610-917-0992
Email: sales@analyticaltechnology.com

European Office

ATI (UK) Limited
Unit 1 & 2 Gatehead Business Park
Delph New Road, Delph
Saddleworth OL3 5DE
Phone: +44 (0)1457-873-318
Fax: + 44 (0)1457-874-468
Email: sales@atiuk.com

Table of Contents

PART 1 - INTRODUCTION	4	PART 8 – TROUBLESHOOTING	36
1.1 GENERAL	4	8.1 GENERAL	36
1.2 FEATURES	5	8.2 EXTERNAL SOURCES OF PROBLEMS	36
1.4 Q45S/87 SYSTEM SPECIFICATIONS	6	8.3 ANALYZER TESTS	36
1.5 Q45S/87 PERFORMANCE SPECIFICATIONS	7	8.4 DISPLAY MESSAGES	37
PART 2 – ANALYZER CONFIGURATION	8	SPARE PARTS	38
2.1 GENERAL	8		
PART 3 – SENSOR INSTALLATION	9		
3.1 GENERAL	9		
3.2 SENSOR DUCT ASSEMBLY	9		
3.3 SENSOR PREFILTER MEMBRANE	11		
PART 4 – ELECTRICAL INSTALLATION	12		
4.1 GENERAL	12		
4.2 CABLE CONNECTION	12		
PART 5 – OPERATION	14		
5.1 USER INTERFACE	14		
5.2 BATTERY / POWER CIRCUIT BOARD	14		
5.3 BATTERY POWER CIRCUIT BOARD	16		
5.4 VOLTAGE OUTPUTS	16		
5.5 USER INTERFACE	16		
5.6 KEYS	18		
5.7 DISPLAY	18		
5.8 SOFTWARE	20		
5.9 SOFTWARE NAVIGATION	20		
5.10 MEASURE MENU [MEASURE]	23		
5.11 CALIBRATION MENU [CAL]	23		
5.12 CONFIGURATION MENU [CONFIG]	25		
5.13 CONTROL MENU [CONTROL]	27		
5.14 DIAGNOSTICS MENU [DIAG]	28		
PART 6 – CALIBRATION	31		
6.1 CALIBRATION	31		
6.2 ZERO CAL	31		
6.3 SPAN CAL	32		
6.4 TEMPERATURE CALIBRATION	33		
PART 7 – SYSTEM MAINTENANCE	35		
7.1 GENERAL	35		
7.2 ANALYZER MAINTENANCE	35		
7.3 SENSOR MAINTENANCE	35		

Table of Figures

<i>FIGURE 1 - PORTABLE TYPICAL CONFIGURATION</i>	<i>8</i>
<i>FIGURE 2 - DUCT INSERTION SENSOR HOLDER DIMENSIONS</i>	<i>9</i>
<i>FIGURE 3 - DUCT SENSOR HOLDER EXPLODED VIEW.....</i>	<i>10</i>
<i>FIGURE 4 - SENSOR CABLE PREPARATION</i>	<i>12</i>
<i>FIGURE 5 - SENSOR CALIBRATION DIAGRAM.....</i>	<i>13</i>
<i>FIGURE 6 - BATTERY BOARD CONNECTIONS.....</i>	<i>15</i>
<i>FIGURE 7 - USER INTERFACE.....</i>	<i>17</i>
<i>FIGURE 8 - SOFTWARE MAP</i>	<i>22</i>
<i>FIGURE 9 - Q45H DISPLAY MESSAGES</i>	<i>37</i>

Part 1 - Introduction

1.1 General

The Q45S/87 Wet H₂S Transmitter is a versatile portable monitoring/recording instrument for hydrogen sulfide gas in wet scrubber outlet vents or scrubber inlet ducts saturated with water vapor.

The system operates on two AA batteries, and will run continuously for approximately 240 hours.



Warning: If unit is to be stored for more than 6 months REMOVE the batteries from the holder to avoid potential damage from battery leakage.

1.2 Standard System

The system consists of two parts, a Portable Monitor assembly and a special H₂S sensor with duct insertion holder designed for operation in condensing gas streams.

For connection of the sensor to the electronics, a 25' cable is supplied. All required spare parts are also provided with the basic system, including spare membranes, electrolyte, o-rings, and any special hardware.

1.2 Features

- Standard Q45S/87 are designed to be fully isolated, battery powered instruments for monitoring/recording applications. Can be Quickly converted to either a loop power transmitter or line powered analyzer (optional board required for analyzer)
- High sensitivity system measures from 0.1 ppm to 200.0 ppm with 3 display ranges. User ranges of 2.000 ppm, 20.00 ppm, or 200.0 ppm may be selected, or the monitor may operate in Auto-Ranging mode, switching display sensitivity up and down depending on the measured value.
- Two 10-bit isolated, 0-2.5 VDC outputs may be configured to track Hydrogen Sulfide and temperature, or Hydrogen Sulfide or Hydrogen Sulfide. Both outputs can be programmed individually to specific ranges.
- Large, high contrast, custom LCD display with LED back light provides excellent readability. The secondary line of display utilizes 5x7 dot matrix characters for clear message display. Two of four measured parameters may be on the display simultaneously. An LED backlight can be turned on if necessary for use in very low light conditions.
- Diagnostic messages provide a clear description of any problem with no confusing error codes to look up. Messages are also included for diagnosing calibration problems.
- Quick and easy one-point calibration method and sensor zero-cal. To provide high accuracy, all calibration methods include stability monitors that check main parameter stability before accepting data.
- Security lock feature to prevent unauthorized tampering with transmitter settings. All settings can be viewed while locked, but they cannot be changed.

1.4 Q45S/87 System Specifications

Displayed Parameters	Main input, 0.1 ppm to 200.0 ppm Sensor Current, 0.0 to 999.9 nA, 0.000 to 99.99 uA Sensor Temperature 0-2.5V Outputs Sensor slope/offset Model number and software version
Main Parameter Ranges	Manual selection of one of the following ranges, 0.0 to 2.000 ppm 0.00 to 20.00 ppm 0.00 to 200.0 ppm
Display	0.75" (19.1 mm) high 4-digit main display with sign 12-digit secondary display, 0.3" (7.6 mm) 5x7 dot matrix. Integral LED back-light for visibility in the dark.
Keypad	4-key membrane type with tactile feedback, polycarbonate with UV coating
Weight	0.8 lbs. (0.36 Kg.)
Ambient Temperature	Analyzer Service, -20 to 60 °C (-4 to 140 °F) Sensor Service, -5 to 55°C (23 to 131°F) Storage, -5 to 70 °C (-22 to 158 °F)
Ambient Humidity	0 to 95%, non-condensing.
EMI/RFI Influence	Designed to EN 61326-1
Output Isolation	600 V galvanic isolation
Filter	Adjustable 0-9.9 minutes additional damping to 90% step input
Sensor	Electrochemical type for measurement of hydrogen sulfide gas
Sensor Materials	Noryl and PVC
Sensor Cable	25 ft. (7.5 meter) cable

Sensor Holder	PVC duct insertion assembly with air-purge nozzle.
Power:	Two generic AA batteries, low battery indication at 1.60V DC.
Enclosure:	NEMA 4X, IP66, polycarbonate, stainless steel hardware, weatherproof and corrosion resistant, HWD: 4.4" (112 mm) x 4.4" (112 mm) x 3.5" (89 mm)
Mounting Options	Supplied with carrying handle and cable glands installed.
Outputs:	Two 0-2.5 VDC isolated outputs are provided on for connection to data recorders, etc.
Battery Life:	Approximately 240 hours of operational use on a set of batteries (without backlight).

1.5 Q45S/87 Performance Specifications

(Common to all variations)

Accuracy	1% of selected range or 0.2 PPM
Repeatability	0.5% of selected range or 0.1 PPM
Sensitivity	0.05% of selected range
Non-linearity	0.1% of selected range
Warm-up Time	3 seconds to rated performance (electronics only)
Supply Voltage Effects	± 0.05% span
Instrument Response Time	60 seconds to 90% of step input at lowest damping

Part 2 – Analyzer Configuration

2.1 General

The Q45S/87 Portable Wet Hydrogen Sulfide System comes complete with a specially designed handle that allows the system to be comfortably carried, or quickly strapped to a railing. Although the system is designed to be a portable system, it can be permanently mounted for longer term field use. This is possible due to the very long battery life spans that can be achieved with the system.

2.2 Portable Handle

A removable handle is included with each unit that provides not only comfortable transportation of the system, but the integral locking strap allows the system to be quickly mounted to pipes or rails for longer term use in one area.

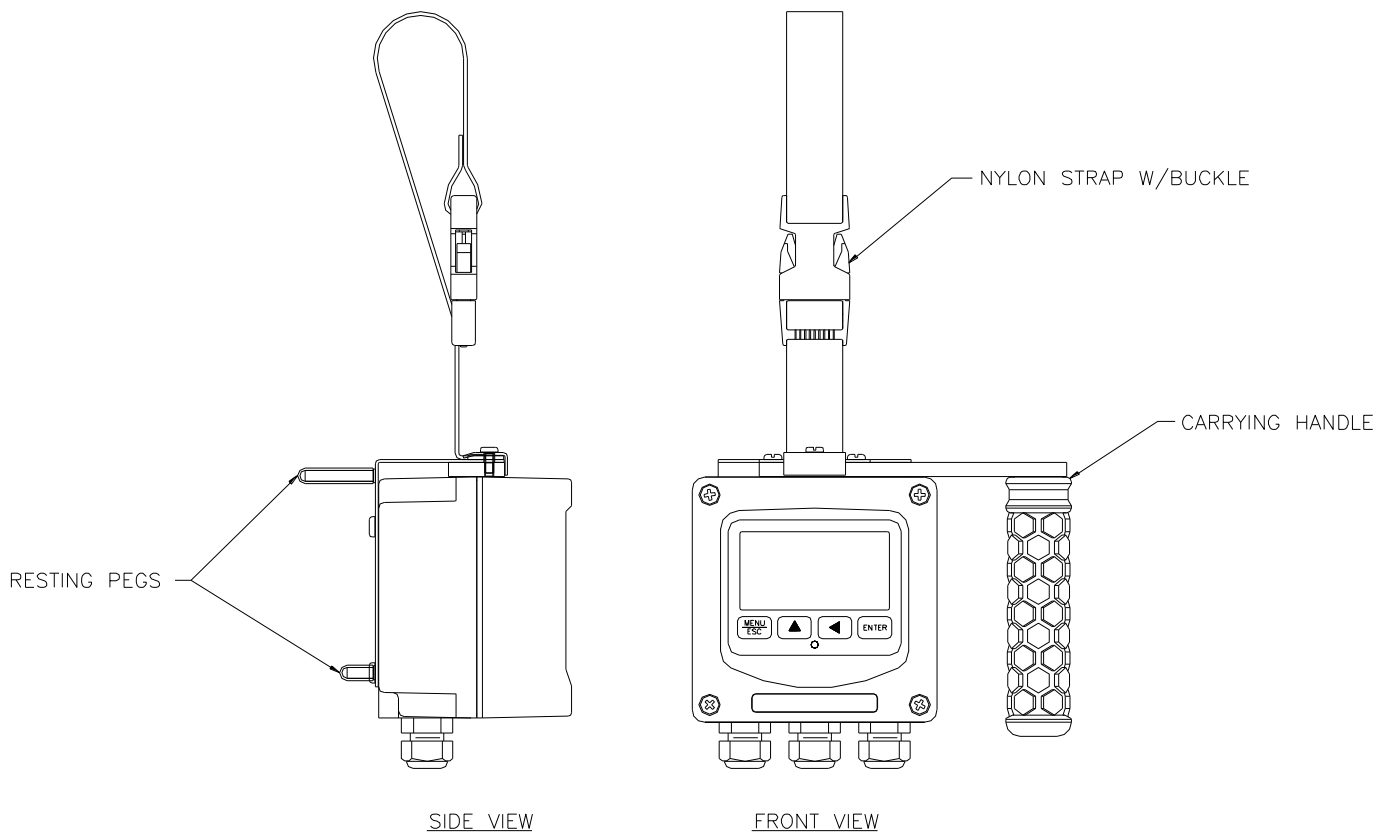

Figure 1 - Portable Typical Configuration

Part 3 – Sensor Installation

3.1 General

Select a location for the sensor on the side of the scrubber inlet or outlet duct. Do not mount the sensor on the bottom of a horizontal duct section. If the duct is horizontal, mount the sensor at about 45-60 degrees off of vertical. **The preferred location for mounting the sensor is on a VERTICAL section of duct.** Always select a location that allows for easy access to the sensor for maintenance purposes. Placing the sensor in an inaccessible location generally leads to a lack of maintenance and ultimate failure of the system.

3.2 Sensor Duct Assembly

Figure 2 shows the dimensions of the duct mount assembly used to insert the wet hydrogen sulfide sensor into a scrubber duct. This assembly is designed to be screwed into a 1½" NPT female adapter on the duct. The female adapter attached to the duct must be supplied by the user.

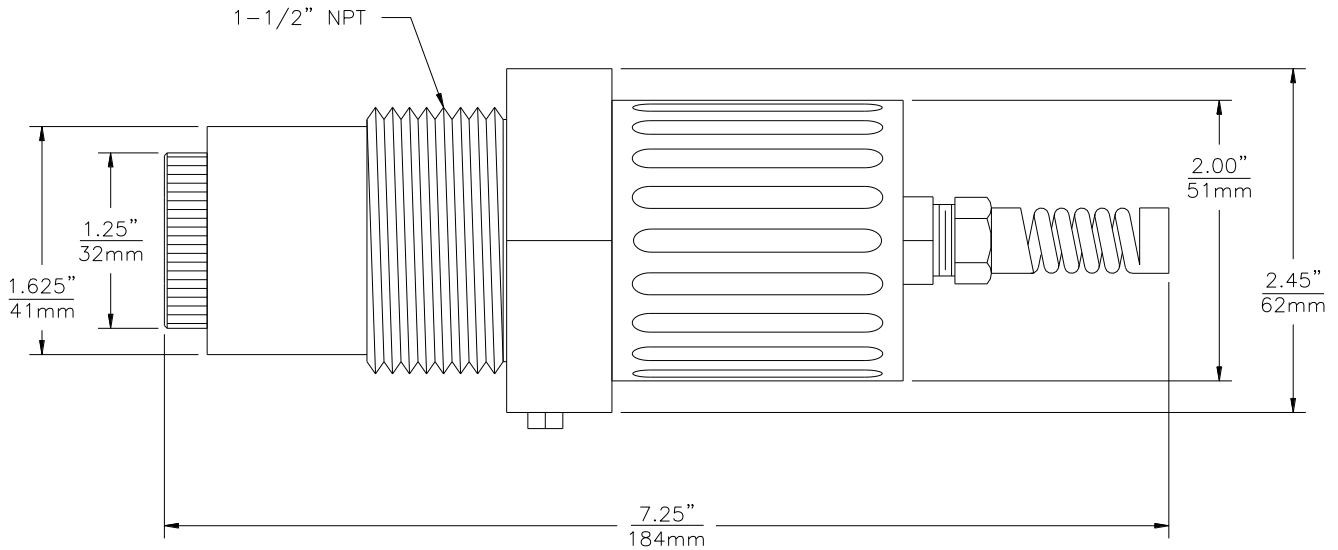

Figure 2 - Duct Insertion Sensor Holder Dimensions

Figure 3 shows an exploded view of the duct insertion assembly with the hydrogen sulfide sensor and cable assembly.

To facilitate installation, disassemble the sensor system so that the front half of the holder can be screwed into the duct separately.

The front section of the sensor holder assembly is screwed to the duct, and it will need to be removed periodically to replace the prefilter membrane. Apply teflon tape to the threads prior to installation and screw this part in “hand tight” to allow for easy removal.

When taking the sensor assembly apart, first loosen the cable gland at the back of the adapter so that cable can slide freely. Then unscrew the adapter from the front holder. The sensor can be pulled out from the holder using the cable. When inserting the sensor, connect the sensor cable first and use the connector to press the sensor firmly into place. An o-ring at the front of the holder seals the compartment. A small amount of o-ring lubricant on the side of the front section of the sensor will make insertion and removal much easier. Screw the adapter back in and then tighten the cable gland to seal the cable against water intrusion.

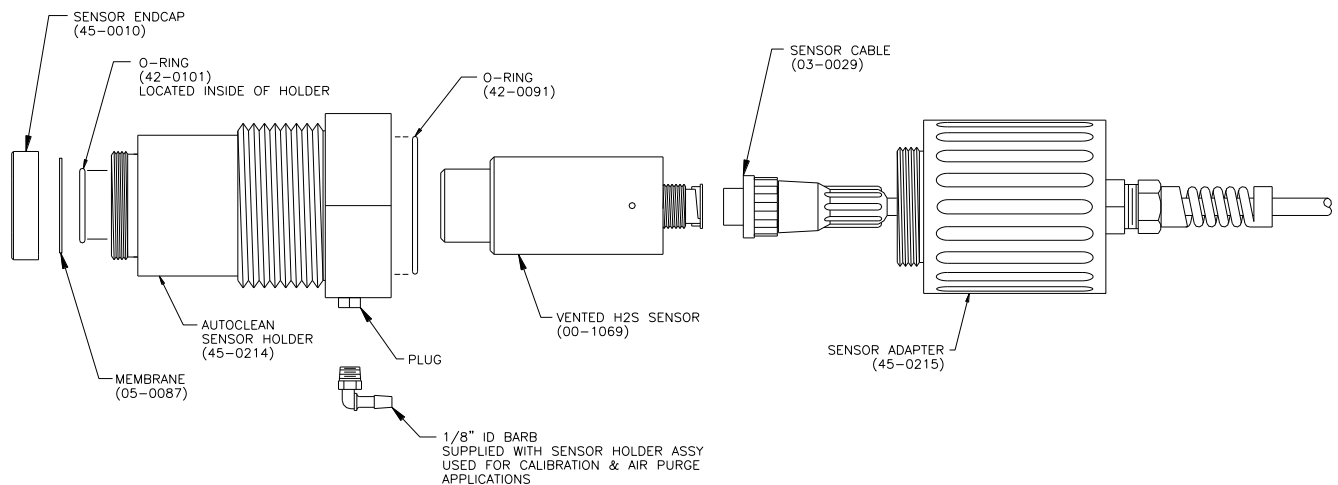

Figure 3 - Duct Sensor Holder Exploded View

3.3 Sensor Prefilter Membrane

On the front of the sensor holder is a membrane that serves as a sample prefilter to protect the sensor from deposits that could cause premature sensor failure. This membrane is held in place with a screw-on cap, and the membrane should be changed every 2 or 3 months to insure proper operation of the system. A package of 10 prefilter membranes are supplied with the unit.

The membrane material used as a prefilter IS NOT the same on both sides. Look carefully at one of the membrane disks and you will see a mesh pattern on one side. You can also feel the difference between the two sides. The mesh side is fairly smooth while the opposite side is slightly sticky, feeling a little like a latex glove. **When installing the prefilter on the sensor holder, the mesh side of the membrane must face out toward the measured air stream.**

Prefilters are available in packages of 10. The part number is listed on the spare parts page of this manual.

Part 4 – Electrical Installation

4.1 General

The sensor cable can be quickly connected to the Q45 terminal strip by matching the wire colors on the cable conductors.

4.2 Cable Connection

The sensor cable should be routed into the enclosure through the right hand cord grip on the bottom of the enclosure. Make sure the cord-grips are snugly tightened after electrical connections have been made to prevent moisture incursion. When stripping cables, leave adequate length for connections in the transmitter enclosure, as shown below.

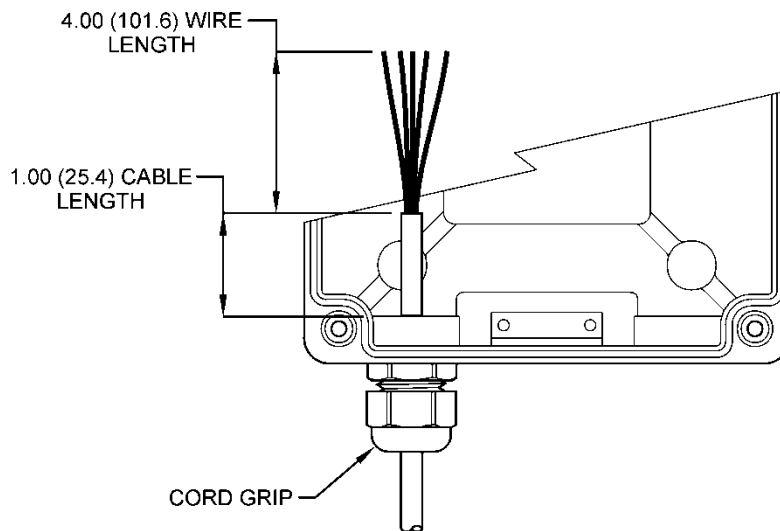

Figure 4 - Sensor Cable Preparation

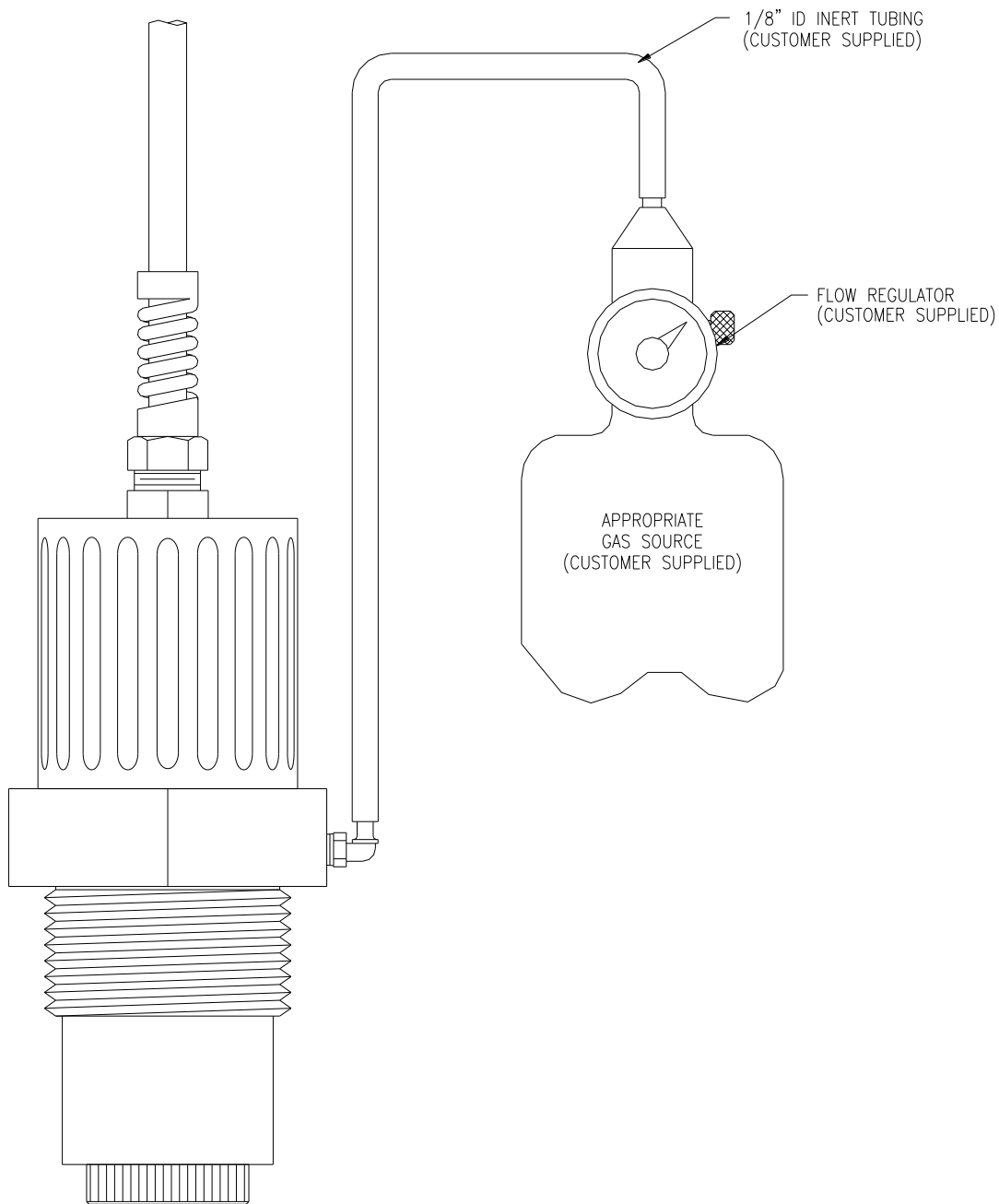

Figure 5 - Sensor Calibration Diagram

Part 5 – Operation

5.1 User Interface

Note: Upon receipt of analyzer for the first time, you will need to open up the transmitter and the PWR (S1) switch needs to be flipped from OFF to ON. Unit shipped in the OFF position to avoid possible battery drainage due to accidental Starting of analyzer.

To turn the system ON, simply press and hold the MENU key for approximately 5 seconds and the display will come on. **To turn the unit off, press and hold the ENTER key until the display shuts off (about 3 seconds). Note that the unit must be in the MEASURE menu in order for the 3-second key press to operate.**The instrument will turn off automatically after 30 minutes if no keys are pressed – optimizing battery life. This mode of operation is ideal for portable operation where intermediate readings are being taken. Assuming the instrument is used perhaps an hour per day, this would result in a battery lifespan of about 240 hours. For continuous operation with no automatic shut-off, turn the Auto-OFF feature to OFF in the DIAG menu. This mode is intended for use when the instrument outputs are used for transmitting data. In this mode, the instrument will run continuously until the battery reaches the shut-down level (1.6V). It should be noted that rechargeable AA batteries reduce operational times dramatically, as they typically contain much less energy than standard batteries.

The PWR switch disconnects the AA batteries and is only used to disconnect the battery if the system is not to be used for a long period of time (> 3 months of storage). Otherwise, leave this switch in the ON position. The red dip switch is only for factory use.

The "B" will flash on the display next to the main measurement indication when the instrument requires battery replacement. If the battery is not replaced, eventually the unit may not turn on in the normal operating mode. Once the low battery condition is indicated, the instrument will only stay powered for 10 minutes.

5.2 Battery / Power Circuit Board

Q45S monitors are powered by internal AA alkaline batteries Figure 5 shows this board assembly with batteries installed.

The battery circuit board contains 3 switch assemblies as shown in the drawings.

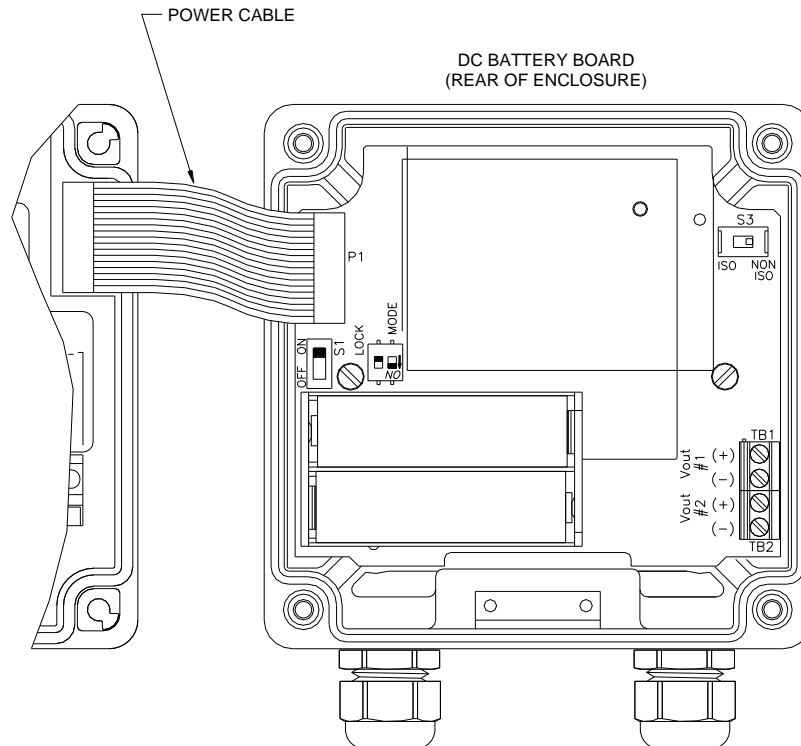

Figure 6 - Battery Board Connections

The first (**S1**) is an On/Off slide switch. This switch must be in the ON position for operation. Turn it to OFF if you do not intend to operate the monitor in the next week or two.

The second switch assembly (**S2**) contains two switches, the one on the left marked LOCK and the one on the right marked MODE. The function of these two slide switches are as follow:

LOCK This switch is used to define how the monitor will turn on and off. This switch is normally in the OFF position. With the lock switch off, the monitor will be turned on manually using the MENU key on the front of the monitor. With the lock switch in the ON position, the monitor will always be on when there is enough power to run the monitor. The ON position is normally used when operating from an external power supply intended for continuous operation.

MODE This switch is used to set the voltage at which monitor will shut off when powered by internal batteries. Alkaline batteries can normally be run down to about 0.8 volts. When using alkaline batteries, the mode switch is in the OFF position (factory default). If rechargeable NiMH batteries are substituted, place the MODE

switch in the ON position. Note that rechargeable NiMH batteries have only about 35% of the capacity of an alkalines. However, NiMH batteries can be recharged hundreds of times.

The third switch assembly is a single slide switch (**S3**) which defines whether the 0-2.5 VDC signals from the monitor are isolated or non-isolated. Output isolation is not required when outputs are connected to the internal data logger. However, if the outputs are connected to external devices through the external connection cable, putting this switch in the ISO position will protect against possible ground loops. The isolation circuit will slightly increase the power requirement for the monitor, resulting in a bit less battery life.

5.3 Battery Power Circuit Board

The Q45 portable instrument is primarily operated by software settings. However, there are also a few hardware details on the battery circuit board to note.

The battery board is a circuit board that sits in the rear of the Q45 enclosure, and connects to the Q45 AUX port through a ribbon cable. The battery board contains the battery clip for the two AA batteries and the output terminal strip for the two 0-2.5 VDC outputs. Along the left side below the ribbon cable is an ON/OFF slide switch. This switch can be used to turn the instrument completely OFF when not intending to use the unit for an extended period.

5.4 Voltage Outputs

There are two sets of analog voltage outputs on the battery board that may be used to send isolated data back to remotely located recorders, PLC's, etc. Output #1 is used only for hydrogen sulfide information, and Output #2 can be used for an additional hydrogen sulfide output channel, or it can be selected to output temperature information.

5.5 User Interface

The user interface for the Q45 Series instrument consists of a custom display and a membrane keypad. All functions are accessed from this user interface (no internal jumpers, pots, etc.).

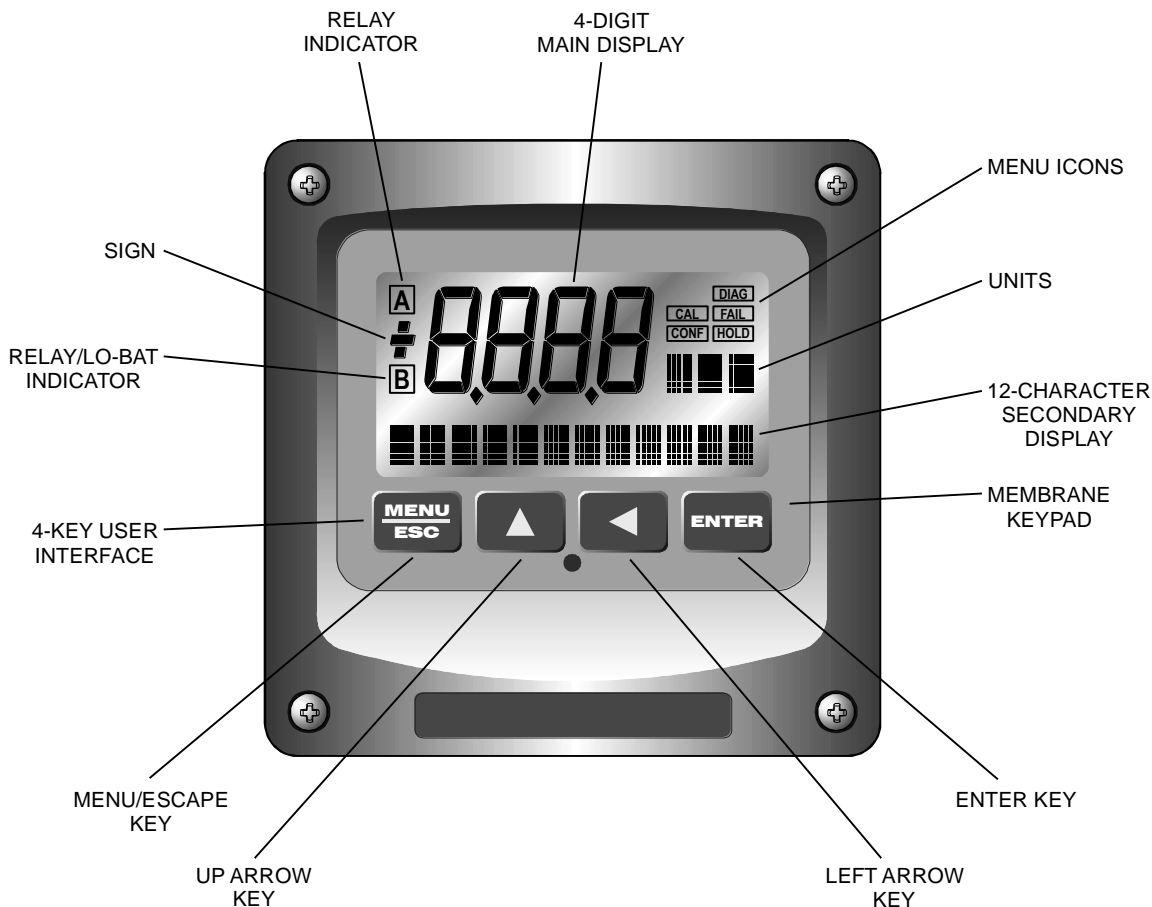

Figure 7 - User Interface

5.6 Keys

All user configurations occur through the use of four membrane keys. These keys are used as follows:

- | | |
|---------------------|---|
| MENU/ESC | To scroll through the menu section headers or to escape from anywhere in software. The escape sequence allows the user to back out of any changes in a logical manner. Using the escape key aborts all changes to the current screen and backs the user out one level in the software tree. The manual will refer to this key as either MENU or ESC, depending upon its particular function. In the battery-powered version of the Q45, this is also the ON button. |
| UP (arrow) | To scroll through individual list or display items and to change number values. |
| LEFT (arrow) | To move the cursor from right to left during changes to a number value. |
| ENTER | To select a menu section or list item for change and to store any change. |

5.7 Display

The large custom display provides clear information for general measurement use and user configuration. There are three main areas of the display: the main parameter display, the secondary message line, and the icon area.

Main Parameter During normal operation, the main parameter display indicates the present process input with sign and units. This main display may be configured to display any of the main measurements that the system provides. During configuration, this area displays other useful set-up information to the user.

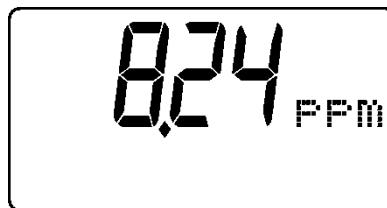

Lower Line

During normal operation, the lower line of the display indicates user-selected secondary measurements that the system is making. This also includes calibration data from the last calibration sequence and the transmitter model number and software version. During configuration, the lower line displays menu items and set-up prompts to the user. Finally, the lower line will display error messages when necessary. For a description of all display messages, refer to Display Messages under the Troubleshooting section of this manual.

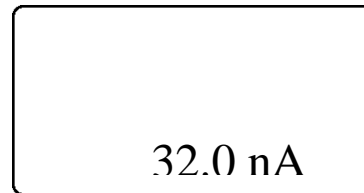
**Icon Area**

The icon area contains display icons that assist the user in set-up and indicate important states of system functions. The CAL, CONFIG, and DIAG icons are used to tell the user what branch of the software tree the user is in while scrolling through the menu items. This improves software map navigation dramatically. Upon entry into a menu, the title is displayed (such as CAL), and then the title disappears to make way for the actual menu item. However, the icon stays on.

**HOLD**

The HOLD icon indicates that the current output of the transmitter has been put into output hold. In this case, the output is locked to the last input value measured when the HOLD function was entered. HOLD values are retained even if the unit power is cycled.

FAIL

The FAIL icon indicates that the system diagnostic function has detected a problem that requires immediate attention. This icon is automatically cleared once the problem has been resolved.

ICON B

The left screen area contains one “B” icon that indicates that the battery voltage is at a low level.

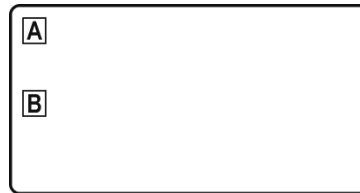
**5.8 Software**

The software of the Q45H is organized in an easy to follow menu-based system. All user settings are organized under five menu sections: Measure, Calibration [CAL], Configuration [CONFIG], Control [CONTROL] and Diagnostics [DIAG].

Note: The default Measure Menu is display-only and has no menu icon.

5.9 Software Navigation

Within the CAL, CONFIG, CONTROL, and DIAG menu sections is a list of selectable items. Once a menu section (such as CONFIG) has been selected with the MENU key, the user can access the item list in this section by pressing either the ENTER key or the UP arrow key. The list items can then be scrolled through using the UP arrow key. Once the last item is reached, the list wraps around and the first list item is shown again. The items in the menu sections are organized such that more frequently used functions are first, while more permanent function settings are later in the list. See Figure 8 - Software Map for a visual description of the software.

Each list item allows a change to a stored system variable. List items are designed in one of two forms: simple single variable, or multiple variable sequences. In the single variable format, the user can quickly modify one parameter - for example, changing the display range from 2.000 to 20.00. In the multiple variable sequence, variables are changed as the result of some process. For example, the calibration of hydrogen sulfide generally requires more than one piece of information to be entered. The majority of the menu items in the software consist of the single variable format type.

Any data that may be changed will be flashing. This flashing indicates user entry mode and is initiated by pressing the ENTER key. The UP arrow key will increase a flashing digit from 0 to 9. The LEFT arrow key moves the flashing digit from right to left. Once the change has been completed, pressing ENTER again stores the variable and stops the flashing. Pressing ESC aborts the change and also exits user entry mode.

The starting (default) screen is always the Measure Menu. The UP arrow key is used to select the desired display. From anywhere in this section the user can press the MENU key to select one of the four Menu Sections.

The UP arrow icon next to all list items on the display is a reminder to scroll through the list using the UP arrow key.

To select a list item for modification, first select the proper menu with the MENU key. Scroll to the list item with the UP arrow key and then press the ENTER key. This tells the system that the user wishes to perform a change on that item. For single item type screens, once the user presses the ENTER key, part or all of the variable will begin to flash, indicating that the user may modify that variable using the arrow keys. However, if the instrument is locked, the transmitter will display the message **Locked!** and will not enter user entry mode. The instrument must be unlocked by entering the proper code value to allow authorized changes to user entered values. Once the variable has been reset, pressing the ENTER key again causes the change to be stored and the flashing to stop. The message **Accepted!** will be displayed if the change is within pre-defined variable limits. If the user decides not to modify the value after it has already been partially changed, pressing the ESC key aborts the modification and returns the entry to its original stored value.

In a menu item which is a multiple variable sequence type, once the ENTER key is pressed there may be several prompts and sequences that are run to complete the modification. The ESC key can always be used to abort the sequence without changing any stored variables.

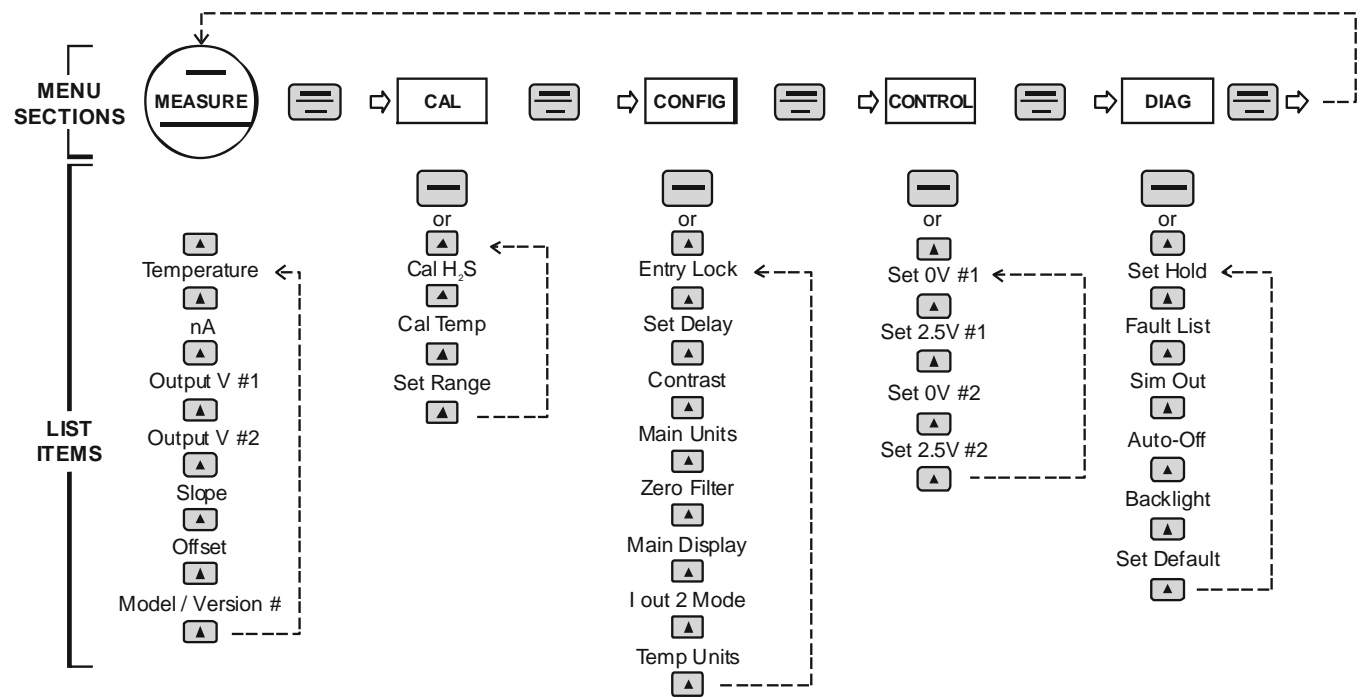

Figure 8 - Software Map

5.10 Measure Menu [MEASURE]

The default menu for the system is the display-only menu MEASURE. This menu is a display-only measurement menu, and has no changeable list items. When left alone, the instrument will automatically return to this menu after approximately 30 minutes. While in the default menu, the UP arrow allows the user to scroll through the secondary variables on the lower line of the display. A brief description of the fields in the basic transmitter version is as follows:

TRANSMITTER MEAS SCREENS:

25.7C	Temperature display. Can be displayed in °C or °F, depending on user selection. A small “m” on the left side of the screen indicates the transmitter has automatically jumped to a manual 25C setting due to a failure with the temperature signal input.
32.0 nA	Raw sensor current. Useful for diagnosing problems.
#1 1.05 VDC	Instrument output signal #1.
#2 0.66 VDC	Instrument output signal #2.
Slope = 100%	Sensor output response vs. ideal calibration. This value updates after each calibration. As the sensor ages, the slope reading will decay indicating sensor aging. Useful for resolving sensor problems.
Offset = 0.0 nA	Sensor output current at a zero ppm input. This value updates after a zero-calibration has been performed. Useful for resolving sensor problems.
Q45H0 v4.01	Transmitter software version number.

Note: A display test (all segments ON) can be actuated by pressing and holding the ENTER key while viewing the model/version number on the lower line of the display.

The MEASURE screens are intended to be used as a very quick means of looking up critical values during operation or troubleshooting.

5.11 Calibration Menu [CAL]

The calibration menu contains items for frequent calibration of user parameters. There are three items in this list: Cal Sulfide, Cal Temp. and SetRange.

Cal H₂S The sulfide calibration function allows the user to adjust the transmitter span reading to match a reference solution, or to set the sensor zero point. See Part 6 - Calibration for more details.

Cal Temp The temperature calibration function allows the user to adjust the offset of the temperature response by a small factor of ± 5 °C. The temperature input is factory calibrated to very high accuracy. However, long cable lengths and junction boxes may degrade the accuracy of the temperature measurement in some extreme situations. Therefore, this feature is provided as an adjustment. See Part 6 - Calibration for more details.

SetRange This function allows the user to set the display range of the transmitter to a specific application. Once set, all output functions use this display range to establish configuration settings. Press ENTER to initiate user entry mode, and the value will flash. Use the arrow keys to modify value; available ranges include 2.000 ppm, 20.00 ppm, and 200.0 ppm. Press ENTER to store the new value. The display range does not affect the internal auto ranging scaler that, therefore, sensitivity is to specification in any user selected range.

5.12 Configuration Menu [CONFIG]

The Configuration Menu contains all of the general user settings:

- Entry Lock** This function allows the user to lock out unauthorized tampering with instrument settings. All settings may be viewed while the instrument is locked, but they cannot be modified. The Entry Lock feature is a toggle-type setting; that is, entering the correct code will lock the transmitter and entering the correct code again will unlock it. The code is preset at a fixed value. Press ENTER to initiate user entry mode and the first digit will flash. Use arrow keys to modify value. **See Page 44 for the Q45H lock/unlock code.** Press ENTER to toggle lock setting once code is correct. Incorrect codes do not change state of lock condition.
- Set Delay** The delay function sets the amount of damping on the instrument. This function allows the user to apply a first order time delay function to the sulfide measurements being made. Both the display and the output value are affected by the degree of damping. Functions such as calibration are not affected by this parameter. The calibration routines contain their own filtering and stability monitoring functions to minimize the calibration timing. Press ENTER to initiate user entry mode, and the value will flash. Use the arrow keys to modify value; range is 0.1 to 9.9 minutes. Press ENTER to store the new value.
- Contrast** This function sets the contrast level for the display. The custom display is designed with a wide temperature range, Super-Twist Nematic (STN) fluid.
- The STN display provides the highest possible contrast and widest viewing angle under all conditions. Contrast control of this type of display is generally not necessary, so contrast control is provided as a means for possible adjustment due to aging at extreme ranges. In addition, the display has an automatic temperature compensation network. Press ENTER to initiate user entry mode, and the value will flash. Use arrow keys to modify the value; range is 0 to 8 (0 being lightest). Press ENTER to update and store the new value.
- Main Units** This function allows the user to select either PPM or mg/l.

- Zero Filter** This function forces the reading to zero when reading is below the entered value. For example, if the entered value were 0.0020 the display at 0-0019 would indicate 0.000. This feature is useful in blanking out zero noise.
- Main Display** This function allows the user to change the measurement in the primary display area. The user may select between sulfide or output current. Using this function, the user may choose to put output current in the main display area and sulfide on the secondary, lower line of the display. Press ENTER to initiate user entry mode, and the entire value will flash. Use the UP arrow key to modify the desired display value. Press ENTER to store the new value.
- *Iout#2 Mode** This function sets analog output #2 for either temperature or sulfide. Press ENTER to initiate user entry mode, and the entire value will flash. Use the UP arrow key to modify the desired value; selections include: 1-ppm for temperature, or 2-PPM for sulfide. Press ENTER to store the new value.
- Temp Units** This function sets the display units for temperature measurement. Press ENTER to initiate user entry mode, and the entire value will flash. Use the UP arrow key to modify the desired display value. The choices are °F and °C. Press ENTER to store the new value.

5.13 Control Menu [CONTROL]

The Control Menu contains all of the output control user settings:

Set 0V #1
Set 2.5V #1
Set 0V #2
Set 2.5V #2

These functions set the output range for each of the two instrument outputs. The value stored for the 0V point may be higher or lower than the value stored for the 2.5V point.

The entry values are limited to values within 20.00 ppm and must be separated by at least 1% of this range. Use the LEFT arrow key to select the first digit to be modified. Then use the UP and LEFT arrow keys to select the desired numerical value. Press ENTER to store the new value.

Output #1 will always be in units of ppm, as it is fixed to track hydrogen sulfide. Output #2 will be in either units of ppm or C/F, depending on whether hydrogen sulfide or temperature is set for Out#2 in the CONFIG menu.

5.14 Diagnostics Menu [DIAG]

The diagnostics menu contains all of the user settings that are specific to the system diagnostic functions, as well as functions that aid in troubleshooting application problems.

Set Hold

The Set Hold function locks the current loop output values on the present process value and halts operation of the controller. This function can be used prior to calibration, or when removing the sensor from the process, to hold the output in a known state. Once HOLD is released, the outputs return to their normal state of following the process input. The transfer out of HOLD is bumpless on the both analog outputs - that is, the transfer occurs in a smooth manner rather than as an abrupt change. An icon on the display indicates the HOLD state, and the HOLD state is retained even if power is cycled. Press ENTER to initiate user entry mode, and entire value will flash. Use the UP arrow key to modify the desired value, selections are **ON** for engaging the HOLD function, and **OFF** to disengage the function. Press ENTER to store the new value.

The Set Hold function can also hold at an output value specified by the user. To customize the hold value, first turn the HOLD function on. Press the ESC key to go to the DIAG Menu and scroll to Sim Output using the UP arrow key. Press ENTER. Follow the instructions under Sim Output (see following page).

Fault List

The Fault List screen is a read-only screen that allows the user to display the cause of the highest priority failure. The screen indicates the number of faults present in the system and a message detailing the highest priority fault present. Note that some faults can result in multiple displayed failures due to the high number of internal tests occurring. As faults are corrected, they are immediately cleared.

Faults are not stored; therefore, they are immediately removed if power is cycled. If the problem causing the faults still exists, however, faults will be displayed again after power is re-applied and a period of time elapses during which the diagnostic system re-detects them. The exception to this rule is the calibration failure. When a calibration fails, no corrupt data is stored. Therefore, the system continues to function normally on the data that was present before the calibration was attempted.

After 30 minutes or if power to the transmitter is cycled, the failure for calibration will be cleared until calibration is attempted again. If the problem still exists, the calibration failure will re-occur. Press ENTER to initiate view of the highest priority failure. The display will automatically return to normal after a few seconds.

Sim Out

The Sim Out function allows the user to simulate the Hydrogen Sulfide level of the instrument in the user selected display range. The user enters a ppm value directly onto the screen, and the output responds as if it were actually receiving the signal from the sensor. This allows the user to check the function of attached monitoring equipment during set-up or troubleshooting. Escaping this screen returns the unit to normal operation. Press ENTER to initiate the user entry mode, and the right-most digit of the value will flash. Use arrow keys to modify desired value.

The starting display value will be the last read value of the input. The output will be under control of the SIM screen until the ESC key is pressed.

Note: If the HOLD function is engaged before the Sim Output function is engaged, the simulated output will remain the same even when the ESC key is pressed. Disengage the HOLD function to return to normal output. Also the Sim function on Out#2 will only work if Out#2 is set to PPM.

- Auto-Off** Enables the automatic shut-off feature for the instrument. If ON, the instrument will automatically shut-off in 30 minutes after no keys are pressed to save power. If OFF, the meter will stay powered continuously until either the internal power switch on the battery board is turned OFF, or the battery voltage drops to the cut-off point (approximately 8-10 days on a standard 9 VDC alkaline battery.) Press ENTER to initiate user entry mode, and the entire value will flash. Use the UP arrow key to modify the desired display value. The choices are **OFF** and **ON**. Press ENTER to store the new value
- BackLight** The Back-light screen is used to set the operating conditions under which the backlight will turn on. The default is AUTO, which configures the light to come on whenever any key is pressed. The light will automatically shut off if no key is pressed for 30 seconds. Other selections are OFF (always off), AL for Alarm, where the light comes on in alarm condition and flashes under a Fail condition, and ON (always on). Do not select ON when using internal batteries for operation, as battery life will be greatly reduced.
- Set Default** The Set Default function allows the user to return the instrument back to factory default data for all user settings or for just the calibration default. It is intended to be used as a last resort troubleshooting procedure. All user settings or the calibration settings are returned to the original factory values. Hidden factory calibration data remains unchanged. Press ENTER to initiate user entry mode and select either **CAL** or **ALL** with the UP arrow key. The default CAL routine will reset the zero offset to 0.0 nA and reset the slope to 100%. The default ALL routine will reset all program variables to factory default and should be used with care since it will change any user settings that were programmed in the field.

Part 6 – Calibration

6.1 Calibration

Once power is applied, the H₂S sensor must be given time to stabilize. This is best done by following the zeroing procedure below. Establishing a stable zero is critical to the proper operation of the monitor. A complete calibration will include zeroing and spanning the sensor.

6.2 Zero Cal

Hydrogen Sulfide sensors have fairly low offset currents at zero. In some cases, it is sufficient to simply leave the zero at the factory default of 0.0 nA. If measurements are being made that are normally above 5 PPM, leaving the unit at electronic zero is satisfactory. If the units is to be used for low level measurements on scrubber outlets, zeroing the sensor in ambient air is needed to correct for the sensor zero current, which is normally less than 0.2 PPM equivalent. An electronic zero can be set by disconnecting the sensor from the cable and performing steps 1-5 below.

The steps below assume that the sensor has been powered up for at least 8 hours prior to zeroing. It is preferable to allow the monitor to run for 24 hours prior to zeroing if possible to allow complete stabilization. If the unit has been running with the sensor connected, the sensor will normally return to a stable zero within 30 minutes.

1. Connect the sensor to the electronics by plugging the cable plug into the receptacle on the top of the sensor.
2. Remove the sensor from the holder if it is already installed in a duct adapter. Place the rubber sensor cap supplied with unit on the end of the sensor and allow it to sit for 30 minutes. If the sensor is outdoors, shade the sensor with a piece of cardboard or other material so it is not in direct sunlight.
3. Scroll to the CAL menu section using the MENU key and press ENTER or the UP arrow key. **Cal Sulfide** will then be displayed.

Press the ENTER key. The screen will display a flashing **1-Ref** for span calibration or a **2-Zer** for zero calibration. Using the UP arrow key, set for a **2-Zer** zero calibration and press ENTER.

The system now begins acquiring data for the sensor zero calibration value. As data is gathered, the units for sensor current in nanoamps (nA) may flash. Flashing units indicate that this parameter is unstable. The calibration data point acquisition will stop only when the data remains stable for a pre-determined amount of time. This can be overridden by pressing ENTER. If the data remains unstable for 10 minutes, the calibration will fail and the message **CalUnstable** will be displayed.

4. If accepted, the screen will display the message **PASS** with the new sensor zero reading (offset), then it will return to the main measurement display. If the calibration fails, a message indicating the cause of the failure will be displayed and the FAIL icon will be turned on. The range of acceptable value for sensor offset is -999 to +999 nA. Should a FAIL occur, carefully inspect the sensor for membrane fouling. Should the offset value remain high and result in calibration failures, review the Service section of this manual, and then contact the service dept. at ATI for further assistance.

The sensor zero offset value in nA from the last zero calibration is displayed on the lower line of the Default Menus for information purposes.

6.3 Span Cal

Span calibration is done using compressed gas hydrogen sulfide standards. These standards are available from ATI or from a variety of specialty gas suppliers. These are the same types of standards used to calibrate hydrogen sulfide gas leak detectors and may already be available at the plant. If so, all that is needed is the sensor calibration barb supplied with the system. If not, a calibration kit with the necessary span gas is available from ATI by ordering part number 00-0180.

To calibrate the system, follow the procedure below.

1. Remove the plug on the side of the sensor holder (see page 11 for location). Install the calibration barb in place of the plug. You do not need to tighten this fitting with a tool. Hand tight is enough for calibration purposes.
2. Connect your calibration gas source to the barb fitting using 1/8" ID tubing. Turn on the flow of span gas. ATI calibration kits provide a fixed flow of gas at 500 cc/min. If using another source of gas, simply adjust the flow of gas for a flowrate between 250 and 750 cc/min.
3. Allow span gas to flow for 5 minutes.
4. Scroll to the CAL menu section using the MENU key and press ENTER or the UP arrow key. **Cal Sulf** then is displayed.

5. Press the ENTER key. The screen will display a flashing **1-Ref** for span calibration or a **2-Zer** for zero calibration. Using the UP arrow key, set for a **1-Ref** span calibration and press ENTER.
6. The system now begins acquiring data for the calibration value. As data is gathered, the units for ppm may flash. Flashing units indicate that this parameter is unstable. The calibration data point acquisition will stop only when the data remains stable for a pre-determined amount of time. This can be overridden by pressing ENTER. If the data remains unstable for 10 minutes, the calibration will fail and the message **CalUnstable** will be displayed.
7. The screen will display the last measured ppm value and a message will be displayed prompting the user for the span gas value. The user must then modify the screen value with the arrow keys and press ENTER. The system then performs the proper checks.
8. If accepted, the screen will display the message **PASS** with the new sensor slope reading, then it will return to the main measurement display. If the calibration fails, a message indicating the cause of the failure will be displayed and the FAIL icon will be turned on. The range of acceptable values for sensor slope is 25% to 300%.

The sensor offset value in % from the last span calibration is displayed on the lower line of the Default Menus for information purposes.

6.4 Temperature Calibration

The temperature calibration sequence is essentially a 1-point offset calibration that allows adjustments of approximately ± 5 °C.

The sensor temperature may be calibrated on line, or the sensor can be removed from the process and placed into a known solution temperature reference. In any case, it is critical that the sensor be allowed to reach temperature equilibrium with the solution in order to provide the highest accuracy. When moving the sensor between widely different temperature conditions, it may be necessary to allow the sensor to stabilize as much as one hour before the calibration sequence is initiated. If the sensor is on-line, the user may want to set the output HOLD feature prior to calibration to lock out any output fluctuations.

1. Scroll to the CAL menu section using the MENU key and press ENTER or the UP arrow key.
2. Press the UP arrow key until **Cal Temp** is displayed.
3. Press the ENTER key. The message **Place sensor in solution then press ENTER** will be displayed. Move the sensor into the calibration reference (if it hasn't been moved already) and wait for temperature equilibrium to be achieved. Press ENTER to begin the calibration sequence.
4. The calibration data gathering process will begin. The message **Wait** will flash as data is accumulated and analyzed. The °C or °F symbol may flash periodically if the reading is too unstable.
5. The message **Adjust value - press ENTER** will be displayed, and the right-most digit will begin to flash, indicating that the value can be modified. Using the UP and LEFT arrow keys, modify the value to the known ref solution temperature. Adjustments up to ± 5 °C from the factory calibrated temperature are allowed. Press ENTER.

Once completed, the display will indicate **PASS** or **FAIL**. If the unit fails, the temperature adjustment may be out of range, the sensor may not have achieved complete temperature equilibrium, or there may be a problem with the temperature element. In the event of calibration failure, it is recommended to attempt the calibration again immediately.

Part 7 – System Maintenance

7.1 General

The Q45S/87 Wet Hydrogen Sulfide System will generally provide unattended operation over long periods of time. With proper care, the system should continue to provide measurements indefinitely. For reliable operation, maintenance on the system must be done on a regular schedule. Keep in mind that preventive maintenance on a regular schedule is much less troublesome than emergency maintenance that always seems to come at the wrong time.

7.2 Analyzer Maintenance

No unusual maintenance of the analyzer is required if installed according to the guidelines of this operating manual. If the enclosure door is frequently opened and closed, it would be wise to periodically inspect the enclosure sealing gasket for breaks or tears.

7.3 Sensor Maintenance

Sensor maintenance is required for accurate measurements. The primary requirement is simply to keep the sensor clean. A periodic wash with distilled water will remove particulates that might accumulate on the sensor face. If necessary, replace the prefilter on the front of the assembly. This should be done at least every 6 months.

The frequency of cleaning depends on the conditions of any given installation and are difficult to predict with certainty. Start by inspecting the sensor weekly. If no buildup occurs in a week, then move to biweekly inspection. If that proves unnecessary, then move to monthly inspection. Inspection should be done at least once a month, and calibration should be checked once a month.

Cleaning accumulated deposits should only be done with distilled water. Using a “squirt bottle” such as that used in a laboratory, simply wash the tip of the sensor with a stream of water. NEVER use detergents on this sensor or it will be destroyed. Always check the calibration of the system after cleaning and recalibrate if necessary.

After calibration, check the lower line of the MEASURE screen to see what the new slope value is. The sensor output will decrease over time as the membrane becomes fouled. This reduction indicates that the sensor is losing sensitivity to H₂S. When the slope value falls below 50%, be prepared to replace the sensor within the next few months.

Part 8 – Troubleshooting

8.1 General

The information in this section is intended to be used to quickly resolve an operational problem. During any troubleshooting process, it will save time if the operator can first determine if the problem is related to the analyzer, sensor, or some external source. Therefore, this section is organized from the approach of excluding any likely external sources, isolating the analyzer, and finally isolating the sensor. If these procedures still do not resolve the operational problems, any results the operator may have noted here will be very helpful when discussing the problem with the factory technical support group.

8.2 External Sources of Problems

To begin this process, review the connections of the system to all external connections.

1. Verify proper wiring of sensor to analyzer.
2. Verify the proper power battery voltage.
3. Check sensor membrane for fouling. Look closely for signs of grease or oil which may be present. Replace the sensor if necessary. Sensor condition can only be determined by the use of a suitable span gas.

8.3 Analyzer Tests

1. Disconnect power and completely disconnect all output wiring coming from the analyzer. Remove sensor wiring, and analog output wiring. Re-apply power to the analyzer.
2. Using the Simulate feature, check operation of analog outputs and relays with a DMM.
3. Check cell drive circuit. With a digital voltmeter (DVM), measure the voltage between the ORANGE and BLUE terminals with the BLUE jumpered to the WHITE on the monitor to verify that the millivolt value is actually 0 mV.**(REMOVE JUMPER AFTER VERIFICATION)**
4. Check TC drive circuit. Place a wire-short between the GREEN and BLACK terminals. With a digital voltmeter (DVM), measure the voltage between the BLACK and RED terminals on the monitor to verify that the TC drive circuit is producing about 4.8-5.1 Vdc open circuit. Remove DVM completely and connect a 100 Ohm resistor from the BLACK to RED terminals. The

temperature reading should display approximately 0°C and the sulfide reading should display approximately 0 ppm.

8.4 Display Messages

The Q45 Series instruments provide a number of diagnostic messages which indicate problems during normal operation and calibration. These messages appear as prompts on the secondary line of the display or as items on the Fault List.

MESSAGE	DESCRIPTION	POSSIBLE CORRECTION
Max is 200	Entry failed, maximum user value allowed is 200.	Reduce value to ≤ 200
Min is 200	Entry failed, minimum value allowed is 200.	Increase value to ≥ 200
Cal Unstable	Calibration problem, data too unstable to calibrate. Icons will not stop flashing if data is too unstable. User can bypass by pressing ENTER.	Clean sensor, get fresh cal solutions, allow temperature and conductivity readings to fully stabilize, do not handle sensor or cable during calibration.
Out of Range	Input value is outside selected range of the specific list item being configured.	Check manual for limits of the function to be configured.
Locked!	Transmitter security setting is locked.	Enter security code to allow modifications to settings.
Unlocked!	Transmitter security has just been unlocked.	Displayed just after security code has been entered.
Sensor High	The raw signal from the sensor is too high and out of instrument range.	Check wiring connections to sensor.
Sensor Low	The raw signal from the sensor is too low.	Check wiring connections to sensor.
Sulfide High	The sulfide reading is greater than the maximum of the User-selected range.	The reading is over operating limits. Set measuring range to the next highest level.
Cal Fail	Failure of sulfide calibration. FAIL icon will not extinguish until successful calibration has been performed, or 30 minutes passes with no keys being pressed.	Clean sensor redo zero and span calibration. If still failure, sensor slope may be less than 25% or greater than 300%. Perform sensor tests as described in section. Replace sensor if still failure.
EPROM Fail	Internal nonvolatile memory failure	System failure, consult factory.
Chcksum Fail	Internal software storage error.	System failure, consult factory.
Display Fail	Internal display driver fail.	System failure, consult factory.
Range Cal Fail	Failure of factory temperature calibration.	Consult factory.

Figure 9 - Q45H Display Messages

Spare Parts

<u>Part No.</u>	<u>Description</u>
03-0342-1	Q45S front lid assembly
07-0136	Battery powered monitor electronics assembly
00-1069	Hydrogen Sulfide Sensor
05-0087	Sensor prefilter membrane, package of 10
45-0214	Sensor holder
45-0215	Sensor adapter
45-0010	Prefilter end cap
42-0091	O-ring, sensor holder (rear)
42-0101	O-ring, sensor holder (front)

Lock/Unlock Code: 1456

PRODUCT WARRANTY

Analytical Technology, Inc. (Manufacturer) warrants to the Customer that if any part(s) of the Manufacturer's equipment proves to be defective in materials or workmanship within the earlier of 18 months of the date of shipment or 12 months of the date of start-up, such defective parts will be repaired or replaced free of charge. Inspection and repairs to products thought to be defective within the warranty period will be completed at the Manufacturer's facilities in Collegeville, PA. Products on which warranty repairs are required shall be shipped freight prepaid to the Manufacturer. The product(s) will be returned freight prepaid and allowed if it is determined by the manufacturer that the part(s) failed due to defective materials or workmanship.

This warranty does not cover consumable items, batteries, or wear items subject to periodic replacement including lamps and fuses.

Gas sensors carry a 12 months from date of shipment warranty and are subject to inspection for evidence of misuse, abuse, alteration, improper storage, or extended exposure to excessive gas concentrations. Should inspection indicate that sensors have failed due to any of the above, the warranty shall not apply.

The Manufacturer assumes no liability for consequential damages of any kind, and the buyer by acceptance of this equipment will assume all liability for the consequences of its use or misuse by the Customer, his employees, or others. A defect within the meaning of this warranty is any part of any piece of a Manufacturer's product which shall, when such part is capable of being renewed, repaired, or replaced, operate to condemn such piece of equipment.

This warranty is in lieu of all other warranties (including without limiting the generality of the foregoing warranties of merchantability and fitness for a particular purpose), guarantees, obligations or liabilities expressed or implied by the Manufacturer or its representatives and by statute or rule of law.

This warranty is void if the Manufacturer's product(s) has been subject to misuse or abuse, or has not been operated or stored in accordance with instructions, or if the serial number has been removed.

Analytical Technology, Inc. makes no other warranty expressed or implied except as stated above.

WATER QUALITY MONITORS

Dissolved Oxygen
Free Chlorine
Combined Chlorine
Total Chlorine
Residual Chlorine Dioxide
Potassium Permanganate
Dissolved Ozone
pH/ORP
Conductivity
Hydrogen Peroxide
Peracetic Acid
Dissolved Sulfide
Residual Sulfite
Fluoride
Dissolved Ammonia
Turbidity
Suspended Solids
Sludge Blanket Level
MetriNet Distribution Monitor

GAS DETECTION PRODUCTS

NH₃ Ammonia
CO Carbon Monoxide
H₂ Hydrogen
NO Nitric Oxide
O₂ Oxygen
CO Cl₂ Phosgene
Br₂ Bromine
Cl₂ Chlorine
ClO₂ Chlorine Dioxide
F₂ Fluorine
I₂ Iodine
H_x Acid Gases
C₂H₄O Ethylene Oxide
C₂H₆O Alcohol
O₃ Ozone
CH₄ Methane (Combustible Gas)
H₂O₂ Hydrogen Peroxide
HCl Hydrogen Chloride
HCN Hydrogen Cyanide
HF Hydrogen Fluoride
H₂S Hydrogen Sulfide
NO₂ Nitrogen Dioxide
NO_x Oxides of Nitrogen
SO₂ Sulfur Dioxide
H₂Se Hydrogen Selenide
B₂H₆ Diborane
GeH₄ Germane
AsH₃ Arsine
PH₃ Phosphine
SiH₄ Silane
HCHO Formaldehyde
C₂H₄O₃ Peracetic Acid
DMA Dimethylamine