



## O & M Manual



# UniSens 2-Wire Gas Transmitter

### Home Office

Analytical Technology, Inc.  
6 Iron Bridge Drive  
Collegeville, PA 19426  
Phone: 800-959-0299  
610-917-0991  
Fax: 610-917-0992  
Email: [sales@analyticaltechnology.com](mailto:sales@analyticaltechnology.com)  
Web: [www.Analyticaltechnology.com](http://www.Analyticaltechnology.com)

### European Office

ATI (UK) Limited  
Unit 1 & 2 Gatehead Business Park  
Delph New Road, Delph  
Saddleworth OL3 5DE  
Phone: +44 (0)1457-873-318  
Fax: + 44 (0)1457-874-468  
Email: [sales@atiuk.com](mailto:sales@atiuk.com)

## TABLE OF CONTENTS

INTRODUCTION .....	3
AUTO-TEST OPTION .....	4
DUCT MOUNTED SENSORS .....	6
SPECIFICATIONS .....	7
INSTALLATION .....	8
MECHANICAL MOUNTING .....	8
DUCT MOUNT SENSOR INSTALLATION .....	10
SENSING MODULE REMOVAL .....	11
CHANGING GAS SENSOR TYPE .....	11
ELECTRICAL CONNECTION .....	12
OPERATION .....	14
START-UP .....	14
STARTUP DELAY .....	15
FRONT PANEL MAGNETIC CONTROLS .....	15
LIQUID CRYSTAL DISPLAY .....	16
MENU SEQUENCE .....	17
TRANSMITTER MODE SELECTION .....	19
INFORMATION MODE .....	19
TEST MODE .....	19
MANUAL AUTO-TEST ACTIVATION .....	19
ANALOG OUTPUT SIMULATION .....	20
CALIBRATION .....	21
SENSING MODULE ZERO ADJUSTMENT .....	22
SENSING MODULE SPAN ADJUSTMENT .....	23
CALIBRATION OF DUCT MOUNT SENSORS .....	24
MA OUTPUT ADJUSTMENT .....	25
UNDER RANGE ENABLE/DISABLE SELECTION .....	25
AUTO-TEST ENABLE/DISABLE SELECTION .....	25
ERROR MESSAGES .....	26

## FIGURES

Figure 1 - UniSens Transmitter Components .....	5
Figure 2 - UniSens Transmitter w/Duct Sensor Components .....	6
Figure 3 - Overall Dimensions .....	8
Figure 4 - Wall Mounting Bracket .....	9
Figure 5 - Duct Mount Sensor Installation .....	10
Figure 6 - Electrical Connections .....	12
Figure 7 - Remote Electrical Connections .....	13
Figure 8 - UniSens Front Panel .....	15
Figure 9 - Liquid Crystal Display .....	16
Figure 10 - Transmitter Program Chart .....	17
Figure 11 - Sensor Calibration Adapter Assemblies .....	22
Figure 12 - Duct Mount Sensor Calibration .....	24

**INTRODUCTION**

**UniSens** is a two-wire gas transmitter for use in monitoring hazardous gases in ambient air. It is designed to monitor gas concentration in areas around storage cylinders, process piping, or gas feed equipment in virtually any type of industrial plant environment.

The name **UniSens** signifies the fact that this is a Universal Sensor System. ATI sensor modules can be interchanged on the universal transmitter to easily reconfigure for a different gas or range. Sensing modules are available for monitoring a variety of gases and ranges as shown in Table 1.

**TABLE 1**

<b>GAS</b>	<b>CODE NO.</b>	<b>STD. RANGE</b>	<b>MIN. RANGE</b>	<b>MAX. RANGE</b>
<b>GENERAL GASES</b>				
Alcohol	39	0-500 PPM	0-500 PPM	0-2000 PPM
Ammonia	15 *	0-100 PPM	0-50 PPM	0-1000 PPM
Carbon Monoxide	16 *	0-100 PPM	0-50 PPM	0-1000 PPM
Ethylene Oxide	37	0-20 PPM	0-20 PPM	0-200 PPM
Formaldehyde	38	0-20 PPM	0-20 PPM	0-200 PPM
Hydrogen	18	0-4 %	0-2000 PPM	0-10 %
Nitric Oxide	25	0-50 PPM	0-25 PPM	0-500 PPM
Oxygen	19	0-25%	0-10%	0-100%
Phosgene	20	0-2 PPM	0-2 PPM	0-200 PPM
<b>OXIDANT GASES</b>				
Bromine	10 *	0-2 PPM	0-2 PPM	0-100 PPM
Chlorine	11 *	0-10 PPM	0-2 PPM	0-100 PPM
Chlorine Dioxide	12 *	0-2 PPM	0-2 PPM	0-100 PPM
Fluorine	13 *	0-2 PPM	0-2 PPM	0-100 PPM
Hydrogen Peroxide	34	0-10 PPM	0-10 PPM	2000 PPM
Iodine	35*	0-10 PPM	0-2 PPM	0-100 PPM
Ozone	14 *	0-2 PPM	0-2 PPM	0-100 PPM
<b>ACID GASES</b>				
Hydrogen Chloride	21 *	0-20 PPM	0-10 PPM	0-200 PPM
Hydrogen Cyanide	22 *	0-20 PPM	0-10 PPM	0-200 PPM
Hydrogen Fluoride	23 *	0-20 PPM	0-10 PPM	0-200 PPM
Hydrogen Sulfide	24 *	0-50 PPM	0-10 PPM	0-500 PPM
Nitrogen Dioxide	26 *	0-20 PPM	0-5 PPM	0-200 PPM
Sulfur Dioxide	27*	0-20 PPM	0-10 PPM	0-200 PPM
General Acid Gases	36 *	0-20 PPM	0-5 PPM	0-200 PPM
<b>HYDRIDE GASES</b>				
Arsine	28	0-1000 PPB	0-1000 PPB	0-100 PPM
Diborane	29	0-1000 PPB	0-1000 PPB	0-100 PPM
Germane	30	0-1000 PPB	0-1000 PPB	0-100 PPM
Hydrogen Selenide	31	0-1000 PPB	0-1000 PPB	0-100 PPM
Phosphine	32	0-1000 PPB	0-1000 PPB	0-1000 PPM
Silane	33	0-10 PPM	0-1 PPM	0-100 PPM

\* Indicates that Auto-Test is available for standard ranges and lower.

**UniSens** transmitters, also designated Series A12, are loop-powered devices capable of operating from DC power supplies between 12 and 30 VDC. Normally, this transmitter will be powered from the 24 VDC supply from a plant wide monitoring computer, a data logger, or an alarm systems that supplies the DC voltage. The output of the transmitter is a 4-20 mA signal which is linear with respect to concentration over the range of the sensing module.

Construction of the **UniSens** transmitter is modular to allow simple installation and maintenance as shown in Figure 1 on the next page. The transmitter electronics is housed in an aluminum shell with an 11 pin relay plug on the bottom. The outer housing is an explosion-proof and weatherproof enclosure with a relay base mounted inside. The transmitter electronics module simply plugs into the relay base, and all wiring connections are made to that base. Figure 1 shows an exploded view of a complete **UniSens** transmitter with sensing module.

The sensing elements used in the **UniSens** are electrochemical sensors manufactured by ATI. These sensors are designed for use in ambient air or in ventilation ducts at temperatures of -30° to +50° C (some sensors rated to -40° C, oxygen sensors rated to -10° C) and at relative humidities between 20 and 98% RH. Use of these sensors in extremely dry air or in condensing gas streams is not recommended.

Each sensing element is incorporated into a snap-in sensing module, which also contains electronic memory that is read by the transmitter. This memory contains information on what type of gas sensor is contained in the module, the range of that particular module, and the calibration constants for the sensor. When the module is snapped into a transmitter, this data is read into the transmitter electronics and information related to the module is displayed on the LCD display on the transmitter. Because all calibration data is stored in the sensing module, these modules can be calibrated using any spare transmitter and simply snapped into any other transmitter for operation. This unique feature eliminates the need for field calibration.

## **AUTO-TEST OPTION**

**UniSens** transmitters are available with an optional feature that eliminates much of the manual response testing required for toxic gas detection systems. This feature is referred to as Auto-Test, and consists of a miniature electrochemical gas generator close coupled to the sensor. The generator produces a "puff" of gas when activated by the transmitter. The response of the sensor is monitored during this test to be sure that it is still responding to the particular gas, and the output of the transmitter is driven below 3.7 mA if the sensor does not respond. At the same time, the LCD display indicates that there was an Auto-Test failure.

The Auto-Test sensor check occurs automatically every 24 hours so that the sensor response is verified daily. In addition, the Auto-Test can be activated manually at any time using the controls on the front of the transmitter. During the Auto-Test cycle, the 4-20 mA output is held at 4 mA so that receiving devices do not alarm during the test. Because most users manually test toxic gas sensor response once a week, the Auto-Test feature can pay for itself very quickly in reduced labor cost.

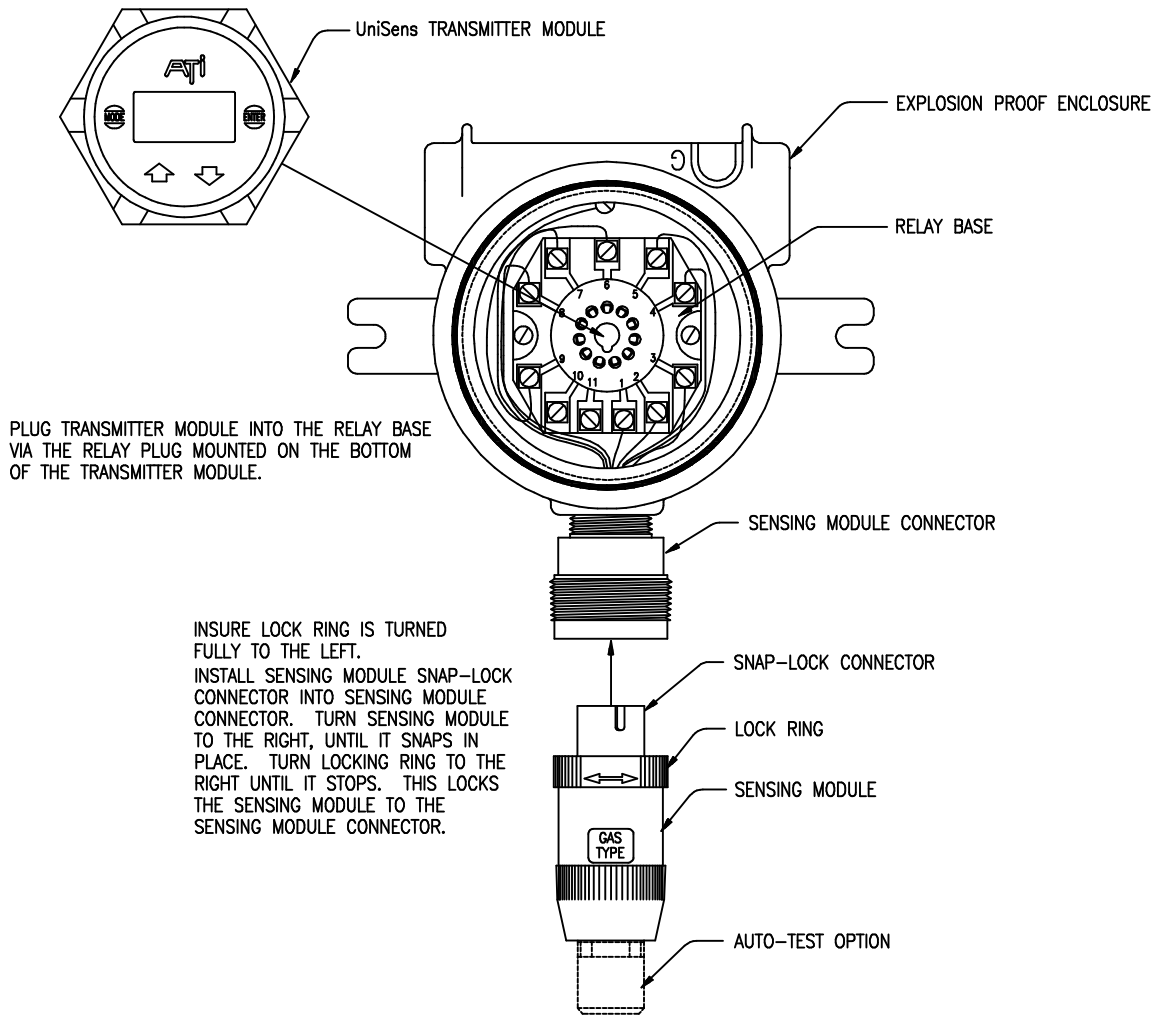
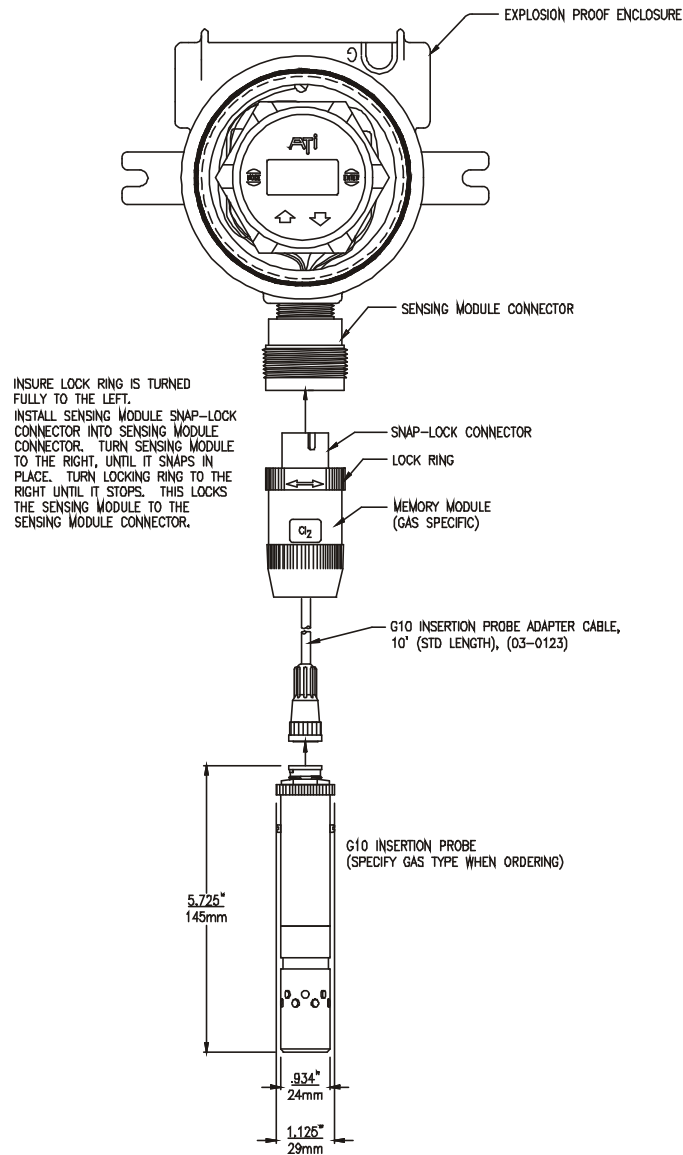

*Figure 1 - UniSens Transmitter Components*

**DUCT MOUNTED SENSORS**

A special sensor design is available as an option that allows toxic gas sensors to be inserted into a duct or pipe through a special adapter. This system is designed to allow gas monitoring in enclosed spaces with easy removal of the sensor for service. The special mounting fitting provides a method for feeding calibration gas to the sensor without complete removal from the duct.

Duct mount sensors are provided with a special interface cable so that the transmitter electronics may be mounted a short distance from the sensing location. Figure 2 below shows the components of the duct insertion version of the A12 gas transmitter.



**Figure 2 - UniSens Transmitter w/Duct Sensor Components**

## **SPECIFICATIONS**

The following general specifications refer to the **UniSens** transmitter. Because each sensing module contains a different sensor, there are specification differences for each gas.

**Gas Type:** Customer selected from available sensor list.

**Range:** Supplied with standard range for each gas unless otherwise specified.

**Display:** 4 1/2 digit LCD

**Accuracy:** Generally  $\pm 5\%$  of value, but limited by available calibration gas accuracy.

**Electronic Repeatability:**  $\pm 1\%$

**Electronic Linearity:**  $\pm 0.5\%$

**Zero Drift:** Sensor dependent, but generally less than 1% of full scale per month, non-cumulative.

**Span Drift:** Application dependent, but generally less than 3% per month.

**Under Range Trip:** -20% (when enabled)

**Output:** Loop-powered 4-20 mA, 750 ohms maximum at 24 VDC loop power

**Power:** 12-30 VDC

**Enclosure:** NEMA 4X and Explosion-proof cast aluminum, Class 1, Div. 1, Groups B, C, & D.

**Controls:** Magnetic links activated externally through glass window. Non-intrusive calibration.

**Operating Temperature:**  $-30^{\circ}$  to  $+55^{\circ}$  C (except oxygen, which is  $-10^{\circ}$  to  $+55^{\circ}$  C)

**Sensor:** Modular plug-in unit with calibration data, gas type, and range in sensor memory.

**Optional Sensor:** Duct insertion sensor with 5 foot interface cable.

**Sensor Pressure Limits:** 7-30 PSIA (0.5-2 Bar)

**Weight:** 4 lbs. (1.8 Kg.)

**Approvals:** CSA Certificate #LR 101166 (Not valid for duct mount sensor)  
Intrinsically safe when used with an approved I.S. barrier.  
Explosion-proof; Class I, Groups B, C, & D; Class II, Groups E & F, Class III without barrier

## INSTALLATION

Installation of a **UniSens** transmitter requires mechanically mounting the enclosure, grounding the enclosure, and connecting DC power to the system.

### MECHANICAL MOUNTING

Figure 3 shows the dimensions of the transmitter enclosure and the location and size of the electrical conduit connection. When used in a classified area, an explosion-proof seal should be installed as required by the local electrical code. The conduit or cable gland entry into the enclosure must be sealed with Dow Corning 732 multipurpose sealant. The sealant should be liberally applied to the 3/4-14 NPT thread on the entry nipple or cable gland before installation. If conduit is used, it must also be sealed internally at the entry point to the housing. This is required to prevent water condensation inside the conduit from draining into the enclosure.

**- WARNING - Failure to seal the conduit entry or cable gland will result in water entering the enclosure causing damage or failure to the transmitter electronics.**

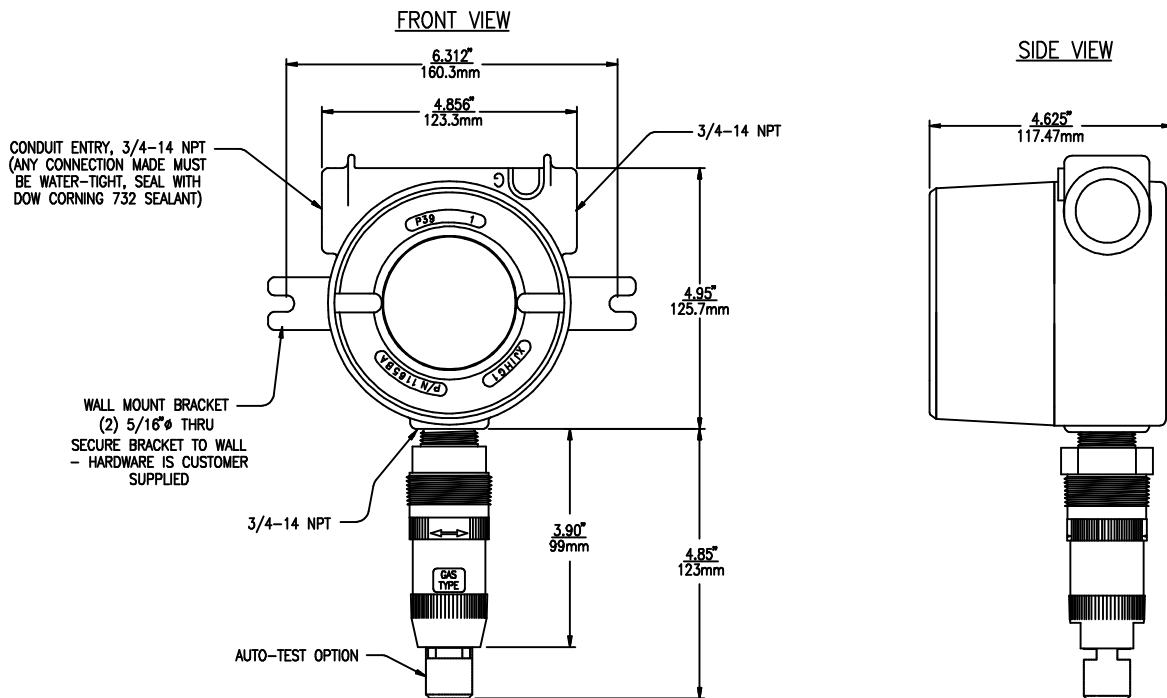

Figure 3 - Overall Dimensions



The transmitter enclosure can be mechanically supported by the conduit if proper conduit fasteners are used. A mounting bracket is supplied with the transmitter for fastening the transmitter enclosure to a wall or mounting plate. Figure 4 shows the hole center dimension for that mounting bracket. The mounting bracket attaches to the back of the enclosure with 4 screws supplied with the bracket.

BACK VIEW

WALL MOUNT BRACKET KIT P/N: 05-0017

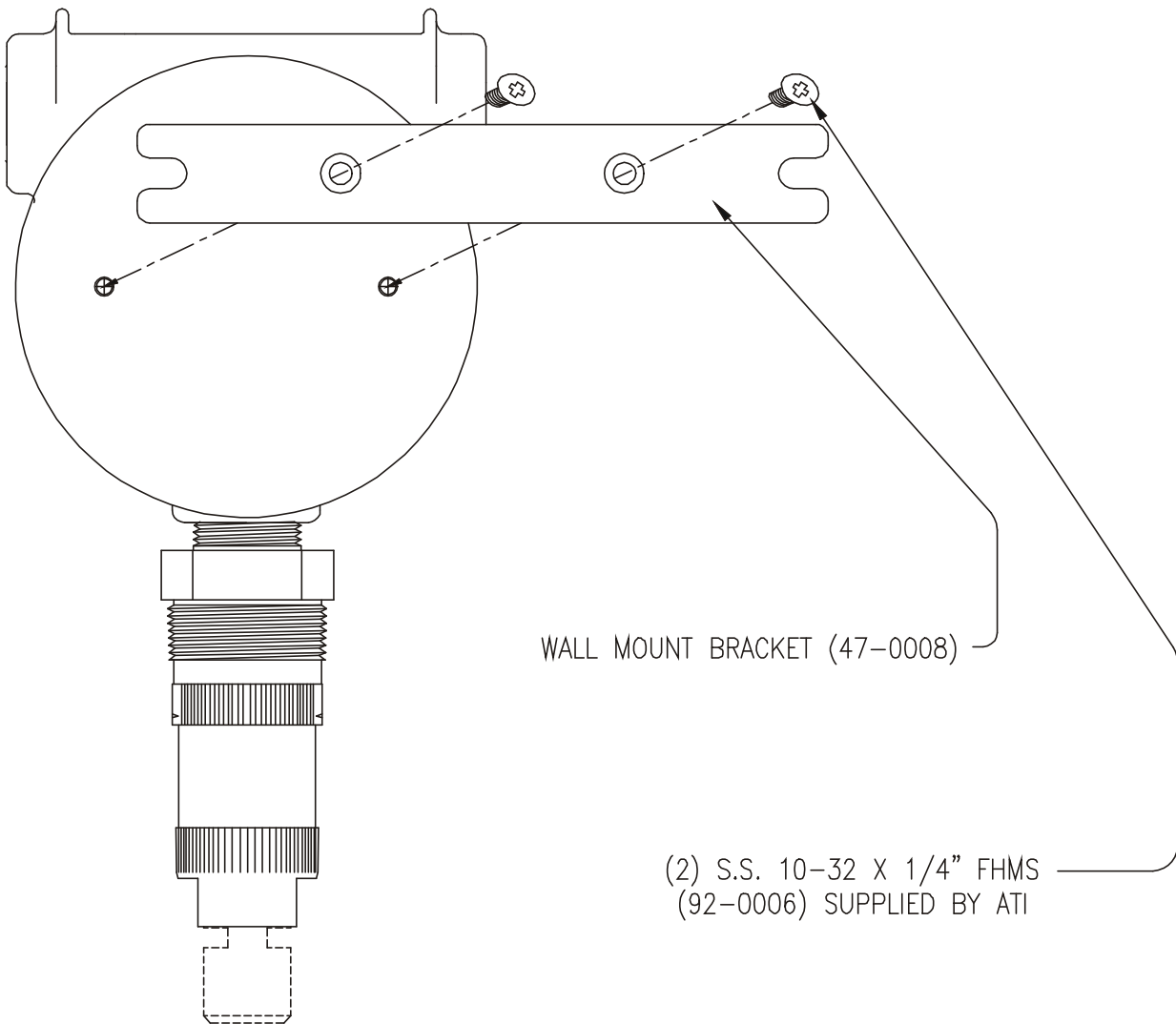
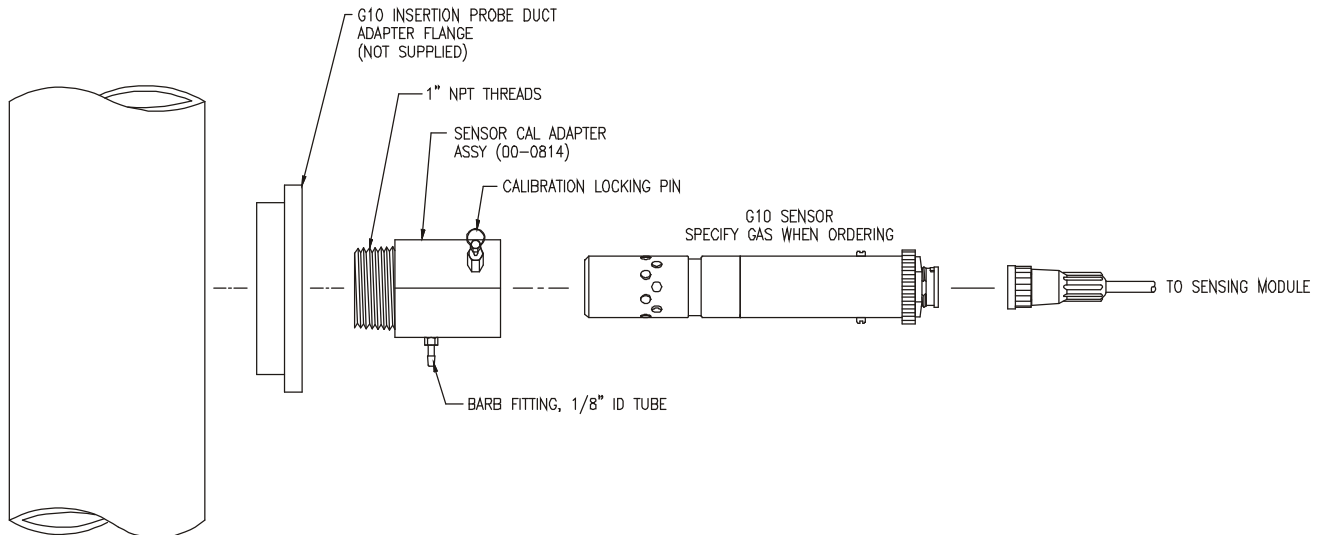

**Figure 4 - Wall Mounting Bracket**

## **DUCT MOUNT SENSOR INSTALLATION**

Duct mounted sensors are designed to be inserted into an air duct or pipe through a special adapter fitting (part number 00-0814). This fitting has a 1" MNPT thread on the front for adapting to the duct or pipe. The actual duct adapter is customer supplied.

Installation of this sensor requires that the 00-0814 adapter be screwed into the customer supplied adapter as shown in Figure 5 below. Screw in the adapter so that the calibration gas inlet port is oriented in a direction that gas tubing can easily be connected. Once the adapter is in place, the sensor will slide into the adapter easily. However, it is recommended that the sensor not be installed in the fitting until you are ready to start up the transmitter. This is especially true during construction when dust and dirt may be blowing through the duct system. Fouling of the sensor may result.



***Figure 5 - Duct Mount Sensor Installation***

## **SENSING MODULE REMOVAL**

*UniSens* sensor modules are easily inserted and removed from transmitters to allow bench calibration and simplify field service. To remove the sensor module from the transmitter, be sure that the lock ring is turned fully to the left. From the locked position, the lock ring will turn 1/2 turn. Do not attempt to remove the sensor module with the lock ring in the locked position.

After unlocking the lock ring, grab the black portion of sensor module between your thumb and forefinger and turn the entire module to the left 1/8th turn. Pull the module straight down and it will disengage from the module holder.

To install a sensor module, reverse the procedure described above. Be sure that the lock ring is in the unlocked position prior to attempting module installation. With the lock ring in the locked position, the sensor module will not snap into proper position and the transmitter will indicate a series of bars across the LCD display, indicating that there is no sensor module installed.

**NOTE: When a sensing module is unplugged from an operating transmitter, the output of the transmitter will drop below 3.2 mA, which indicates a trouble condition. However, there is a 30 second time delay on this trouble indication. When a sensing module is removed, the LCD display will begin counting down from 30. During the countdown, the output will be held it's value prior to unplugging the module. When the display reaches zero, the output will fall to the trouble condition value below 3.2 mA. This delay allows inspection or substitution of modules without affecting receiving instruments.**

## **CHANGING GAS SENSOR TYPE**

*UniSens* transmitters will accept sensor modules for all of the gases listed on page 3. Note that each gas has a specific code number. The transmitter stores the code number for any sensor module removed from it. If you plug in a sensor module that contains a different gas code number than the one removed, the transmitter will not load any data. Instead, it will wait for confirmation from the operator that a change in gas type is desired. The display will indicate "CXX" with the XX indicating the code number of the new gas sensor plugged into it. For instance, if you remove a chlorine sensor, code 11, and then plug in an HCl sensor, the display will indicate "C21", which indicates it is waiting for confirmation that you want to change the transmitter function from chlorine to hydrogen chloride. Activate the ENTER switch with the magnetic screwdriver and the HCl sensor module data will load.

**Note: Sensors can take up to 12 hours to stabilize (bias) when placed into service unless the sensor was stored in the sensor keeper.**

## **ELECTRICAL CONNECTION**

Standard transmitters are supplied with the sensing module connector factory wired to the relay base. The only connections required for installation are the two loop connections and earth ground to the enclosure. Figure 6 shows the proper terminals for loop wiring and the earth ground connection point. The transmitter module can be removed from the outer enclosure by gently rocking it back and forth while pulling out.

Sensing module holders are available with up to 5 feet of cable for remoting the sensor from the transmitter. When supplied in this configuration, electrical installation will also require connection of sensing module holders to the relay base. An 8 conductor cable connects the holder to the base, and Figure 6 provides the wiring diagram for connection of the holder to the relay base.

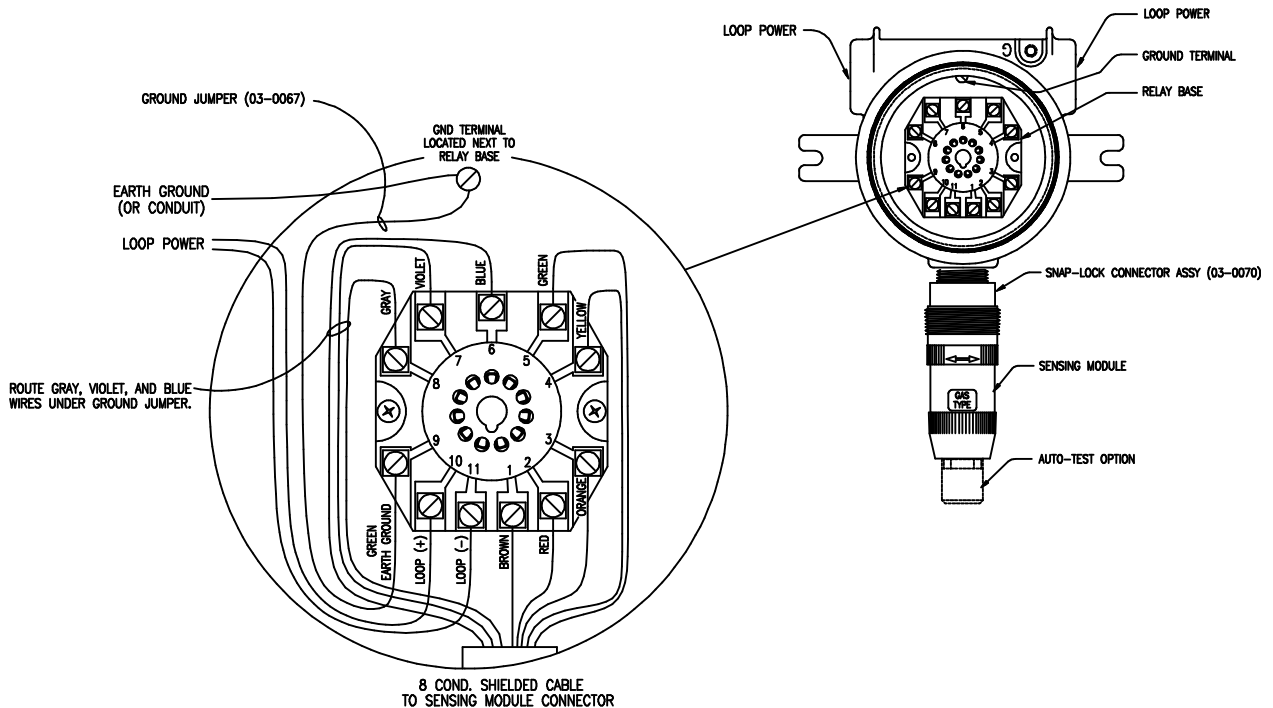

**Figure 6 - Electrical Connections**

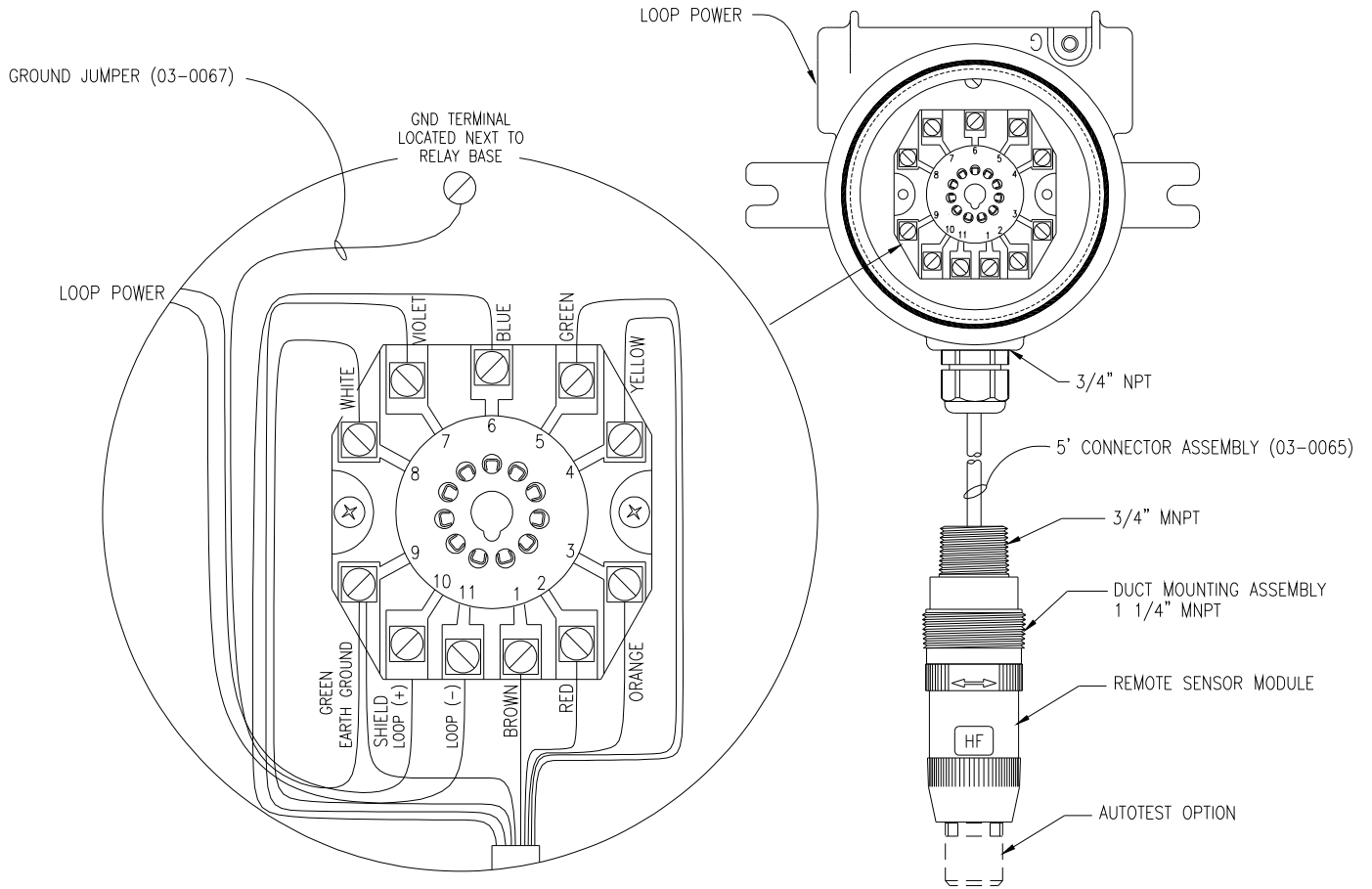

**Figure 7 - Remote Electrical Connections**

## **OPERATION**

After mechanical and electrical installation is complete, the transmitter is ready for operation. Prior to start-up, recheck the loop wiring connection to be sure it's correct. Reversing the loop wiring will not damage the transmitter, but other devices in the loop may be adversely affected.

### **START-UP**

When power is first applied, the transmitter will go through a start-up sequence. The LCD display will indicate the following information.

Load	Indicates that sensor module data is loading into the transmitter
tr 1.0	Indicates transmitter program version number
Sr 1.0	Indicates sensing module revision level
XX	Two digit gas code number (see table 1)
XXXX	PPM Number indicating the full scale range of the sensing module
Ur E / Ur d	Ur E – Indicates that the signal trouble on under range function is enabled Ur d – Indicates that the signal trouble on under range function is disabled
InSt/nonE	InSt - Indicates that Auto-Test function is installed in sensor module nonE - Indicates that sensor module does not contain an Auto-Test generator
Enab/disA	Enab - Indicates that the Auto-Test function is enabled. disA - Indicates that the Auto-Test function is disabled.
XX.XH	Number of hours until the next scheduled Auto-Test (in hours)
XXXX	Number of successful sensor tests using the Auto-Test generator
XXXX	Number of unsuccessful sensor tests using the Auto-Test generator
All Segments	Display test which powers up all display segments and flags

## **STARTUP DELAY**

When the start-up sequence is complete, the display will begin to indicate gas concentration and will display the mA lock flag, indicating that a start-up delay is in progress and that the mA output is locked at 4.0 mA (except for oxygen transmitters, where the loop will be locked at 17.4 mA, the equivalent of 20% O<sub>2</sub>). The delay period is 5 minutes, which provides time for the sensor to stabilize near zero before the output is released. After 5 minutes, the lock flag will disappear and the output will begin to track the gas concentration.

**NOTE:** For new installations where the sensor has been unpowered for an extended period, the 5 minute start-up delay may not be sufficient for the sensor to completely zero. Some sensors can take up to 30 minutes to completely stabilize when unpowered for an extended period of time.

## **FRONT PANEL MAGNETIC CONTROLS**

The front of the transmitter module contains 4 magnetically activated controls. As shown in Figure 7, these controls are MODE, ENTER, UP, and DOWN. A screwdriver with a suitable magnet is supplied with each transmitter. This magnet allows for operation of the transmitter controls without removing the cover of the outer enclosure. Magnetic controls are used for displaying information about the operation of the transmitter, and performing zero and calibration functions. These controls also allow manual activation of the Auto-Test function if installed, and simulating the 4-20 mA output at 4 different values for full loop verification.

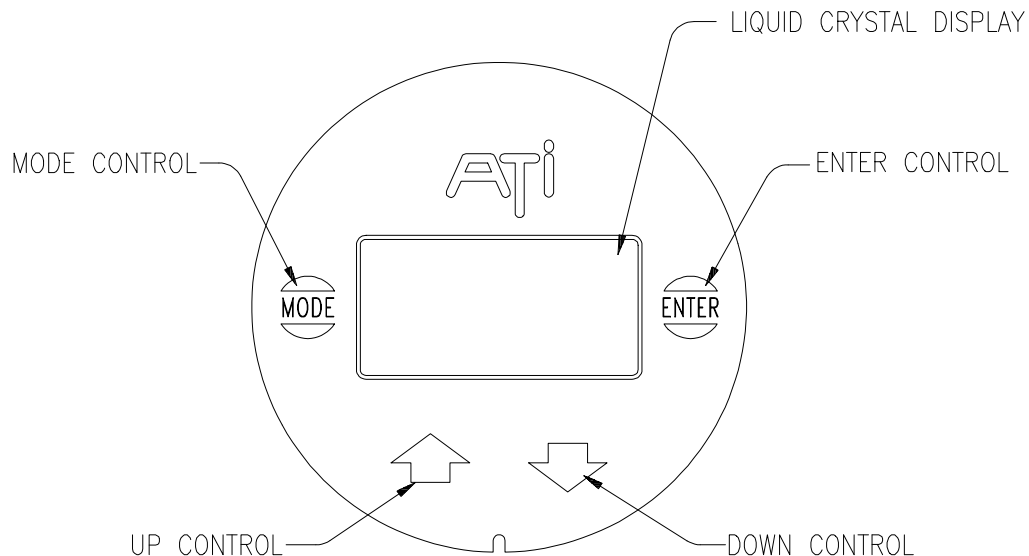

**Figure 8 - UniSens Front Panel**

## **LIQUID CRYSTAL DISPLAY**

The display in the A12 transmitter provides the operator with a real time concentration display and a variety of prompts for selecting transmitter operating modes. Figure 8 shows the display, including all of the special indicators contained in it. Below that Figure is a description of each of the indicators.

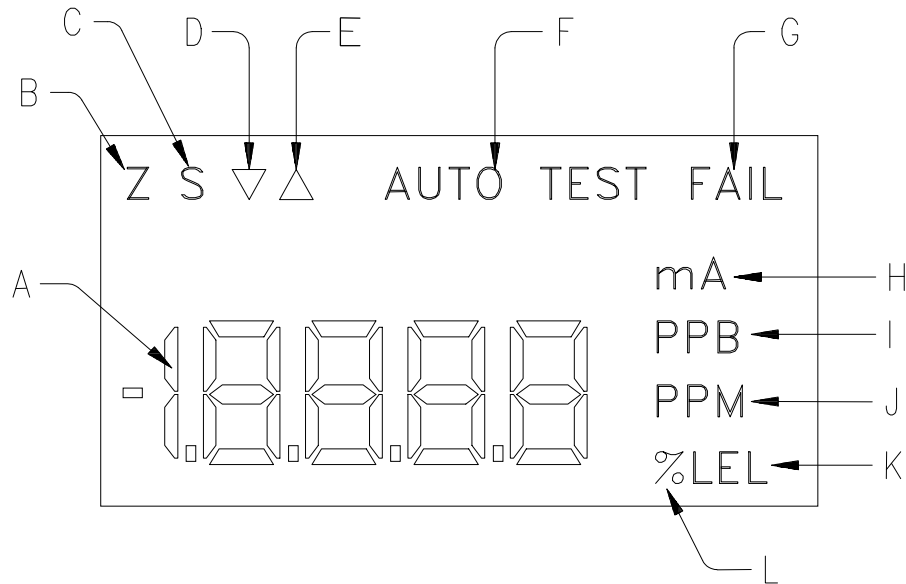

*Figure 9 - Liquid Crystal Display*

- A - Digital Concentration Display
- B - Zero Indicator, activated while zeroing a sensor module or adjusting the 4 mA output value.
- C - Span Indicator, activated while spanning a sensor module or adjusting the 20 mA output value.
- D - Down Key Indicator, activated when the magnetic control marked "∇" is activated.
- E - Up Key Indicator, activated when the magnetic control marked "Δ" is activated.
- F - Auto-Test Indicator, activated when the transmitter is running the Auto-Test routine.
- G - Fail Indicator, activated when an Auto-Test failure occurs.
- H - mA Indicator, activated during output simulation mode or when the output is locked.
- I - PPB Indicator, activated when a sensor module with a Part-Per-Billion range is installed
- J - PPM Indicator, activated when a sensor module with a Part-Per-Million range is installed
- K - LEL Indicator, activated when a sensor module with a Percent Lower Explosive Limit range is installed
- L - % Indicator, activated when a sensor module with a Percent (or % LEL) range is installed



## MENU SEQUENCE

Operation of the transmitter is accomplished from the front panel using magnetic controls, with the LCD providing visual indication of menu selections. Through menu selections, the user can review information about the transmitter, calibrate the transmitter, manually activate the Auto-Test function (if installed), simulate 4 different mA output values, and reset the transmitter to normal operation in the event of an Auto-Test failure. Figure 9 provides a block diagram of the program in the **UniSens** transmitter.

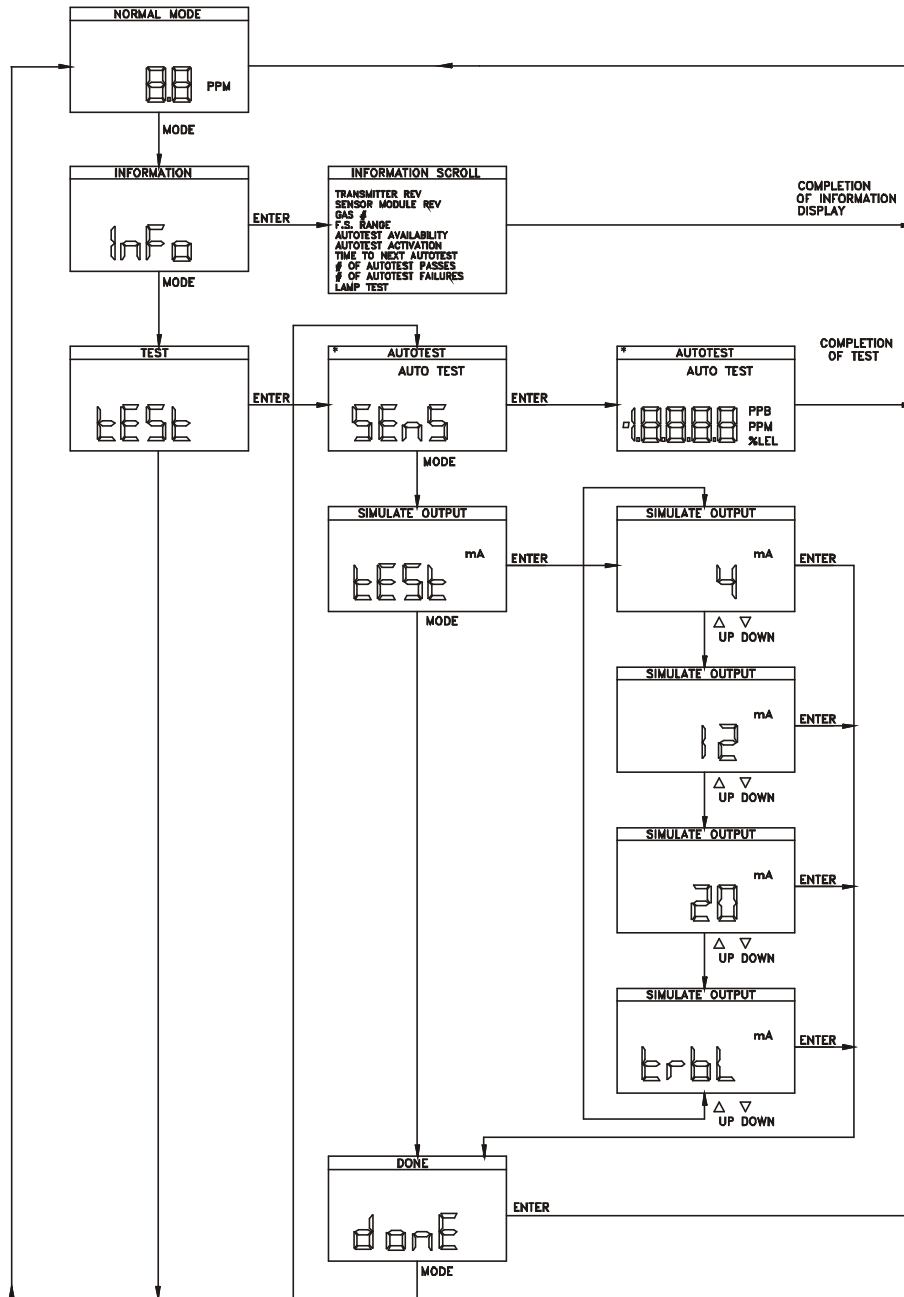
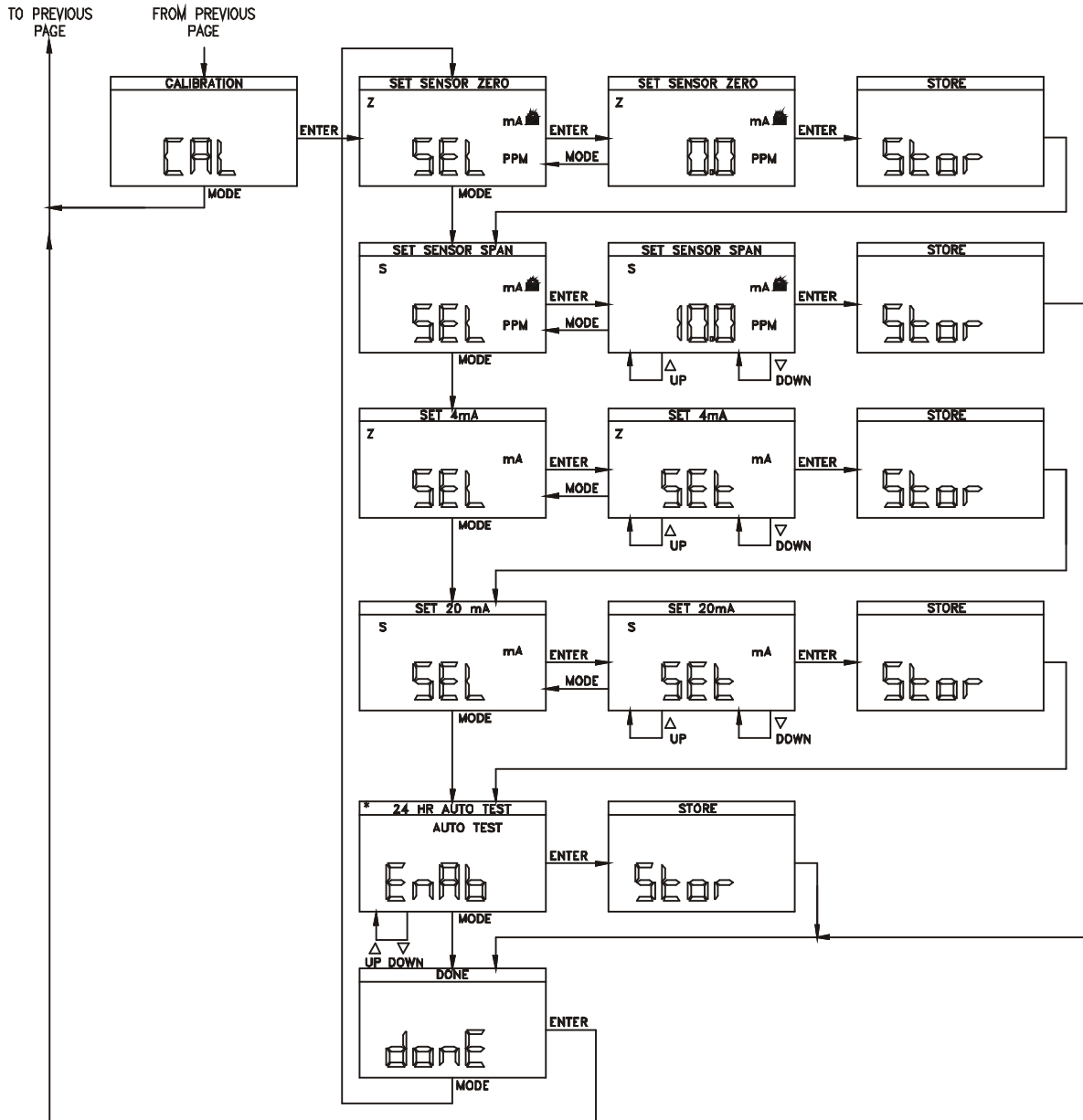

Figure 10 - Transmitter Program Chart



\* ONLY APPEARS IF  
SENSOR MODULE HAS  
AUTOTEST OPTION  
INSTALLED,

## **TRANSMITTER MODE SELECTION**

The transmitter provides 4 main mode selections. After the display scrolls through the power-up sequence and completes the start-up delay, it enters the NORMAL mode of operation, displaying gas concentration. By holding a magnet over the MODE control, the display will indicate "InFo". Repeating this process will change the display to "tESt" and then "CAL". The meaning of these modes is as follows:

- InFo Designates INFORMATION mode. In this mode, you may review the information initially displayed during the power-on sequence.
  
- tESt Designates TEST mode. In this mode, the Auto-Test generator may be manually activated, and the 4-20 mA output may be tested at 4 set values.
  
- CAL Designates CALIBRATION mode. In this mode, the zero and span of the sensing module may be adjusted, the 4 and 20 mA output current can be adjusted, and the Auto-Test generator can be enabled or disabled.

## **INFORMATION MODE**

To review the transmitter information, activate the MODE control until the display shows "InFo" and then activate the ENTER control. The display will scroll through the same information shown during power-up. See page 10 for details on the information displays.

## **TEST MODE**

There are two selections available under the TEST menu. The first selection allows manual activation of the Auto-Test by the operator. The second selection allows the transmitter output to be set to 4, 12, and 20 mA in order to check the devices tied to the output. In addition, a failure condition can be simulated, causing the output to go to about 3.6 mA.

## **MANUAL AUTO-TEST ACTIVATION**

From the NORMAL display, activate the MODE control twice and the display will read "tESt". Activate the ENTER control. If a sensing module with Auto-Test generator is installed, the display will change to "SEnS" and the AUTO TEST flag will be displayed near the top of the display. If you activate the ENTER control at this point, the Auto-TEST sequence will begin and the AUTO TEST flag will begin to flash. Activating the MODE control will allow you to escape from this routine without activating the test sequence.

When the test sequence is activated, the 4-20 mA output will be locked at the value being transmitted before the sequence began, normally close to 4.0 mA. If you observe the LCD, you will see the gas concentration begin to increase as gas is evolved from the generator. When the display reaches 10% above the start value, a PASS message will flash on the display, indicating that the sensor passed the test. At this point the AUTO TEST flag will stop flashing and go to steady on. This indicates that the Auto-Test was successful but that the 4-20 mA output is still locked. The output will stay locked for the next 2 minutes to allow the sensor to recover to zero. In addition, it will remain partially locked for an additional 8 minutes to insure complete sensor recovery before again activating the output. However, if the measured gas concentration goes above 50% of range during the second 8 minute inhibit period, the output lock is released and any receivers connected to the transmitter will indicate high gas levels.

## **ANALOG OUTPUT SIMULATION**

The *UniSens* transmitter provides the ability to simulate 4 different current output values in order to verify complete loop integrity and to calibrate receiving devices. The output may be set to values of 4.0, 12.0, and 20.0, and may also be set to the "Trouble" value below 3.7 mA.

From the NORMAL display, activate the MODE control twice and the display will read "tESt". Activate the ENTER control. If a sensing module with Auto-Test generator is installed, the display will change to "SEnS" and the TEST flag will be displayed near the top of the display. Activate the MODE control once and the display will change to tESt and the mA flag will be on. Activate the ENTER control once and the display will indicate 4 mA. The current output from the transmitter will now be locked on 4 mA. Use the UP or DOWN control to change the output to 12 mA, 20 mA, or "trbl" as desired. When "trbl" is displayed, the output will go below 3.7 mA, which is the output value used to indicate "Trouble" with the transmitter. The output current from the transmitter will change to the value shown on the display.

**CAUTION:** Simulation of 12 or 20 mA outputs may cause receiving devices to activate alarms and/or control devices. Never simulate these outputs without inhibiting alarm receivers or notifying operating personnel that a system test is in progress.

To escape the output simulation mode, activate the ENTER control once.

## **CALIBRATION**

**UniSens** transmitters should be calibrated every 3-6 months. However, the concept of calibration is a little different with this product. Because calibration constants are stored in the sensing module, you are really calibrating the sensing module rather than the transmitter itself.

The frequency of calibration is dependent on the operating environment (sensors exposed to dirt, oil mist, or vapors need more frequent calibration) and the degree to which accuracy is important. Generally, more frequent calibration is done if the gas transmitter is located where personnel are working regularly.

Sensing module calibration requires adjustment of both sensor zero and span. Sensor zero is adjusted when the sensor is exposed to zero air. Adjusting the span requires a source of span gas with a known concentration of the particular gas. Calibration kits, containing both zero air and span gas, are available from ATI for many toxic gases. Contact ATI or your local ATI representative if you have any questions on calibration gas sources.

Calibration span gas for some gases, such as HCl, Ozone, or Hydrides, are either very expensive or not available at all. Calibration of these sensors require specialized equipment, and it may be more convenient and economical to use ATI's calibration services for this function. The unique design of the sensing module allows this to be done easily. Because calibration constants are stored in memory in the sensing module, the complete module can be sent to ATI for adjustment when needed. During factory calibration, new calibration constants will be stored in the sensing module. When this module is snapped into the original transmitter, these new constants will be read into the transmitter memory, automatically adjusting the transmitter for that sensing module. Contact ATI at 800-959-0299 for details on factory calibration services.

**NOTE:** The output of the A12 transmitter is locked at 4 mA when in the calibration mode, except for oxygen transmitters, which are locked at 17.4 mA. This means that the 4-20 mA output will not change when span gas is applied. Only the LCD display will indicate changing gas concentrations. To verify output operation using span gas, apply gas while the transmitter is in the NORMAL mode of operation after calibration is complete.

## **SENSING MODULE ZERO ADJUSTMENT**

As previously mentioned, adjusting the sensing module zero requires that the sensor be exposed to air that is free of the target gas or any other gases that might cause either negative or positive interference to that sensor. Refer to the section of this manual related to the specific gas type for information on potential interferences.

If the area in which the sensor is operating is known to be gas free, then the sensing module can be zeroed without further equipment. If not, use of "zero air" from a gas cylinder is recommended. Zero air is available as part of all ATI calibration kits, or may be obtained from any specialty gas supplier. When zero air is to be used, a calibration adapter (part no. 00-0248) must be used. The calibration adapter provides a confined space around the sensor into which the zero air can flow. There are two calibration adapters available for A12 sensor modules. For D10 modules without Auto-Test, the adapter slips inside the splash guard for the sensor module. For D28 modules with Auto-Test generator, the adapter slides on to the generator.

**Note:** The gas inlet port (1/8" barb fitting) on the adapter used for the D28 module must be unscrewed partially to allow the adapter to slide over the generator. When in place, screw the fitting in so that it is retained in the slot between the generator and sensor.

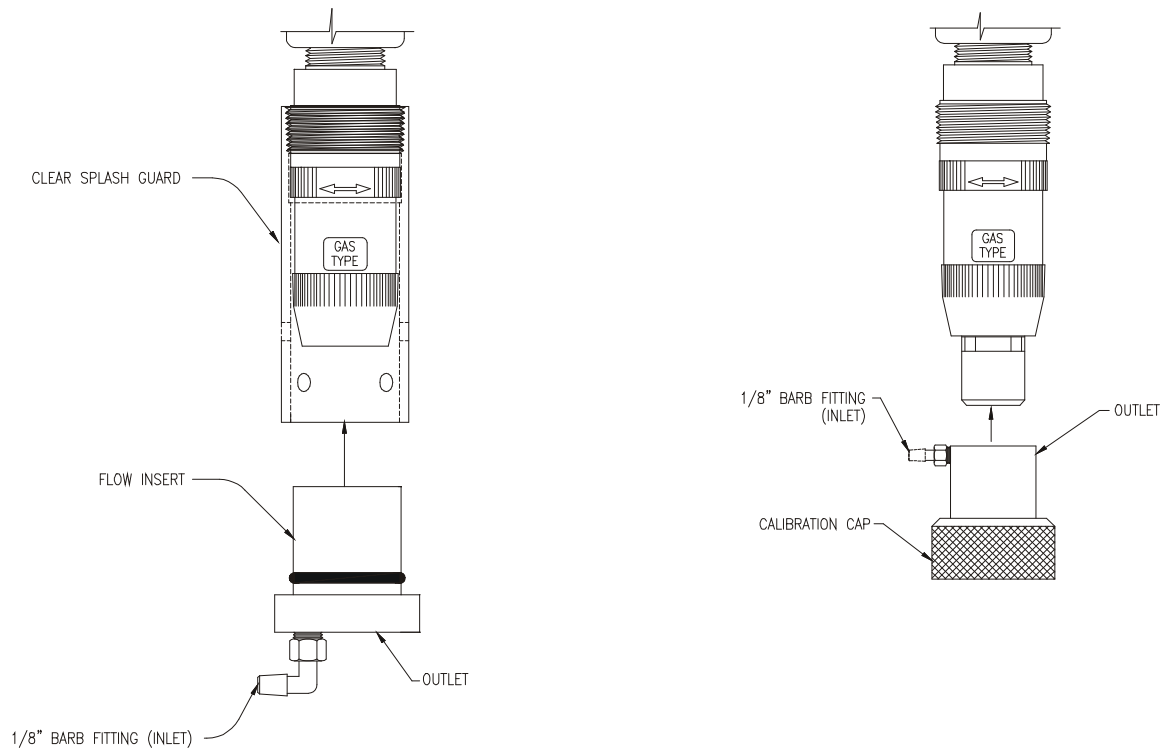

***Figure 11 - Sensor Calibration Adapter Assemblies***

To zero the transmitter, allow zero air to flow to the sensor for 5 minutes. If the sensor is located in air known to be gas free, follow the steps below to adjust the zero.

- Step 1 With the LCD indicating normal mode of operation, activate the MODE control repeatedly until the display shows "CAL". Then activate the ENTER control. The display will change to "SEL" and the "Z" (for Zero) flag on the display will light.
- Step 2 Activate ENTER again and the display will change to an indication of the current gas concentration. The value should be close to zero. Observe the display to be sure it is not either increasing or decreasing.
- Step 3 When the display value is stable, activate ENTER again and any small sensor offset will be stored in memory. The display will change to "SEL" and the "S" (for Span) flag will light. If you wish to span the sensing module, activate ENTER and proceed to the next section of this manual. If you only wish to set the zero, activate MODE until the display indicates "donE". Activate ENTER to return to the normal operating mode.

## **SENSING MODULE SPAN ADJUSTMENT**

Adjusting the sensing module span requires a source of reliable span gas. If possible, a span gas with a gas concentration of at least 25% of the full scale sensing module span is recommended. For example, if the full scale span is 20 PPM, span gas of at least 5 PPM should be used. Many span gases are available in convenient disposable cylinders, while other gases require a permeation system to generate a reliable standard. **DO NOT ATTEMPT TO ADJUST THE SPAN OF A SENSING MODULE WITHOUT A RELIABLE SPAN GAS.**

To adjust the sensing module span, proceed as follows:

- Step 1 Advance through the transmitter program using the MODE and ENTER controls until the display indicates "SEL" and the "S" flag is lit. This display is indicating that you can now select the span mode.
- Step 2 Activate ENTER and the display will indicate gas concentration. The "S" flag will remain lit.
- Step 3 Screw a calibration adapter onto the sensing module as shown in Figure 8. Connect your span gas source to the inlet fitting on the cal. adapter.
- Step 4 Turn on the flow of calibration gas and allow it to flow for 5 minutes. The LCD display should increase in response to the sensor being exposed to the target gas. After 5 minutes, use either the UP or DOWN controls to adjust the value on the display to the span gas value.
- Step 5 Activate ENTER and the new span constant will be stored in the sensing module. The display will now indicate "donE". Activate ENTER to return to normal operation.

## **CALIBRATION OF DUCT MOUNT SENSORS**

The procedure for zeroing and calibration of duct mounted gas sensors is similar to that described on pages 22 and 23 except that the calibration is done with the sensor still mounted inside the mounting adapter fitting. This fitting contains a calibration gas connection on the side. See figure 11 below for the sensor orientation when in the calibrate position.

To zero and calibrate the duct sensor, pull the sensor out of the duct until the retaining pin clicks into the retaining slot. If you pull the sensor back slowly, the retaining pin will drop into place and automatically locate the sensor in the proper position opposite the gas inlet port. Connect your zero or span gas to the gas connection port and follow the zero and span adjustment procedures from the previous 2 pages.

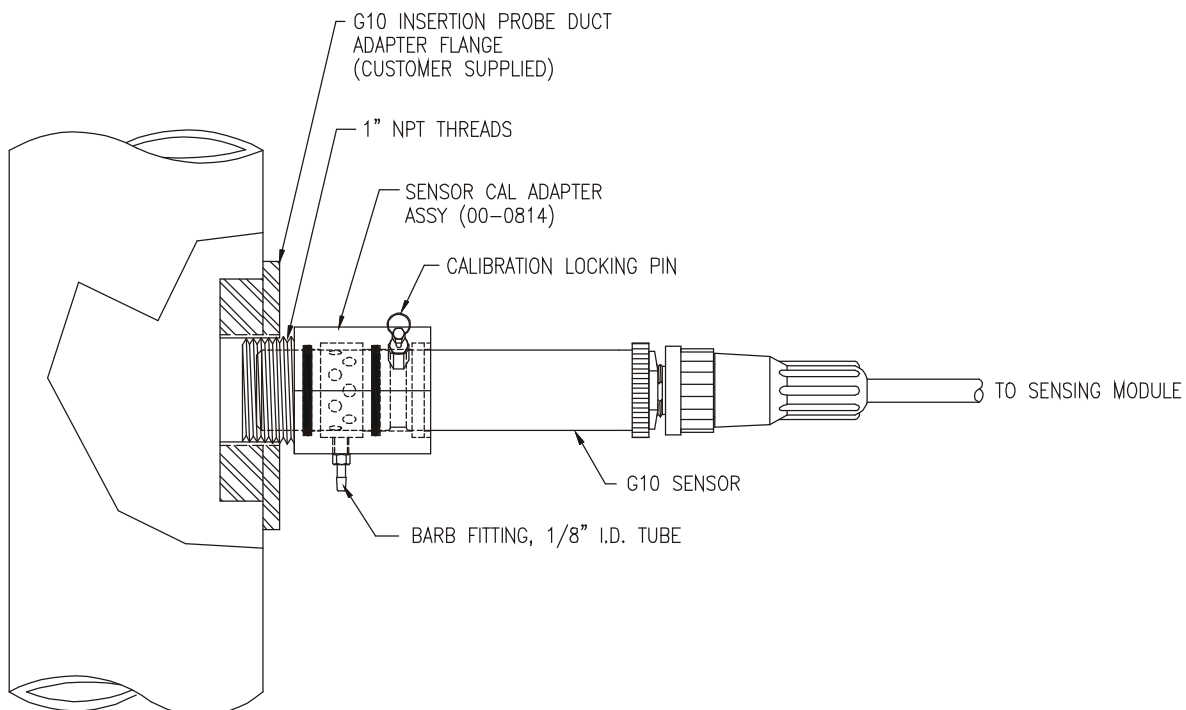

**Figure 12 - Duct Mount Sensor Calibration**



## **MA OUTPUT ADJUSTMENT**

Series A12 transmitters provide a method of adjusting (or offsetting) the 4 and 20 mA output values slightly in order to insure that other devices in the output loop read the correct value. In effect, these adjustments are the equivalent of fine zero and fine span controls.

Adjustment of the 4 and 20 mA values is done through the CAL mode. From the NORMAL display, activate MODE until the display reads "CAL". Activate ENTER once and then MODE twice so that the display reads "SEL" with the Z and mA indicators on. Activate ENTER and the display will change to "SET", with the Z and mA indicators still on. Use the UP or DOWN controls to move the 4 mA value up or down as required. The display will not indicate the output value. This must be read using a mA meter or by observing another display tied to the transmitter output.

When adjustment is complete, activate the ENTER control and the display will change to "SEL" with the S and mA indicators on. Activate ENTER and repeat the above process to adjust the 20 mA value as required. When adjustment is finished, activate ENTER to store the value and ENTER again when the display indicates "donE". This will take you back to the NORMAL display and mode of operation.

## **UNDER RANGE ENABLE/DISABLE SELECTION**

The trouble on Under range function can be enabled or disabled from the software menu. Normally, this function will be enabled so that sensor under range conditions greater than – 20% full scale will cause the transmitter to output the trouble value of 3mA.

To disable this function, start from the normal display and activate the MODE control three times to display "CAL". Activate ENTER once and then the MODE control four times. The display should now indicate "Ur E". Use the UP or DOWN control to toggle to "Ur d". The under range function is now disabled. Activate the MODE control twice to display "done". Use ENTER to return to the Normal display.

## **AUTO-TEST ENABLE/DISABLE SELECTION**

The Auto-Test function on a series A12 transmitters can be activated (enabled) or deactivated (disabled) from the software menu. Normally, this function will be enabled at all times so that the sensor response is verified regularly. However, should a problem arise with the generator, the Auto-Test function can be disabled while a new module or generator is obtained. If the sensor is still functional, disabling the Auto-Test allows the transmitter to continue normal operation without attempting its normal 24 hour test sequence.

If the transmitter was shipped with a sensor module containing an Auto-Test generator, the Auto-Test function will be enabled at the factory. To disable this function, start from the NORMAL display and activate the MODE control three times to display "CAL". Activate ENTER once and then the MODE control 4 times. The display should now indicate "EnAb". Use the UP or DOWN control to toggle to "dISA". Activate the ENTER control to store the disable value. When the display indicates "donE", use ENTER to return to the NORMAL display.

## **ERROR MESSAGES**

The A12 constantly evaluates the condition of the sensor and the output loop to detect errors that might compromise the performance of the instrument. The following messages will appear on the LCD display if the transmitter detects certain failures.

**AUTO TEST FAIL** : This message is displayed if the transmitter is equipped with the Auto-Test option and the sensor fails to respond to 3 successive tests at one hour increments. Unusual environmental conditions can cause an occasional test failure, so the system will retest the sensor an hour later if a failure occurs. After 3 failures, the AUTO TEST FAIL message appears and the output goes to 3 mA. If this occurs, test the sensor with calibration gas to determine if the failure is due to the sensor or the gas generator. Sensor or generator replacement will most likely be needed. Should the Auto-Test failure message appear due to a generator failure, the transmitter will still perform its function. Activating the ENTER key will clear the alarm. Should the sensor detect a level above 50% of the full scale range, the failure condition will be over-ridden and the output will immediately reflect the measured gas value.

**U.r. FAIL** : This message is displayed when the transmitter has detected a negative zero drift greater than 20% of full scale. The transmitter output is locked at 3 mA. The display will alternate between the current gas concentration and "U.r.". The unit should be checked for proper operation. Sensor zero should be set and system response should be checked. Activating the ENTER key will clear the alarm.

This condition is common with some types of sensors when a transmitter is initially installed. Some sensors exhibit a negative zero offset when they have been unbiased for a long period of time, such as when in storage. If this message appears on initial startup, allow the transmitter to run undisturbed for at least one to two hours. Then press ENTER and the condition will clear. Should the sensor detect a level above 50% of the full scale range, the failure condition will be over-ridden and the output will immediately reflect the measured gas value.

## SPARE PARTS

### Series A12 Two-Wire Gas Transmitter

<u>PART NO.</u>	<u>DESCRIPTION</u>
03-0071	Transmitter module (no enclosure or relay base)
03-0063	Transmitter x-proof enclosure, base, module connector
03-0111	Transmitter x-proof enclosure, base, module connector with 5 ft. cable
03-0070	Sensing module connector assembly with 8" cable
03-0065	Sensing module connector assembly with 5 ft. cable
03-0067	Earth GND Jumper
05-0021	Transmitter relay base with earth ground jumper (kit)
00-0248	D10 (no Auto-Test) Sensor Calibration Adapter
00-1197	D28 (w / Auto-Test) Sensor Calibration Adapter
00-0249	Flowcell assembly
45-0047	Splash guard
00-0210	Sensing module keeper
05-0017	Kit - Wall Mounting Bracket

#### SENSING MODULES (range for each module must be specified)

<u>No A/T (D10)</u>	<u>With Auto-Test (D28)</u>	
00-0211	00-0212	Bromine
00-0213	00-0214	Chlorine
00-0215	00-0216	Chlorine Dioxide
00-0217	00-0218	Fluorine
00-0219	00-0220	Ozone
00-0221	00-0222	Ammonia
00-0223	00-0224	Carbon Monoxide
00-0225	N/A	Hydrogen (PPM Range)
00-0260	N/A	Hydrogen (% Range)
00-0226	N/A	Oxygen
00-0227	N/A	Phosgene
00-0228	00-0229	Hydrogen Chloride
00-0230	00-0231	Hydrogen Cyanide
00-0232	00-0233	Hydrogen Fluoride
00-0234	00-0235	Hydrogen Sulfide
00-0236	N/A	Nitric Oxide
00-0237	00-0238	Nitrogen Dioxide
00-0239	00-0240	Sulfur Dioxide
00-0241	N/A	Arsine
00-0242	N/A	Diborane
00-0243	N/A	Germane
00-0244	N/A	Hydrogen Selenide
00-0245	N/A	Phosphine
00-0246	N/A	Silane
00-0247	N/A	Hydrogen Peroxide
00-0430	00-0431	Iodine
00-0682	N/A	Super High Range Phosphine (1000 PPM)
00-0785	N/A	Alcohol

**SENSOR ONLY**

<b><u>PART NO.</u></b>	<b><u>DESCRIPTION</u></b>
00-0264	E10-XX Low Range Oxidant Sensor (F <sub>2</sub> , Br <sub>2</sub> , I <sub>2</sub> , ClO <sub>2</sub> ), under 3 PPM
00-0265	E10-XX High Range Oxidant Sensor (F <sub>2</sub> , Br <sub>2</sub> , I <sub>2</sub> , ClO <sub>2</sub> ), 5 PPM & Above
00-0266	E10-27 Sulfur Dioxide Gas Sensor
00-0267	E10-15 Ammonia Gas Sensor
00-0268	E10-23 Hydrogen Fluoride Gas Sensor
00-0269	E10-21 Hydrogen Chloride Gas Sensor
00-0270	E10-22 Hydrogen Cyanide Gas Sensor
00-0271	E10-19 Oxygen Gas Sensor
00-0272	E10-18 Hydrogen Gas Sensor
00-0273	E10-24 Hydrogen Sulfide Gas Sensor
00-0274	E10-16 Carbon Monoxide Gas Sensor
00-0275	E10-25 Nitric Oxide Gas Sensor
00-0276	E10-26 Nitrogen Dioxide Gas Sensor
00-0277	E10-33 High Range Hydride (Silane) Gas Sensor
00-0278	E10-28 Low Range Hydride (0-1000 PPB) Gas Sensor
00-0279	E10-20 Phosgene Gas Sensor
00-0280	E10-34 Hydrogen Peroxide Gas Sensor
00-0292	E10-14 Low Range Ozone Gas Sensor
00-0681	E10-32 Super High Range Phosphine (1000 PPM)
00-0731	E10-39 Alcohol Gas Sensor
00-1111	E10-14 High Range Ozone Gas Sensor

**SENSOR AND GENERATOR**

00-0282	E28-14 Low Range Oxidant Sensor/Generator
00-0283	E28-11 Chlorine Gas Sensor/Generator
00-0284	E28-27 Sulfur Dioxide Gas Sensor/Generator
00-0285	E28-15 Ammonia Gas Sensor/Generator
00-0286	E28-23 Hydrogen Fluoride Gas Sensor/Generator
00-0287	E28-21 Hydrogen Chloride Gas Sensor/Generator
00-0288	E28-22 Hydrogen Cyanide Gas Sensor/Generator
00-0289	E28-24 Hydrogen Sulfide Gas Sensor/Generator
00-0290	E28-16 Carbon Monoxide Gas Sensor/Generator
00-0291	E28-26 Nitrogen Dioxide Gas Sensor/Generator
00-1112	E28-14 High Range Ozone Gas Sensor/Generator
00-1113	E28-14 Low Range Ozone Gas Sensor/Generator

**INSERTION SENSORS**

00-0815	G10-xx Lo Oxidant
00-0816	G10-xx Hi Oxidant
00-0817	G10-15 Ammonia
00-0818	G10-16 Carbon Monoxide
00-0819	G10-18 Hydrogen
00-0820	G10-19 Oxygen
00-0821	G10-20 Phosgene
00-0822	G10-21 Hydrogen Chloride
00-0823	G10-22 Hydrogen Cyanide
00-0824	G10-23 Hydrogen Fluoride
00-0825	G10-24 Hydrogen Sulfide
00-0826	G10-25 Nitric Oxide
00-0827	G10-26 Nitrogen Dioxide
00-0828	G10-27 Sulfur Dioxide
00-0829	G10-xx Lo Range Hydride
00-0830	G10-xx Hi Range Hydride
00-0831	G10-xx Super Hi Hydride
00-0832	G10-34 Hydrogen Peroxide
00-0833	G10-39 Alcohol
00-1109	G10-14 Low Range Ozone
00-1110	G10-14 High Range Ozone

# PRODUCT WARRANTY

Analytical Technology, Inc. (Manufacturer) warrants to the Customer that if any part(s) of the Manufacturer's products proves to be defective in materials or workmanship within the earlier of 18 months of the date of shipment or 12 months of the date of start-up, such defective parts will be repaired or replaced free of charge. Inspection and repairs to products thought to be defective within the warranty period will be completed at the Manufacturer's facilities in Collegeville, PA. Products on which warranty repairs are required shall be shipped freight prepaid to the Manufacturer. The product(s) will be returned freight prepaid and allowed if it is determined by the manufacturer that the part(s) failed due to defective materials or workmanship.

This warranty does not cover consumable items, batteries, or wear items subject to periodic replacement including lamps and fuses.

Gas sensors, except oxygen sensors, are covered by this warranty, but are subject to inspection for evidence of extended exposure to excessive gas concentrations. Should inspection indicate that sensors have been expended rather than failed prematurely, the warranty shall not apply.

The Manufacturer assumes no liability for consequential damages of any kind, and the buyer by acceptance of this equipment will assume all liability for the consequences of its use or misuse by the Customer, his employees, or others. A defect within the meaning of this warranty is any part of any piece of a Manufacturer's product which shall, when such part is capable of being renewed, repaired, or replaced, operate to condemn such piece of equipment.

This warranty is in lieu of all other warranties (including without limiting the generality of the foregoing warranties of merchantability and fitness for a particular purpose), guarantees, obligations or liabilities expressed or implied by the Manufacturer or its representatives and by statute or rule of law.

This warranty is void if the Manufacturer's product(s) has been subject to misuse or abuse, or has not been operated or stored in accordance with instructions or if the serial number has been removed.

Analytical Technology, Inc. makes no other warranty expressed or implied except as stated above.

## WATER QUALITY MONITORS

Dissolved Oxygen  
Free Chlorine  
Combined Chlorine  
Total Chlorine  
Residual Chlorine Dioxide  
Potassium Permanganate  
Dissolved Ozone  
pH/ORP  
Conductivity  
Hydrogen Peroxide  
Peracetic Acid  
Dissolved Sulfide  
Residual Sulfite  
Fluoride  
Dissolved Ammonia  
Turbidity  
Suspended Solids  
Sludge Blanket Level

**MetriNet** Distribution Monitor

## GAS DETECTION PRODUCTS

NH <sub>3</sub>	Ammonia
CO	Carbon Monoxide
H <sub>2</sub>	Hydrogen
NO	Nitric Oxide
O <sub>2</sub>	Oxygen
CO	Cl <sub>2</sub> Phosgene
Br <sub>2</sub>	Bromine
Cl <sub>2</sub>	Chlorine
ClO <sub>2</sub>	Chlorine Dioxide
F <sub>2</sub>	Fluorine
I <sub>2</sub>	Iodine
H <sub>x</sub>	Acid Gases
C <sub>2</sub> H <sub>4</sub> O	Ethylene Oxide
C <sub>2</sub> H <sub>6</sub> O	Alcohol
O <sub>3</sub>	Ozone
CH <sub>4</sub>	Methane (Combustible Gas)
H <sub>2</sub> O <sub>2</sub>	Hydrogen Peroxide
HCl	Hydrogen Chloride
HCN	Hydrogen Cyanide
HF	Hydrogen Fluoride
H <sub>2</sub> S	Hydrogen Sulfide
NO <sub>2</sub>	Nitrogen Dioxide
NO <sub>x</sub>	Oxides of Nitrogen
SO <sub>2</sub>	Sulfur Dioxide
H <sub>2</sub> Se	Hydrogen Selenide
B <sub>2</sub> H <sub>6</sub>	Diborane
GeH <sub>4</sub>	Germane
AsH <sub>3</sub>	Arsine
PH <sub>3</sub>	Phosphine
SiH <sub>4</sub>	Silane
HCHO	Formaldehyde
C <sub>2</sub> H <sub>4</sub> O <sub>3</sub>	Peracetic Acid
DMA	Dimethylamine