

**DISASSEMBLY
AND ASSEMBLY
INSTRUCTIONS FOR
LIQUID RING VACUUM PUMPS
WITH MECHANICAL SEALS**

**TRH - TRS 32 to 125
TRV 65**



INTRODUCTION

These instructions are for the maintenance staff in case of repair for the following pumps:

TRHE 32-20 to 60	TRSE 32	TRVA 65
TRHC 40-110	TRSC 40	
TRHE 40-110	TRSE 40	
TRHC 40-140 & 190	TRSC 50	
TRHE 40-140 & 190	TRSE 50	
TRHB 50	TRSB 100	
TRHC 80	TRSC 100	
TRHE 100	TRSE 125	

These instructions are supplied and integrated with the manual of "INSTALLATION, OPERATION AND MAINTENANCE INSTRUCTIONS FOR LIQUID RING VACUUM PUMPS". They provide a reference for safe operation, installation, maintenance and repairing of the pumps.

Prior to working on the pump, it is recommended to follow the instructions of safety listed in chapters 2 and 15 of the above manuals, and is absolutely important to:

- wear safety clothing, hard hat, safety shoes, safety eye glasses
- disconnect the electrical power
- close suction valves and service liquid valves
- remove pump from installation without damaging other system components
- assume all safety measures if pump has been handling dangerous fluids
- drain pump casings through the draining connections and flush the pump with clean liquid, if required.

When requesting spare parts or technical information for the pump, always quote the pump model number and serial number which is printed on the pump nameplate: therefore, it is recommended not to remove the pump nameplate or, in case this action will be necessary, write the serial number on the pump (for example on the flange).

Should additional information be required, please do not hesitate to contact POMPETRAVAINI or the closest representative. Should there be any difficulties in repairing the pump, it is recommended to send the pump for repair to POMPETRAVAINI or the local authorised representative.

Any pump repairs and/or system work carried out by others will not be guaranteed by POMPETRAVAINI.

NOTE: VDMA numbers identify all pump components. Refer to parts list in chapter 9 and to the section drawings in chapter 10.

All drawings are schematic only and are not certified for construction.

For further information please consult POMPETRAVAINI or its closest representative.

Torque values of various bolt sizes and tie-bolts are listed on fig. 34 and tab. 13.

INDEX

- 1- **Disassembly to replace bearings and/or mechanical seals**
- 2- **Mechanical seal assembly**
 - 2.1- *Assembly of the stationary part in the bearing housing*
 - 2.2- *Assembly of the rotating part on the shaft*
- 3- **Bearing assembly**
 - 3.1 - *Securing the bearings (not for pumps series 32 but applicable for TRHE 32-.../X)*
- 4- **Bearing lubrication**
- 5- **Total pump disassembly**
- 6- **Machining the pump parts**
 - 6.1- *Typical schematics for machining to restore clearances - Pumps series "TRH"*
 - 6.2- *Typical schematics for machining to restore clearances - Pumps series "TRS ÷ TRV"*
- 7- **Pump assembly**
 - 7.1 - *Pumps series" TRHE & TRSE 32"*
 - 7.2 - *Pumps series "TRHE 32-.../X ÷ TRH 40 to 100 ÷ TRS 40 to 125 ÷ TRV 65"*
 - 7.3 - *Axial regulation for pumps series "TRHC 80-.../1-C"*
- 8- **Recommended spare parts**
- 9- **Parts list**
- 10 - **Typical sectional drawings**



The liquids and the gases handled by the pumps and also their parts could be potentially dangerous for persons and environment: provide their eventual disposal in conformity with the laws into force and a proper environment management.



The present manual is not assigned for pumps subjected to the ATEX 2014/34/EU directive. In case the pump is assigned in environments subjected to the application ATEX 99/92/CE directive or in case the pump is provided with a nameplate indicating the ATEX stamp, it is strictly forbidden proceed to start up the pumps but necessary to consult POMPETRAVAINI for clarifications.

For pumps subjected to the ATEX 2014/34/EU directive it is available a dedicated integrative manual.

In preparing this manual, every possible effort has been made to help the customer and operator with the proper installation and operation of the pump. Should you find errors, misunderstandings or discrepancies please do not hesitate to bring them to our attention.

1 - DISASSEMBLY TO REPLACE BEARINGS AND/OR MECHANICAL SEALS

The pumps are manufactured in such a manner as to make it possible to replace the mechanical seals and the bearings without total disassembly of the pump, but only by removing the bearing housings VDMA 357 or VDMA 350.

Bearing housing disassembly can be carried out by following the sequence listed on Tables 1A, 1B and 2A, 2B. Following the row of the specific pump model, find the sequence and the numeric quantity of the components to be disassembled. In order to remove the bearing housings a suitable gear puller is required.

NOTE: Pumps series 32 have free floating impellers. To prevent the shaft from sliding out of the pump, it is recommended to remove and replace the mechanical seal, bearing housing and bearings one side at a time, or make provision to secure the shaft so it does not slide out of the pump.

WARNING: Handle the mechanical seals with care to prevent damaging their most delicate parts.

Tab. 1A - DISASSEMBLY OF BEARING AND MECHANICAL SEAL - DRIVE END

PART VDMA N°	PIPE	CIRCLIP	HEX SOCKET OVAL HEAD SCREW	HEX SOCKET HEAD CAP SCREW	HEX HEAD SCREW	BEARING COVER		V-RING SEAL	CIRCLIP	NUT	HEX SOCKET HEAD CAP SCREW	HEX HEAD SCREW	BEARING HOUSING	
						365	360						357	357.1
PUMPS SERIES	701	932.3	914.B	914	901	365	360	427	932	923	914.1	901	357	357.1
TRHE 32-20 ÷ 60 TRSE 32		1				1			1		4		1	
TRHC 40-110 TRSC 40		1				1			1		4		1	
TRHE 40-110 TRSE 40		1				1			1		4			1
TRHC 40- 140 & 190 TRSC 50		1				1			1		4		1	
TRHE 40- 140 & 190 TRSE 50		1				1			1		4			1
TRHB 50	1			4			1			1	4			1
TRSB 100				4			1			1		4	1	
TRHC 80 TRSC 100				1			1			1		4	1	
TRHC 80- .../1-C			3			1		1	1			4	1	
TRHE 100 TRSE 125					4		1			1		4	1	
TRVA 65				4			1			1	4			1

Tab. 1B - DISASSEMBLY OF BEARING AND MECHANICAL SEAL - DRIVE END

PART VDMA N°	BEARING		RADIAL SEAL RING	ELASTIC RING	SHOULDER RING		O-RING	SEAL	SEAL HOUSING BUSHING	MECHANICAL SEAL	MECHANICAL SEAL RING
	320	326.C			421	935					
PUMPS SERIES	320	326.C	421	935	505	505.1	412	401	547	433.2	485
TRHE 32-20 ÷ 60 TRSE 32	1				1			1		1	
TRHC 40-110 TRSC 40	1				1			1		1	
TRHE 40-110 TRSE 40	1				1			1		1	
TRHC 40- 140 & 190 TRSC 50	1				1			1		1	
TRHE 40- 140 & 190 TRSE 50	1				1			1		1	
TRHB 50	1				1			1		1	
TRSB 100	1				1			1		1	1
TRHC 80 TRSC 100	1				1			1		1	
TRHC 80- .../1-C	1		1		1			1	1(A3)	1	
TRHE 100 TRSE 125			1	1	1	1		1		1	
TRVA 65	1				1			1		1	1

Tab. 2A - DISASSEMBLY OF BEARING AND MECHANICAL SEAL - NON DRIVE END

PART VDMA N°	PIPE	CIRCLIP	HEX SOCKET OVAL HEAD SCREW	BEARING COVER	HEX SOCKET HEAD CAP SCREW	HEX HEAD SCREW	BEARING COVER		ELASTIC RING	HEX SOCKET HEAD CAP SCREW	GRUB SCEW	NUY	SHOULDER RING	CIRCLIP
PUMPS SERIES	701	932.3	914B.2	364	914.1	901	365.1	361	904	914	904B	923A	505.1	932
TRHE 32-20-60 TRSE 32		1					1							1
TRHC 40-110 TRSC 40					4			1				1		
TRHE 40-110 TRSE 40		1					1					1		
TRHC 40- 140 & 190 TRSC 50					4			1				1		
TRHE 40- 140 & 190 TRSE 50					4			1				1		
TRHB 50	1				4			1				1		
TRSB 100					4			1				1		
TRHC 80 TRSC 100					4			1				1		
TRHC 80- .../1-C			2	1	4			1		3	3	1	1	
TRHE 100 TRSE 125						4		1				1		
TRVA 65					4			1				1		

Tab. 2B - DISASSEMBLY OF BEARING AND MECHANICAL SEAL - NON DRIVE END

PART VDMA N°	BEARING BRACKET + BEARING	ELASTIC RING	HEX SOCKET HEAD CAP SCREW	HEX HEAD SCREW	BEARING HOUSING		BEARING	SHOULDER RING	SEAL HOUSING BUSHING	O-RING	SEAL	MECHANICAL SEAL	MECHANICAL SEAL RING.		
PUMPS SERIES	358 + 321	935	914.1	901	901.1	357	357.1	320	505 + 505.1	542	412	400.2	433.1	485	485.1
TRHE 32-20-60 TRSE 32		1	4			1		1	1+1			1	1		
TRHC 40-110 TRSC 40				4		1	1	1				1	1	1	
TRHE 40-110 TRSE 40		1	4			1	1	1				1	1		
TRHC 40- 140 & 190 TRSC 50				4		1	1	1				1	1	1	
TRHE 40- 140 & 190 TRSE 50			4			1	1	1				1	1	1	
TRHB 50					4	1	1	2				1	1	1	
TRSB 100					4	1	1	2				1	1	1	
TRHC 80 TRSC 100					4	1	1	2				1	1		
TRHC 80- .../1-C	1+1			4		1		1	1(A3)			1	1		
TRHE 100 TRSE 125					4	1	1	2				1	1	1	
TRVA 65			4			1	1	2				1	1		1

Inspect the disassembled components and procure all original spare parts such as bearings, mechanical seals, gaskets, seal rings, etc. Any non-original spare parts, shall be dimensionally compatible with the sizes and performances of the original component. Carefully clean all parts that are still in good conditions.
See chapters 2 and 3 for disassembly instructions of mechanical seals and bearings.

NOTE (A3) : refer to the seal housing bushing (VDMA 542) present only in pumps A3 execution.

2 - MECHANICAL SEAL ASSEMBLY

NOTE: The mechanical seals mounted on the pumps are of standard type according to DIN 24960/K (shorter working length "L1").

Prior to assembly, check the dimensions of the cavities for the mechanical seal VDMA 433.1 and/or 433.2. Critical dimensions are "ØG" and "F" on the bearing housing VDMA 357 and/or 357.1 (or on the bushing VDMA 542, when provided), dimension "ØD" of the shaft VDMA 210, dimension "L" from the casings VDMA 106/107 to the ring VDMA 485 (when provided) or the shoulder on shaft VDMA 210 (see drawing fig.1 and dimensions listed on tab. 3).

Restore, if necessary, the required working dimension "L1" of the mechanical seals by adjusting the location of ring VDMA 485 (when provided) or adding spacer or machining the shoulder of the shaft VDMA 210 (whenever possible).

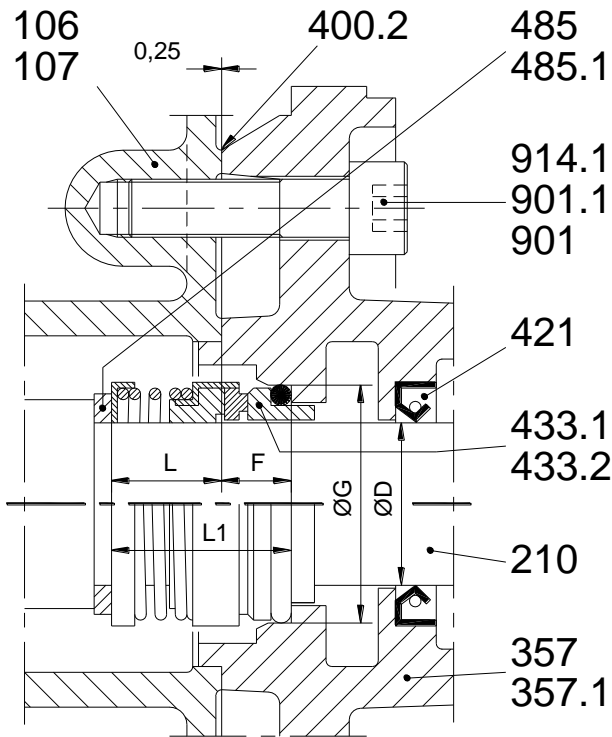

Fig. 1 - Typical drawing of mechanical seal with dimensions valid for both pump ends

Tab. 3 - DIMENSIONS FOR THE MECHANICAL SEALS

PUMPS SERIES	Ø D h6	F	Ø G H8	L	L1 ±0,5
TRHE 32-20 to 60 TRSE 32	22	2	37	35,5	37,5
TRHE 40-110 TRSE 40	28	18	43	24,5	42,5
TRHC 40 TRHE 40-140 & 190 TRSC 40 TRSE 50	35	25	50	17,5	
TRHB 50 TRVA 65	43	16	61	29	
TRHC 80 TRSB 100 TRSC 100	55	3,5	75	44	47,5
TRHE 100 TRSE 125	75	2	97	58	60

2.1 - ASSEMBLY OF THE STATIONARY PART IN THE BEARING HOUSING

The seat in the bearing housing VDMA 357 or 357.1 where the seal ring fits, shall be perfectly clean and without machining tool markings.

Moisten (using water, liquid soap, etc., but avoiding the use of oils) the seat in the housing and the O-Ring of the stationary part of the mechanical seal.

Push the stationary part of the mechanical seal into the housing using a plunger covered with heavy paper board or similar material. The plunger must exert a force perpendicularly to the axis of the piece; for this purpose use either an harbour press or the spindle of a drill (see fig. 2).

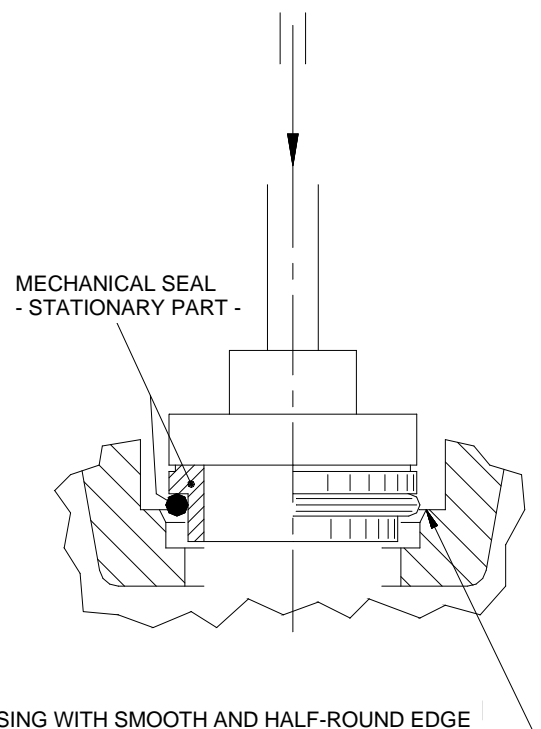

Fig. 2

2.2 - ASSEMBLY OF THE ROTATING PART ON THE SHAFT

The area of the shaft VDMA 210 where the seal fits shall be smooth, clean, without sharp edges and moistened (using water, liquid soap, etc: but avoiding the use of oils). Even if the shaft has been ground, it shall be polished again with extra fine sand paper or emery cloth.

Insert the ring VDMA 485 on the shaft (when provided), slip on the whole rotating part of the mechanical seal on the conic sleeve "A", or any similar tool (see fig. 3). The surface of the sleeve should be smooth and moistened (using water or liquid soap etc. but avoiding the use of oils).

Gently push the rotating part of the seal, with the help of a tool similar to the device "B", until it rests against the VDMA 485 or the shaft shoulder.

NOTE: Mechanical seals that are designed for specific direction of rotation must be fitted on the pump shaft end having that particular direction of rotation.

Example: Pump with clockwise rotation (viewed from drive-end) requires mechanical seal designed for right rotation at the drive-end side and seal for left rotation at non-drive-end side.

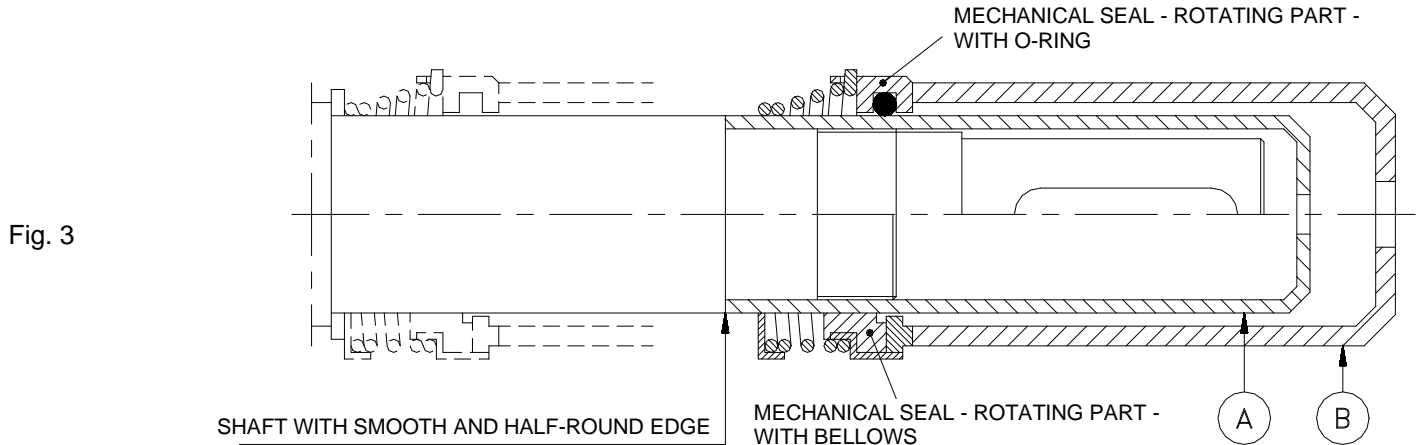

Fit mechanical seal stationary seat and gasket VDMA 400.3 on seal cover VDMA 471. Fit seal cover on pump housing VDMA 106 or 107 and fasten it with bolts VDMA 914. Install bearing housing VDMA 357 complete with radial seal ring VDMA 421 (see fig 4.).

NOTE: Bearing housing draining connection should be positioned toward the bottom.

Provided that the tie-bolts VDMA 905 (and the pump components between them) have never been moved, the bolts VDMA 901.1 can now be tightened to pump housing VDMA 106 and/or 107.

Assembly the seal flushing line VDMA 701, where applicable.

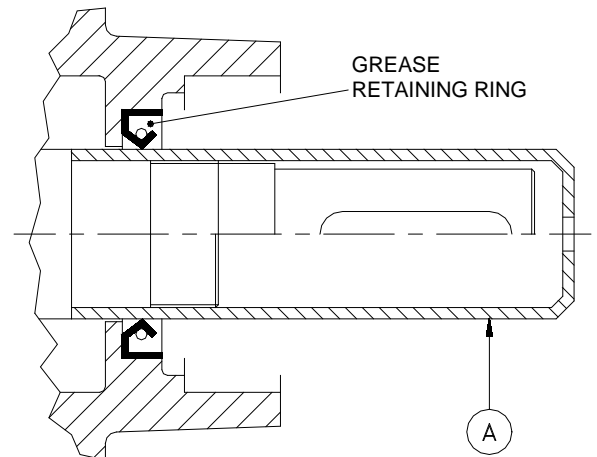

Fig. 4

3 - BEARING ASSEMBLY

Bearing assembly can only start after the pump has been fitted with mechanical seals and seal housing VDMA 357 or bearing housing VDMA 350, as described in chapter 2.

NOTE: Pumps series 32 (not for construction TRHE32-.../X) have free floating impellers. To prevent the shaft from sliding out of the pump, it is recommended to replace the bearing at non drive end first, or make provision to secure the shaft so it does not slide out of the pump.

Proceed with the assembly following the steps given on tab. 4 and 5 which indicate, on the row of the pump concerned, the sequence and the numeric quantity of the components to be assembled (for additional information see instructions on the following pages).

NOTE: All pumps in the "STANDARD" design, except series TRHE 100 and TRSE 125, are fitted with locked bearings at the non-drive end. Therefore, the non-drive end bearing will locate the rotor within the pump while the bearing at the drive end is free to slide in its housing.

See fig. 5 to 8 for locking the bearing and tab. 6 for bearing details.

Tab. 4 - BEARING ASSEMBLY - DRIVE END

PART VDMA N°	SHOULDER RING		BEARING		ELASTIC RING	ANELLO SEEGER	CIRCLIP	NUT	BEARING COVER		CIRCLIP	SCREWS	HEX HEAD SCREW
	505	505.1	320	323	935	932	411	923	365	360	932.3	914	901
TRHE 32-20 ÷ 60 TRSE 32	1		1			1			1		1		
TRHC 40-110 TRSC 40	1		1			1			1		1		
TRHE 40-110 TRSE 40	1		1			1			1		1		
TRHC 40- 140 & 190 TRSC 50	1		1			1			1		1		
TRHE 40- 140 & 190 TRSE 50	1		1			1			1		1		
TRHB 50	1		1					1			1	4	
TRSB 100	1		1					1			1	4	
TRHC 80 TRSC 100	1		1					1			1	4	
TRHC 80-.../1-C	1		1			1	1		1			3	
TRHE 100 TRSE 125	1	1		1	1			1			1		4
TRVA 65	1		1					1			1	4	

Tab. 5 - BEARING ASSEMBLY - NON DRIVE END

PART VDMA N°	HEX SOCKET HEAD CAP SCREW	GRUB SCREW	SHOULDER RING	ELASTIC RING	BEARING	NUT	ELASTIC RING	CIRCLIP	BEARING COVER		CIRCLIP	SCREW	VITI TE	BEARING COVER	HEX SOCKET HEAD CAP SCREW
	914	904	505 + 505.1	935	320	923	935	932	365.1	360.1	932.3	914	901	365.2	914.5
TRHE 32-20 ÷ 60 TRSE 32			1+1		1		1	1	1		1				
TRHC 40-110 TRSC 40			1	1	1	1				1		4			
TRHE 40-110 TRSE 40			1	1	1	1	1		1		1				
TRHC 40- 140 & 190 TRSC 50			1	1	1	1				1		4			
TRHE 40- 140 & 190 TRSE 50			1	1	1	1				1		4			
TRHB 50			2	1	1	1				1		4			
TRSB 100			2	1	1	1				1		4			
TRHC 80 TRSC 100			2	1	1	1				1		4			
TRHC 80-.../1-C	3	3	1		1	1				1		3	1	1	2
TRHE 100 TRSE 125			2	1	1	1				1			4		
TRVA 65			2	1	1	1				1		4			

See fig. 5 to 8 for locking the bearings on "STANDARD" or "BELT DRIVE" pump designs (series 32 not available with belt drive).

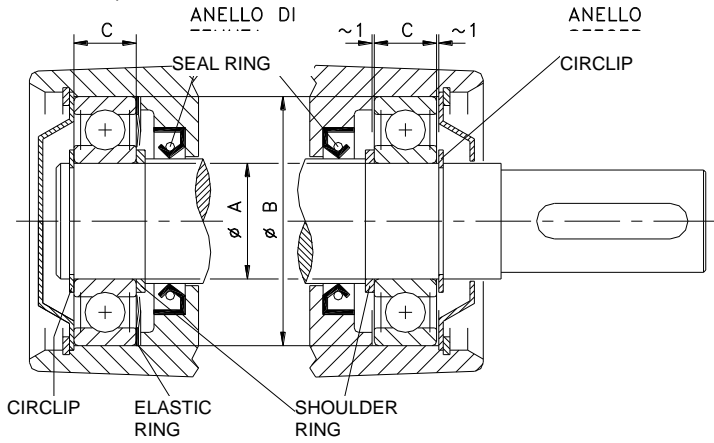

Fig. 5
Locking of bearings (STANDARD only)
For pumps series

TRHE 32-20 to 60
TRSE 32

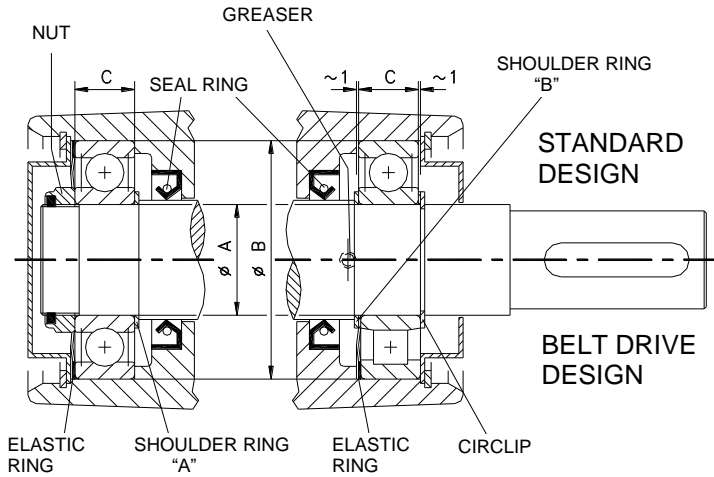

Fig. 6
Locking of bearings for pumps series

TRHE 40-110
TRSE 40

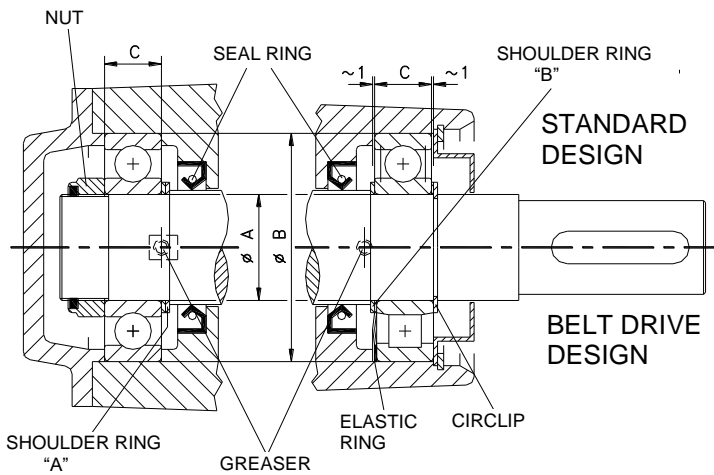

Fig. 7
Locking of bearings for pumps series

TRHE 32 -.../X
TRHC 40 and TRHE 40-140 & 190
TRSC 40 & 50 and TRSE 50

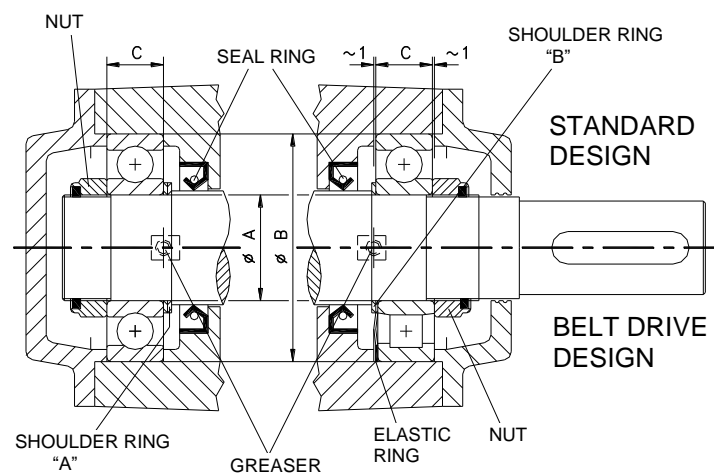

Fig. 8
Locking of bearings for pumps series

TRHB 50 - TRHC 80 - TRSB 100
TRSC 100 & TRVA 65

TRHE 100
TRSE 125

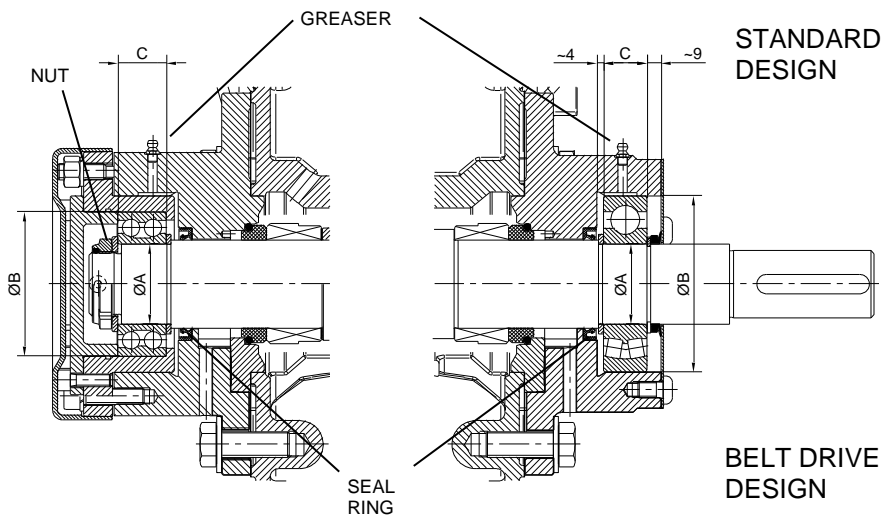

Fig. 9
Locking of bearings for pumps series:

TRHC 80-.../1-C

Tab. 6 - DIMENSIONS AND DETAILS OF BEARINGS

PUMPS SERIES	BEARING DIMENSIONS					QUANTITY OF GREASE FOR BEARING in grams
	Ø A	Ø B	C	BALL BEARING TYPE	ROLLER BEARING TYPE (*)	
TRHE 32-20 ÷ 60 TRSE 32	20	52	15	6304-2RS	---	---
TRHE 40-110 TRSE 40	25	62	17	6305-2RS	NU 305	20
TRHC 40 TRHE 40-140 & 190 TRSC 40 TRSC 50 TRSE 50	30	72	19	6306-2RS	NU 306	30
TRHB 50 TRVA 65	40	90	23	6308	NU 308	50
TRHC 80 TRSB 100 TRSC 100	50	110	27	6310	NU 310	100
TRHC 80-.../1-C NON DRIVE END	50	90	30.2	3210B	-	70
TRHC 80-.../1-C DRIVE END	50	110	27	6310-C3	-	55
	50	110	27	-	21310	55
TRHE 100 TRSE 125	70	150	35	6314	NU 314	300

(*) For Belt drive

3.1 - SECURING THE BEARINGS (NOT FOR ALL PUMPS SERIES 32 BUT APPLICABLE TO TRHE 32 -.../X)

Bearing shall be locked in such a way that the impellers VDMA 230 and 230.1 are centred within their own housing. To find the "A" dimension (thickness) for the shoulder rings VDMA 505 on the non-drive end, the pump must have been assembled up to the bearing housings VDMA 357 and/or 357.1 excluding the bearings VDMA 320 and/or 323 and the bearing shoulder rings (see fig. 9 and 10).

- Using a gear puller or other suitable tool, push the shaft VDMA 210 in the "X" direction and measure the "X1" dimension (from the shaft shoulder to the face of the bearing housing).
- Repeat the operation pushing the shaft in the "Y" direction and measure the "Y1" dimension (always from the shaft shoulder to the face of bearing housing).
- Measure the "P" dimension (depth of the bearing box).
- Apply the equation $A = [(X1 + Y1) / 2] - P$ which will determine the thickness of spacer VDMA 505.

Finding the "B" dimension that is the thickness of the shoulder ring for the drive end, will depend upon the type of bearing design.

For the "STANDARD" pump design, "B" dimension shall be such as to leave a clearance of about 1 mm on each side of the bearing on the drive side (see fig. 9).

Instead, for the "BELT DRIVE" design, "B" dimension shall be such as to place the bearing against the face of the bearing cover VDMA 365.1 or 360.1 and to leave all the clearance (about 2 mm) on the side of the bearing housing, that is required for the assembly of the elastic ring VDMA 935 (see fig. 10).

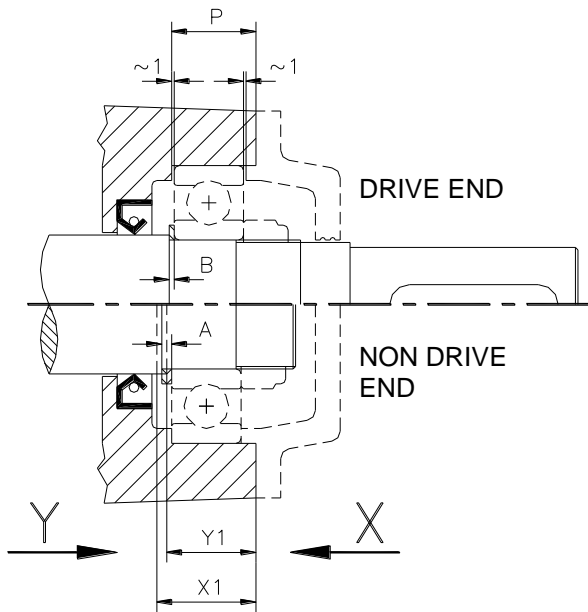

Fig. 9
"STANDARD" design

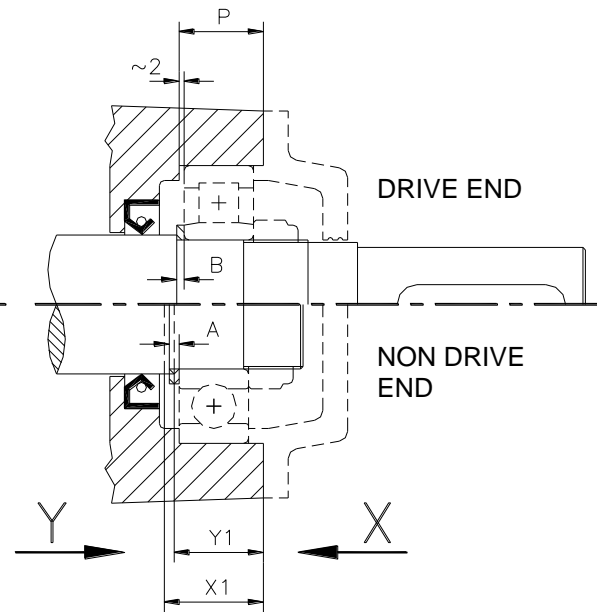

Fig. 10
"BELT DRIVE" design

3.2 – AXIAL REGULATION FOR PUMP SERIES TRHC 80-.../1-C

The pumps of the TRHC 80-.../1-C series are equipped with the possibility of axially adjusting the position of the shaft and of the impellers locked on it to optimize the distribution of the clearances and therefore the performance of the pump. In order to proceed with the axial adjustment, the VDMA 360.1 bearing cover must be accessible, fixed with the socket head cap screws VDMA 914.6.

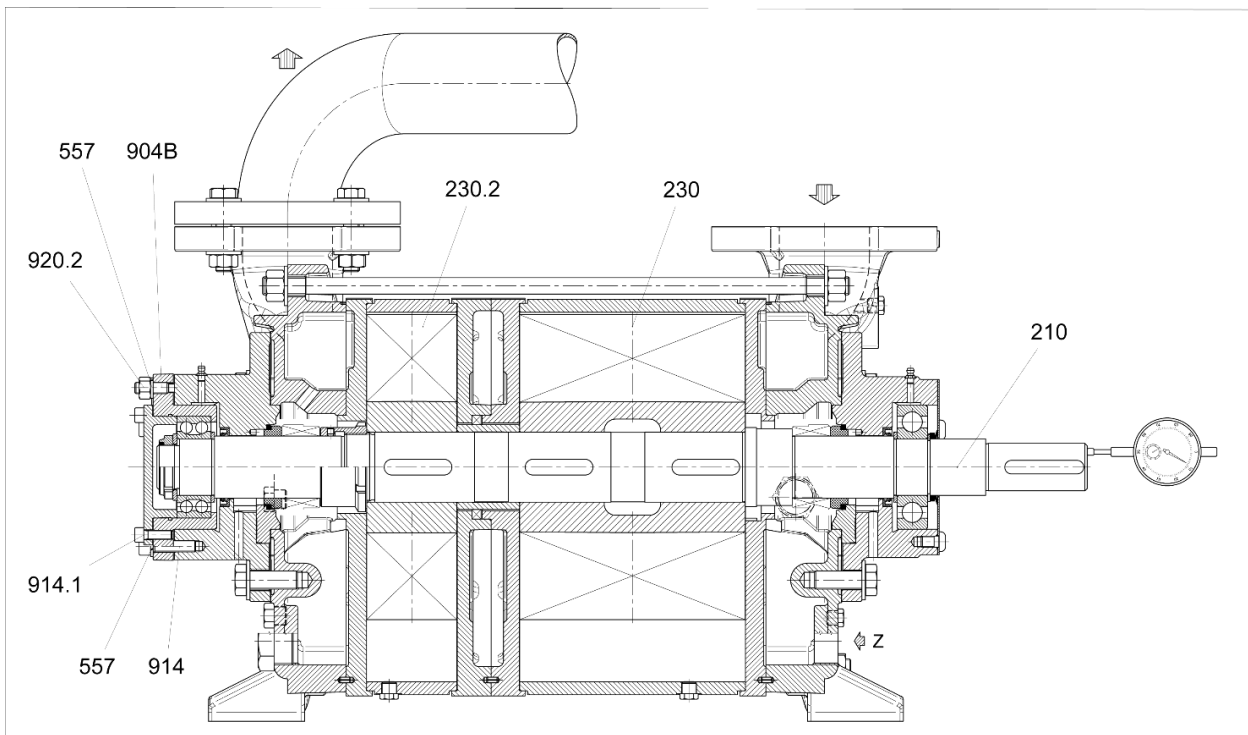

Fig. 10

Act alternately on the VDMA 904 grub screws and on the VDMA 914 TCEI screws to determine the total clearance of the VDMA 210 shaft/VDMA 230 and 230.2 impeller unit with respect to the pump elements and then block them so that the shaft/impeller unit is positioned exactly in the middle to the clearance available.

Preferably use a centesimal dial gauge resting on the VDMA 210 shaft drive (see Fig. 10).

If the total clearance does not fall within the tolerances indicated in tab. 4 the pump needs maintenance. Check that the pump turns freely by hand and that there is no rubbing inside, then fit the bearing cover VDMA 365.2, fixing it with the TBEI screws VDMA 914.5.

4 - BEARING LUBRICATION

Lubrication of greased open bearings must be done in compliance with the instructions of the bearing manufacturer. Pumps with standard operating conditions, should have their bearings lubricated after maximum 1000 working hours. In any case, always check the bearing's operation for unusual high temperature and noise level. When considering reusing the bearings, it is recommended to remove the old grease and any dirt from the bearing running faces and seal rings, then fill with new lubricating grease. The lubricant type used by us is type "EP 3", grease with temperature range from -30 °C to +140 °C. It is recommended not to mix different types of grease. Equivalent grease or grease with greater performances can be used. Before starting the pump, it is good practise to grease the bearings with a suitable grease gun. The maximum quantity of required lubricant is listed on tab. 6. Lubrication intervals may be increased depending upon the operating temperatures and the bearing loads.

5 - TOTAL PUMP DISASSEMBLY

NOTE: In the event the mechanic assigned to this work is not very skilled, it is suggested to mark the location (rotation and assembly sequence) for the various parts prior to starting the disassembly. However, most parts have a locating marking at 12 O'clock position that can be used as a reference for their position.

A wrong location of the parts can cause a partial or even a total lack of pump performance.

Drain the pump of any residual liquid, prior to disassembly. With the pump in the horizontal position begin the disassembly at the bearing housings and the mechanical seals (see chapter 1).

Then place the pump in the vertical position on a sturdy stand similar to the one illustrated on fig. 28 to 31 (section of heavy-duty pipe or similar stand) and proceed to disassemble the whole pump (pumps series 32 can also be disassembled in the horizontal position).

Use proper tools and follow a correct disassembly method to avoid damaging the pump components.

See tab. 7 or 8 (by pumps series), for the sequence and the numeric quantity of parts to disassemble; to help with the identification and the location of all components consult also the sectional drawings on chapter 10.

NOTE for pumps series TRHE 100, TRSB 100, TRSC 100, TRSE 125, TRVA 65.

If it was necessary to remove also the impellers VDMA 230 (and 230.1 in case of pumps series TRH), unscrew the nuts VDMA 922 or 922.1, heat the impeller (which were shrink-fitted) and extract them from the shaft VDMA 210 using an hydraulic press.

After pump disassembly inspect all parts for their integrity. If they are in sound condition, clean the parts and remove the gasket material from the sealing faces with a nitro-cellulose thinner.

If the parts require machining, follow the instructions given on chapter 6.

When original spare parts are used, check that they are compatible with the new dimensions obtained by machining the parts.

For the recommended spare parts see chapter 8.

Tab. 7 - TOTAL PUMP DISASSEMBLY - PUMPS SERIES "TRH"

COMPONENT VDMA No.	Step I			Step II						
	BOLT	MANIFOLD	GASKET	TIE-BOLT	SUCTION CASING	PIN	PORT PLATE	GASKET	IMPELLER CASING	GASKET
PUMPS SERIES	901.8	147	400.8	905	106	561	137.1	400	110	400
TRHE 32-20 & 45				3	1			1		
TRHE 32-60	4	1	2	3	1			1		
TRHC 40-110				4	1	1	1	1	1	1
TRHE 40-110				4	1			1	1	1
TRHC 40- 140 & 190	8	1	2	4	1	1	1	1	1	1
TRHE 40- 140 & 190	8	1	2	4	1			1	1	1
TRHB 50	8	1	2	5	1			1	1	1
TRHC 80	8	1	2	5	1	1	1	1	1	1
TRHE 100	16	1	2	7	1			1	2	2

⇒ (to be continued)

(continuation) →		Step III						Step IV									
COMPONENT VDMA No.	DISCHARGE CASING	PIN	PORT PLATE	GASKET	IMPELLER CASING	GASKET	NUT		SPACER SLEEVE	2nd STAGE IMPELLER	PORT PLATE	PIN	PORT PLATE	INTERMEDIATE ELEMENT		SPACER SLEEVE	1st STAGE IMPELLER
PUMPS SERIES	107	561	137.4	400	110.1	400	922	922.1	525	230.1	137.3	561	137.2	140	140.1	521	230
TRHE 32-20 to 60	1			1						1				1			1
TRHC 40-110/ GH - F - RA	1	1	1			1		1	1	1				1		1	1
TRHC 40-110/ B2 - A3	1	1	1	1	1	1	2		1	1	1	1	1			1	1
TRHE 40-110	1					1	2			1				1		1	1
TRHC 40- 140 & 190/ GH - F - RA	1	1	1			1		1	1	1				1		1	1
TRHC 40- 140 & 190/ B2 - A3	1	1	1	1	1	1	2		1	1	1	1	1			1	1
TRHE 40- 140 & 190	1					1	2			1				1		1	1
TRHB 50/ GH - F - RA	1					1		1		1					1	1	1
TRHB 50/ B2 - A3	1			1	1	1	2			1				1		1	1
TRHC 80	1	1	1	1	1	1	1			1	1	1	1			1	1
TRHE 100	1			1	1	1	2			1				1		1	1

Tab. 8 - TOTAL PUMP DISASSEMBLY - PUMPS SERIES "TRS - TRV"

COMPONENT VDMA No.	Step I			Step II						Step III				Step IV				
	BOLT	MANIFOLD	GASKET	TIE-BOLT	SUCTION CASING	PIN	PORT PLATE	GASKET	IMPELLER CASING	GASKET	DISCHARGE CASING	PIN	PORT PLATE	NUT		SPACER SLEEVE	IMPELLER	
PUMPS SERIES	901.8	147	400.8	905	106	561	137.1	400	110	110.1	400	107	561	137.4	922	922.1	525	230
TRSE 32				3	1			1	1		1	1						1
TRSC 40-55 ÷ 100				4	1	1	1	1	1		1	1	1	1		1	1	1
TRSC 40-150	8	1	2	4	1	1	1	1	1		1	1	1	1		1	1	1
TRSE 40				4	1			1	1		1	1		2				1
TRSC 50	16	2	4	4	1	1	1	1	1		1	1	1	1		1	1	1
TRSE 50	16	2	4	4	1			1	1		1	1		2				1
TRSB 100	16	2	4	7	1			1	1	1	2	1		2				1
TRSC 100	16	2	4	5	1	1	1	1	1		1	1	1	1				1
TRSE 125	32	2	4	7	1			1	1	1	2	1		2				1
TRVA 65	16	2	4	5	1	1	1		1		1	1	1	2				1

6 - MACHINING THE PUMP PARTS

Liquid ring vacuum pumps achieve their best efficiency when the tolerance between the impeller and the port plates are within certain limits: lower tolerances could lead to pump seizing while higher tolerances could result in loss of pump capacity and vacuum level.

When machining is required to refurbish the faces of the port plates, it is of the utmost importance to keep the surfaces parallel, flat and within the permissible dimensions. Do not remove more than 0,5 mm each face.

Fig. 11 or 12 and tab. 9 illustrate the location and the recommended original clearance between each side of impeller(s) face and their respective port plates (pumps series 32 are fitted with free floating impellers that will automatically seek the centre between the two port plates).

NOTE: Upon completion of pump assembly the attained final total clearance between impeller(s) and port plates (double that of each side), could be less than the original suggested. However, this total clearance should not be less than 0,3 mm or 0,15 mm each side (0,4 total or 0,2 mm each side for pumps series TRHE 100 and TRSE 125). Lesser clearances will greatly increase the risk of pump seizing during operation (refer to equation $X1 - Y1 \geq 0,3$ mm on page 8).

When machining is required, it is recommended to begin machining the sides of impeller(s) VDMA 230(.1) attaining therefore a uniform dimension "H1" (see fig. 13 to 20).

Follow with machining of impeller casing(s) VDMA 110(.1) or intermediate element VDMA 140 or 140.1 to dimension "H" taking into account the required clearance and the gasket thickness that will be used between impeller centre-body (s) and casings VDMA 106 and 107, or the port plates VDMA 137(.1) (.2) (.3) (.4).

When the gasket is liquid compound, allow a thickness of about 0,05 mm, see chapter 7.2.

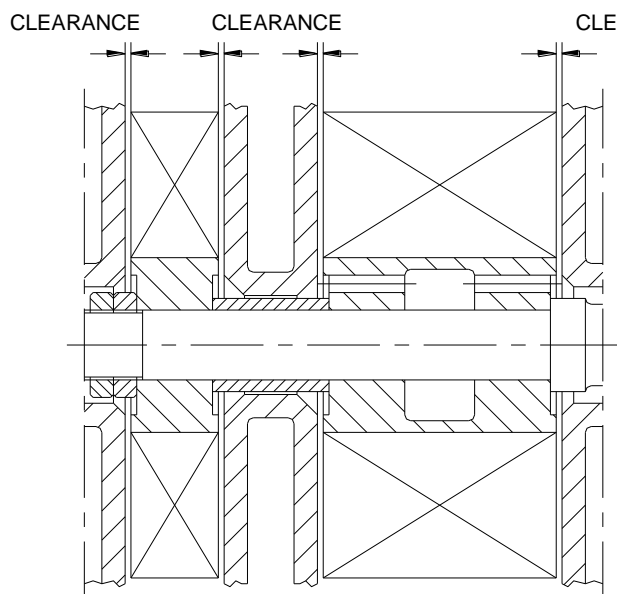

Fig. 11 - Pumps series TRH

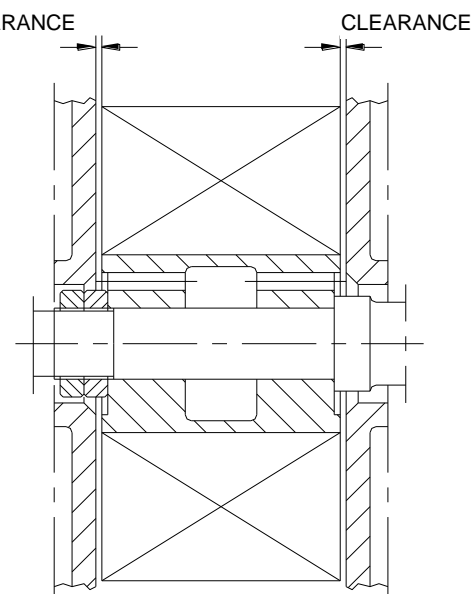

Fig.12 - Pumps series TRS - TRV

To summarise: Sum of dimension "H" and thickness of gasket material for each side equals the sum of dimension "H1" and the 2 recommended original clearances.

Then proceed with machining of port plates if required.

All these machining operations will result in a shorter pump: consequently, the shaft shoulders at drive end, relative to location of mechanical seal and bearings, must be adjusted to compensate for the total material removed (see fig 21 or 22 and applicable note, for instruction on adjusting the shaft shoulders).

To lock the bearing at the pump drive end it may be required to introduce an additional spacer to the VDMA 505 that is already used as a standard.

In the event the bearing cover VDMA 360 at drive end interferes with shaft VDMA 210, machining of the bearing cover central bore will be required.

Tab. 9 - RECOMMENDED ORIGINAL CLEARANCES

PUMPS SERIES	PUMPS DESIGN	CLEARANCE each SIDE (mm)	CLEARANCE each IMPELLER (mm)
TRHE 32-20 to 60 TRSE 32	GH - RZ - RA - A3	0,15 ÷ 0,20	0,30 ÷ 0,40
TRHC 40-110 TRHE 40 -110 TRSC 40 TRSE 40	GH - F - RA	0,15 to 0,20	0,30 to 0,40
	A3	0,20 to 0,25	0,40 to 0,50
TRHC 40-140 & 190 TRHE 40-140 & 190 TRSC 50 TRSE 50	GH - F - RA	0,25 to 0,30	0,50 to 0,60
	A3	0,20 to 0,25	0,40 to 0,50
TRHB 50	GH - F - RA	0,20 to 0,25	0,40 to 0,50
	A3	0,30 to 0,35	0,60 to 0,70
TRHC 80 TRSB 100 TRSC 100	GH - F - RA	0,25 to 0,30	0,50 to 0,60
	A3	0,30 to 0,40	0,60 to 0,80
TRHE 100 TRSE 125	GH - F - RA	0,40 to 0,50	0,80 to 1,00
	A3	0,40 to 0,50	0,80 to 1,00
TRVA 65	GH - F - RA	0,15 to 0,20	0,30 to 0,40
	A3	0,20 to 0,30	0,40 to 0,60

**6.1 - TYPICAL SCHEMATICS FOR MACHINING TO RESTORE CLEARANCES
PUMPS SERIES "TRH"**

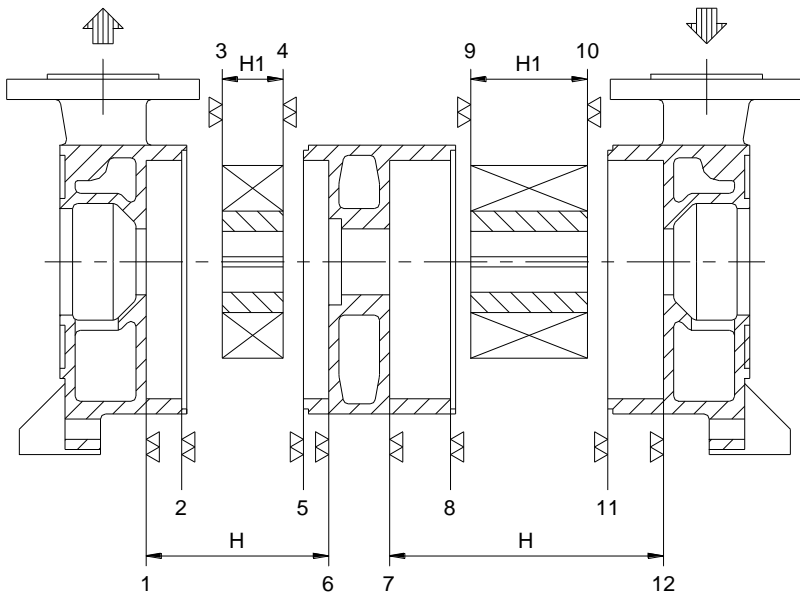

Fig. 13
TRHE 32-20 to 60

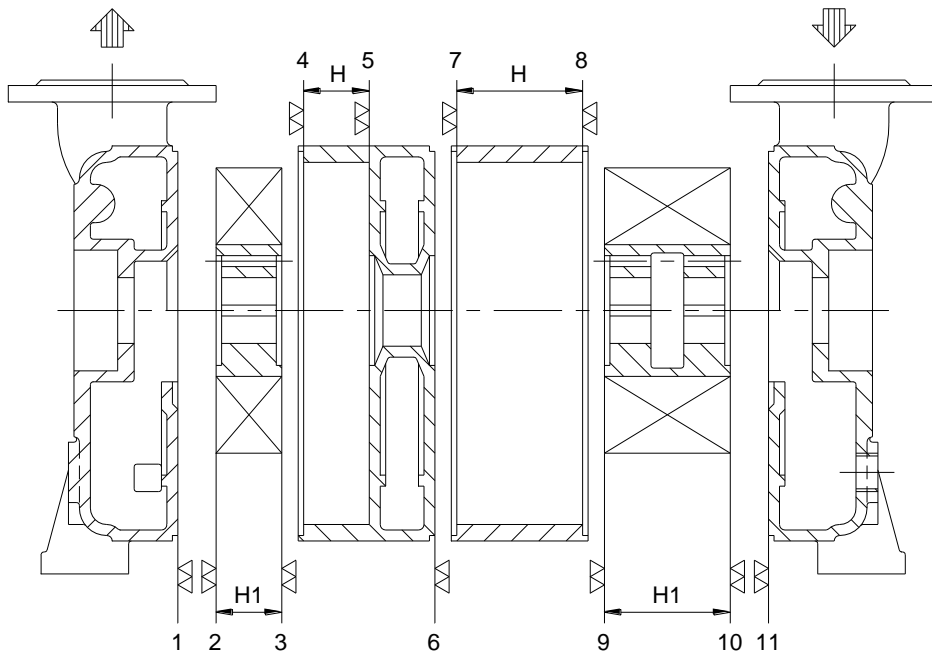

Fig. 14
TRHE 40
TRHB 50/GH - F - RA

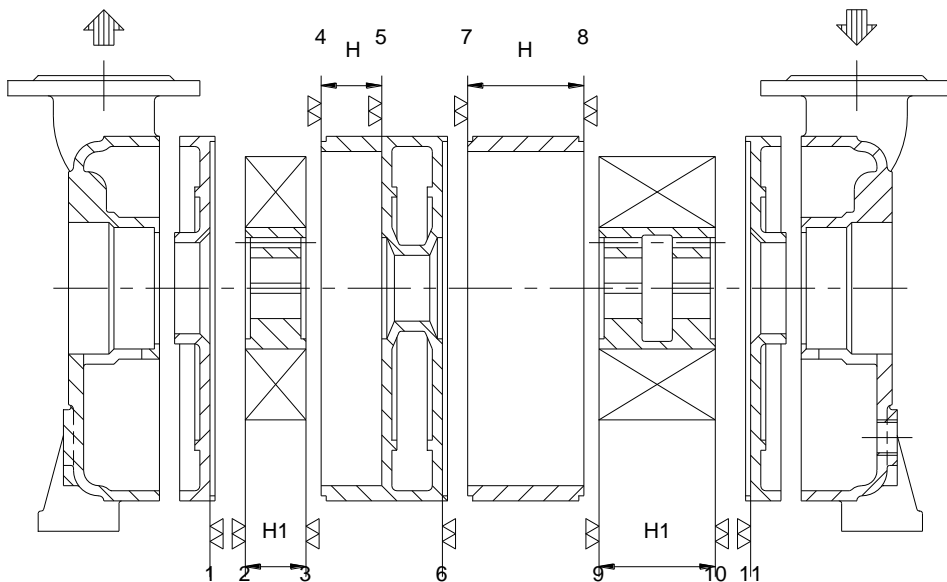

Fig. 15
TRHC 40/GH - F - RA

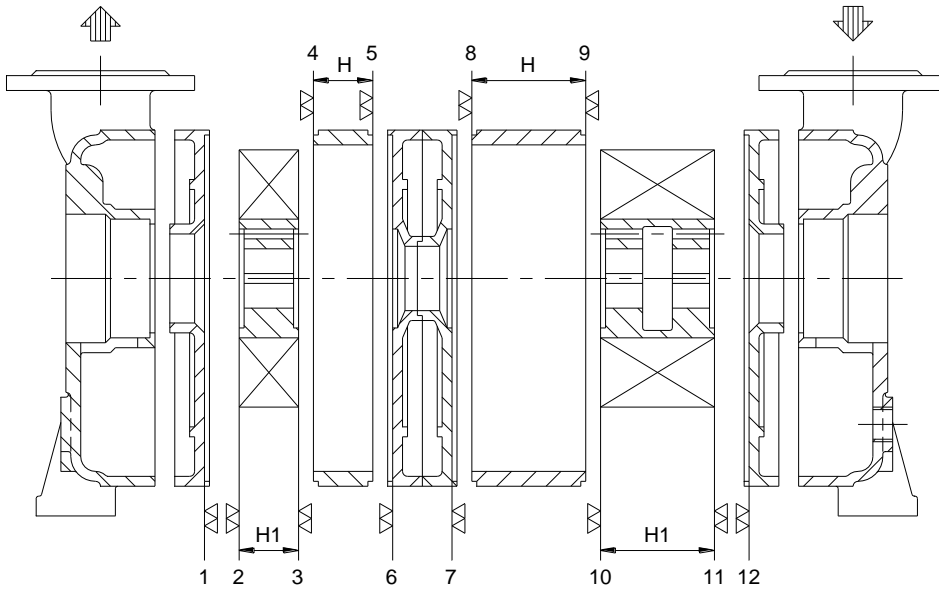

Fig. 16

TRHC 40/B2 - A3
TRHC 80

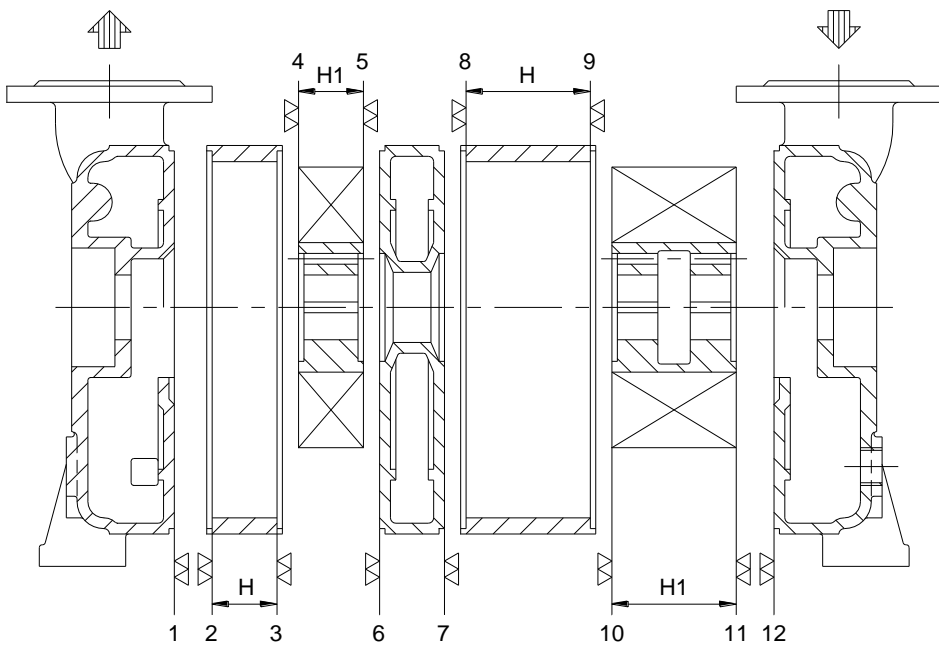

Fig. 17

TRHB 50/B2 - A3
TRHE 100

**6.2 - TYPICAL SCHEMATICS FOR MACHINING TO RESTORE CLEARANCES
PUMPS SERIES "TRS - TRV"**

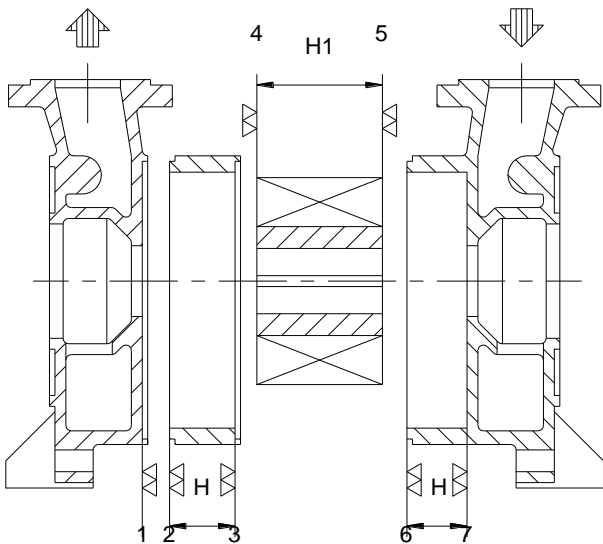

Fig. 18

TRSE 32

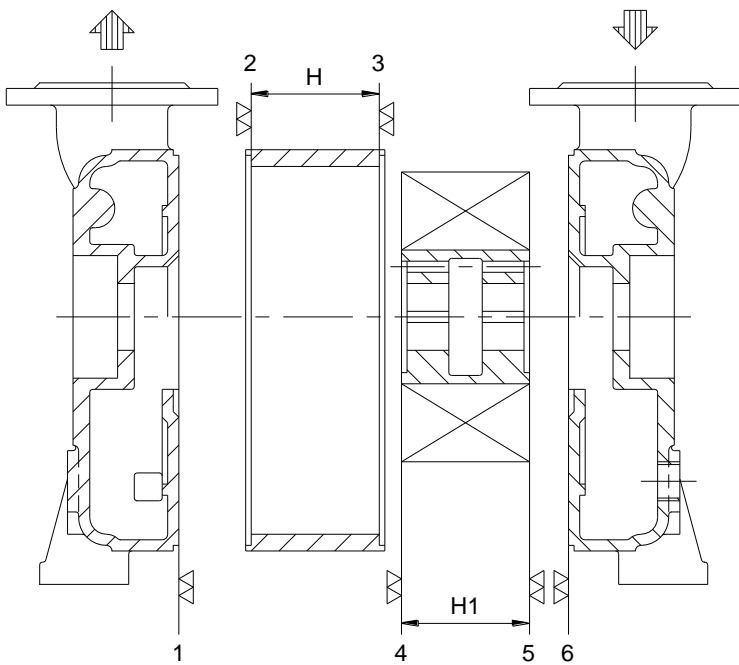

Fig. 19

TRSB 100
TRSE 40 - 50 - 125

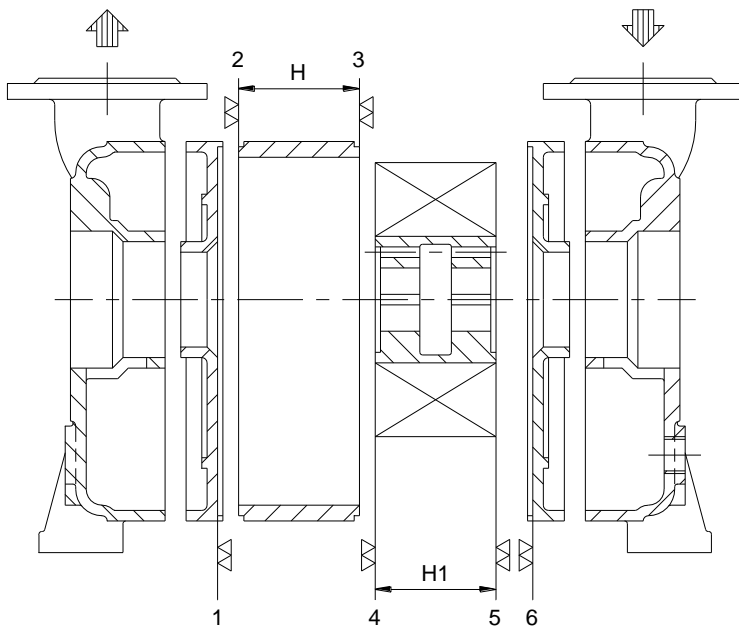

Fig. 20

TRSC 40 - 50 - 100
TRVA 65

Fig. 21
Pumps series "TRH"
(not for series 32 but
applicable to TRHE
32-.../X)

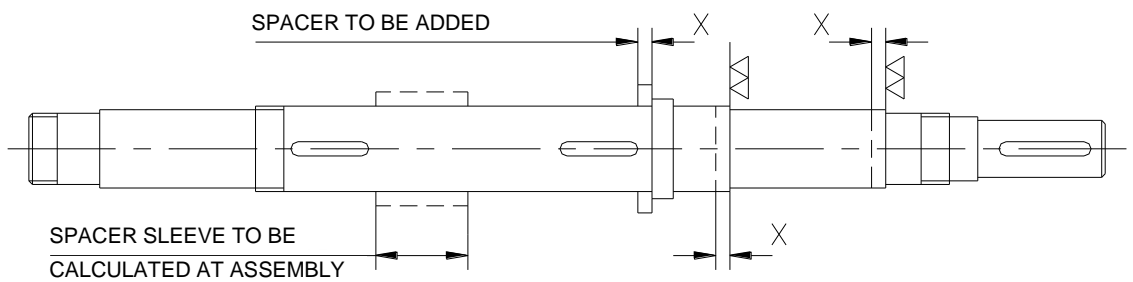
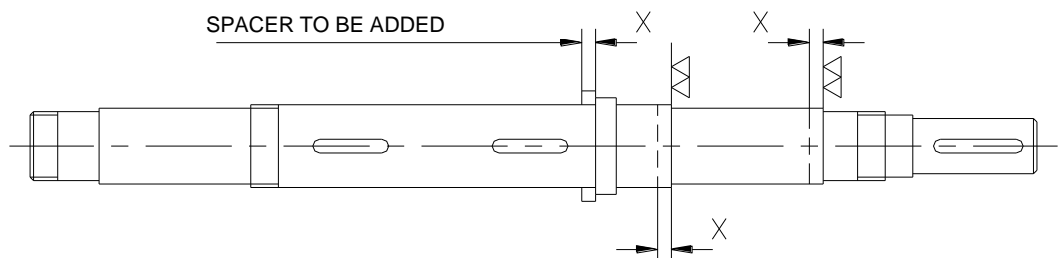

Fig. 22
Pumps series "TRS - TRV"
(not for series 32)



NOTE:
X = Amount of material to be removed equals the sum of material thickness removed from each side of impeller(s) and from all machined port plates. The spacer to be added has a thickness of "X" less the amount of material removed from the last surface (see fig 11 or 12 or 6 or 7).

7 - PUMP ASSEMBLY

Prior to starting the assembly operations, carefully study these instructions to become familiar with the assembly procedures, the sequence of operations and the procurement of the required tools.

WARNING: Depending on pump type, the coupling between impeller hub and shaft may originate clearance or interference. In case of clearance, it is recommended to use a sealant (type "SUPERBOND 320" or similar) to be spread onto the shaft in the area where the impellers will be located while, in case of interference, the impellers will have to be heated to about 180/200°C prior to be shrunk on the shaft and, once they cool down, pressed against the shaft ledge. For more detailed information please consult our Sales Office.

7.1 - PUMPS SERIES" TRHE & TRSE 32" (EXCLUDING CONSTRUCTION TRHE 32-.../X)

Assemble the pumps following the sequences listed on tab. 10 and consulting the sectional drawings in chapter 10 for parts listing and location.

Tab. 10 - ASSEMBLY OF TOTAL PUMP

COMPONENT VDMA No.	Step I											Step II										
	MECHANICAL SEAL	BEARING HOUSING	SHOULDER RING	BEARING	CIRCLIP	ELASTIC RING	BEARING COVER	CIRCLIP	GASKET	DISCHARGE CASING	SCREW	KEY	KEY	2nd STAGE IMPELLER	GASKET	IMPELLER HOUSING	INTERMEDIATE ELEMENT	GASKET	KEY	1st STAGE IMPELLER	SUCTION CASING	TIE-BOLT
PUMPS SERIES	433.1	357	505+ 505.1	320	932	935	365.1	932.3	400.2	107	914.1	940.1	940.2	230.1	400	110	140	400	940.1	230	106	905
TRHE 32-20 & 45	1	1	1+1	1	1	1	1	1	1	1	4		1	1	1		1	1	2	1	1	3
TRHE 32-60	1	1	1+1	1	1	1	1	1	1	1	4	1		1	1		1	1	2	1	1	3
TRSE 32	1	1	1+1	1	1	1	1	1	1	1	4	2			1	1		1		1	1	3

⇒ (to be continued)

COMPONENT VDMA No.	Step III										Step IV		
	MECHANICAL SEAL	GASKET	BEARING HOUSING	SCREW	SHOULDER RING	BEARING	CIRCLIP	BEARING COVER	CIRCLIP	KEY	GASKET	MANIFOLD	BOLT
PUMPS SERIES	433.2	400.2	357	914.1	505	320	932	365	932.3	940	400.8	147	901.8
TRHE 32-20 & 45	1	1	1	4	1	1	1	1	1	1			
TRHE 32-60	1	1	1	4	1	1	1	1	1	1	2	1	4
TRSE 32	1	1	1	4	1	1	1	1	1	1			

- Place the shaft VDMA 210 vertically in a vice, with the drive end pointing down. Moisten the rotating part of the mechanical seal VDMA 433.1 (with soapy water, water, or other but, avoid using oils) and fit it on to the shaft. Lubricate the O-ring of stationary seal part VDMA 433.1 and press the latter into the seal housing VDMA 357. See also chapter 2.
- Clean the two faces of the mechanical seal with a soft tissue. Insert the seal housing on the shaft and hold it pushing the mechanical seal down.
- Slide over the shaft the spacer ring, 2 mm thick, VDMA 505. Insert the spacer ring, 1 mm thick, VDMA 505.1 in the bearing housing. Heat the bearing VDMA 320 and slide it on to the shaft to rest against the shaft shoulder then lock it in place with the snap ring VDMA 932.
- Add the elastic ring VDMA 935 against the face of the bearing. With the help of an extruder, push in place the bearing cover and lock it in with the snap ring VDMA 932.3
- Place the gasket VDMA 400.2 on the seal housing. Slide the shaft and the bearing housing (with gasket) through the discharge casing VDMA 107, secure it in place with the four Allen screws VDMA 914.1. Be sure to locate the seal housing draining hole pointing to the bottom.
- Place the pump in the vertical position resting it on the face of the bearing housing. Insert on the shaft the keys VDMA 940.1 (.2) of impeller VDMA 230 (.1) depending upon the pump series. Place on discharge casing VDMA 107 three (3) small paper spacers having 0.1 mm thickness (impeller spacers that will be discarded as soon as the pump starts rotating). With a brush or similar tool apply the Loctite product "SUPERBOND 320" or similar glue on the shaft area where the 2nd stage impeller will be placed. Slide on the shaft the 2nd stage impeller VDMA 230.1 making sure the impeller blades point to the direction of the pump clockwise rotation as indicated on the schematic's fig 24 or 25 (for special constructions, with counter clockwise rotation, mount the impeller with the blades pointing to the opposite direction).

Place a gasket VDMA 400 on the pump discharge casing.

In the case of single stage pumps (TRSE series), the impeller centre body VDMA 110 should be placed on the discharge casing with a gasket VDMA 400 in between.

In the case of a two-stage pump (TRHE series) fit the intermediate plate VDMA 140, with particular attention as not to damage the radial seal ring VDMA 421 and placing the reference marking pointing to the casing connection, then place a gasket VDMA 400 on the sealing face of the intermediate plate.

For TRHE pump series insert on the shaft the other keys VDMA 940.1 for 1st stage impeller VDMA 230. Place on the face of the intermediate plate VDMA 140 three (3) small paper spacers having 0.1 mm thickness (impeller spacers that will be discarded as soon as the pump starts rotating). With a brush or similar tool apply the Loctite product "SUPERBOND 320" or similar glue on the shaft area where the 1st stage impeller will be placed. Slide on the shaft the 1st stage impeller VDMA 230 making sure the impeller blades point to the same direction as those of the 2nd stage impeller VDMA 230.1. Place the suction casing VDMA 106 on the pump.

- 7) Introduce the three tie-bolts VDMA 905 leaving the nuts finger tight. Place the pump on a flat and horizontal table, align all the pump components and tighten the tie-bolts to 4 kgm (see tab. 13) using a torque wrench.
- 8) Ascertain that the shaft shoulder is 35,5 mm ± 0,5 mm deep relative to the external face of the suction casing VDMA 106 (see fig. 1 and tab. 3). Lubricate the seal rotating part (with water, soapy water, etc. but not oils) and fit it on the shaft. Lubricate the O-ring on the stationary seal and press this part in the seal housing VDMA 357.
NOTE: The seal housing for the drive end side should have threaded holes suitable for the motor lantern, if required. Clean the two seal faces with a soft tissue, place a gasket VDMA 400 on the seal housing and fit this on to the suction casing VDMA 106 with the draining hole located at the bottom.
Lock the assembly with 4 screws VDMA 914.1.
To prevent moving the impellers (from where they have been glued on the shaft) while mounting the bearing VDMA 320 at the drive end, it is recommended to remove the snap ring VDMA 923.3, the bearing cover VDMA 365.1 and the elastic ring VDMA 935. Place the pump in the vertical position resting the shaft on a spacer (not the bearing housing): In this way the movement of the shaft and consequently the impellers will be prevented.
- 9) Introduce on the shaft the 2 mm spacer VDMA 505. Fit the heated bearing VDMA 320 on the shaft until it rests against the spacer. Place the snap ring VDMA 932 on the shaft. Install the bearing cover VDMA 365 securing it with the snap ring VDMA 932.3. Fit the coupling key VDMA 940 on the shaft drive end.
At the end of assembly of the drive end, flip the pump over. Re-install the previously removed elastic ring VDMA 935, bearing cover VDMA 365.1 and the snap ring VDMA 932.
In the event the pump requires the manifold VDMA 147, mount this on to the flanges of the suction casing VDMA 106 and discharge casing VDMA 107, with gaskets VDMA 400.8 between the flanges. Secure with flange bolting VDMA 901.8.
- 10) Rotate the pump shaft by hand to ascertain that it rotates free without internal metal contact.
Test the pump to a hydrostatic pressure of 4 bar to verify that there are no leaks.

7.2 - PUMPS SERIES "TRHE 32-.../X ÷ TRH 40 to 100 - TRS 40 to 125 - TRV 65"

To begin assembling the pump series TRH, find first the length of the spacer sleeve VDMA 521 to be fitted between the two impellers (see fig. 23).

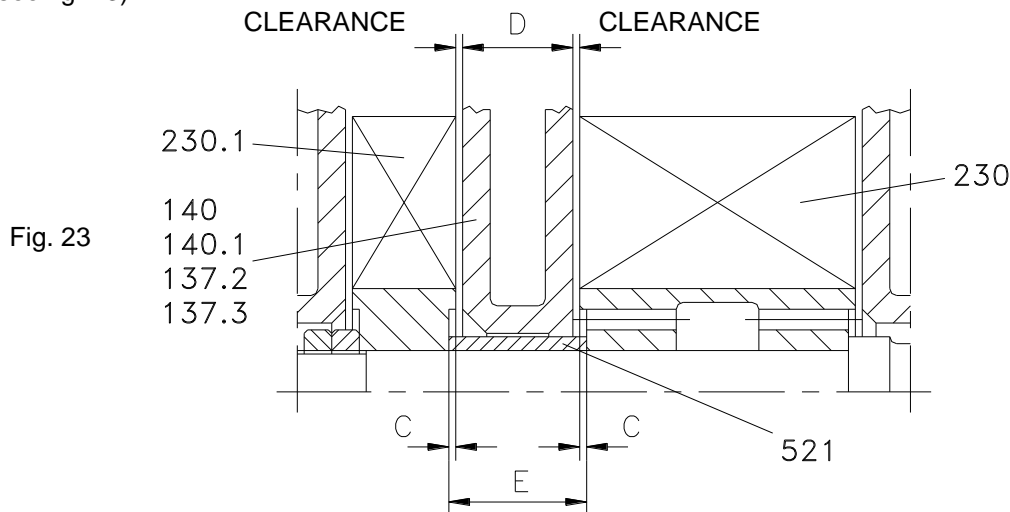

For pump series TRH always measure: The "C" dimensions (when applicable) of the recessed hub for impellers VDMA 230 and 230.1, the width "D" of the intermediate element VDMA 140 or 140.1 or the width of the port plates VDMA 137.2 and 137.3 plus the thickness of the sealing liquid which will be placed between them.

The total sum of "C" dimensions (when applicable) plus the "D" dimension plus the two clearances provided for the type of pump that is being assembled (see tab. 9) will give the required length "E" of the impeller spacer sleeve VDMA 521. Should this be higher the sleeve must be machined, if it is lower, adjusting spacers shall be added.

If adjusting spacers of the correct thickness are not available the different height required could be paired with a correct height of the impeller spacer sleeve VDMA 521.

For all pump's series, place the shaft VDMA 210 with the inserted keys VDMA 940.1 horizontally in a vice, fit the spacer to recover the machining operations carried out on the impellers VDMA 230 (and 230.1 for pumps series TRH) and make sure that they fit perfectly, otherwise provide adjustment.

NOTE for pumps series TRHE 100, TRSB 100, TRSC 100, TRSE 125, TRVA 65.

Before assembling the pump is essential to shrink-fit, after heating to 180/200°C, the impellers VDMA 230 (and 230.1 in case of pumps series TRH) on the shaft VDMA 210 and blocking them, after cooling, with the nuts VDMA 922 or 922.1.

WARNING: Before inserting the impellers on the shaft, note that the direction of the blades for the pumps with c.w. rotation should be as per drawings on fig. 24 or 25 (for the c.c.w. rotation, reverse the orientation of the impeller blades).

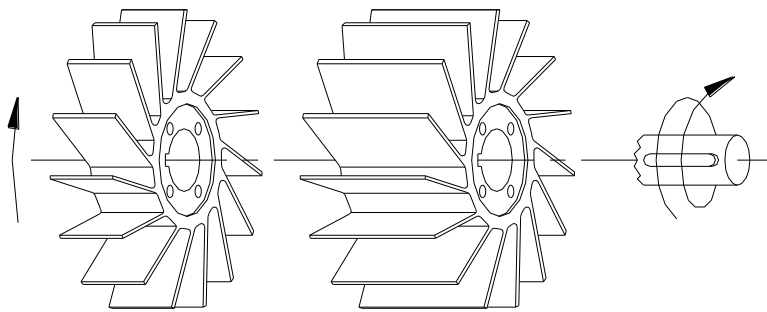

Fig. 24 - Pumps series TRH

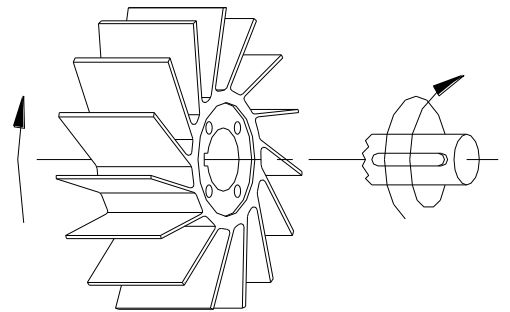

Fig. 25 - Pumps series TRS - TRV

Whenever required, liquid compound to be used as gasket for metallic surfaces should be procured.

The sealing liquid commonly used and available from our stock is "LOCTITE 510 **Superrapide**" and is available in 50 ml cans.

NOTE: It is recommended to carry out a **preliminary assembly** without liquid gasket, of those pump parts included between the two casings to verify the clearances obtained are adequate.

The information given below is for reference purpose, for more detailed and precise information (on gaskets, small items and quantities) see tab. 11 or 12.

For pump series TRH, remove the smaller impeller VDMA 230.1 and its key, insert the impeller spacer sleeve VDMA 521, the intermediate element VDMA 140 or 140.1 or the port plates VDMA 137.2 and 137.3 (WARNING: lock them with three clamps to prevent them from separating), insert the key and place the impeller VDMA 230.1, lock the assembly with the impeller nut(s) VDMA 922 or 922.1 (see fig. 26 or 27).

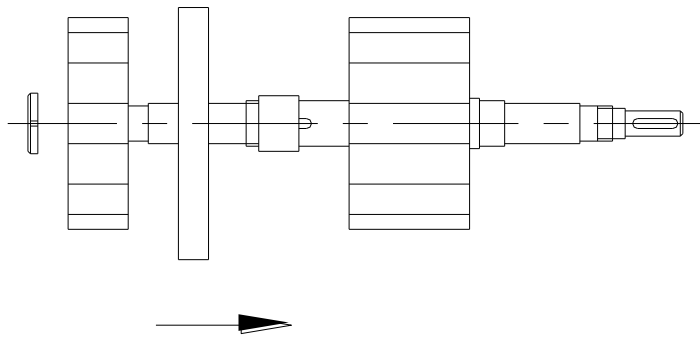

Fig. 26 - Pumps series TRH (step I)

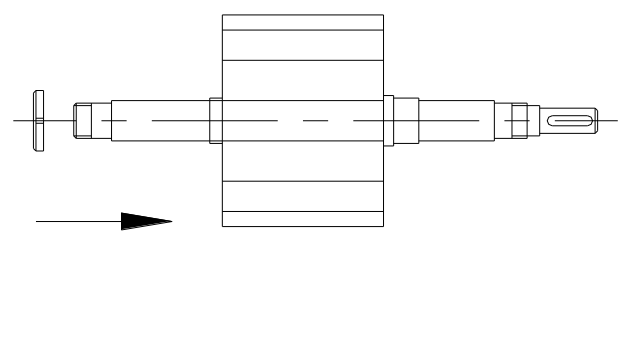

Fig. 27 - Pumps series TRS - TRV (step I)

Place the suction casing VDMA 106 (complete with port plate VDMA 137.1 if required) in the horizontal position, resting on a stand similar to that shown on fig. 28 to 31 (section of heavy-duty pipe or similar stand).

Assemble the impeller casing VDMA 110 (or, when provided, the two impeller casings that form the first stage) with the reference's markings on the casting, in line with the axis of the inlet casing.

Remove the shaft from the vice together with the impeller(s) and the intermediate plate(s), insert it into the suction casing, using (for heavier assemblies) a threaded hook screwed on the non-drive end of the shaft, see fig.28 or 30.

Continue the assembly operations following the instructions given on fig. 29 or 31 and tab. 11 or 12: to help with the identification and the location of each component, see also the sectional drawings on chapter 10.

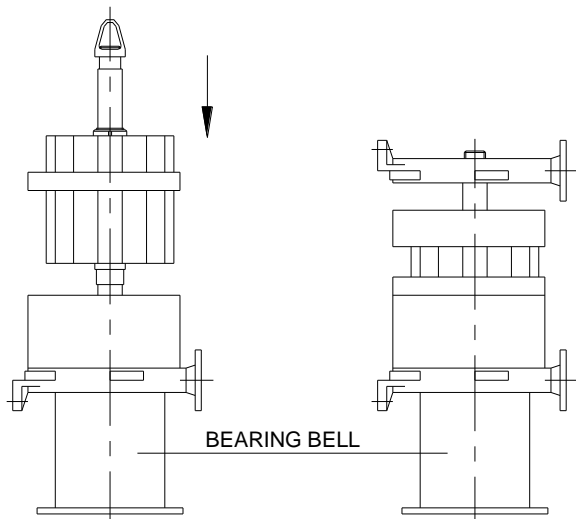

Fig. 28 and 29 - Pumps series TRH (step II & III)

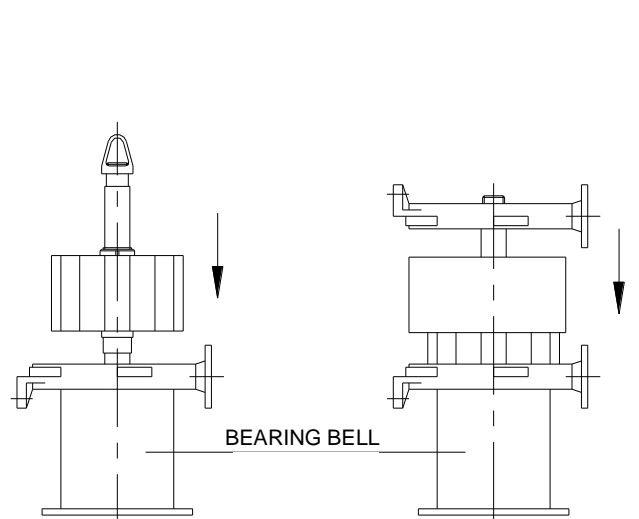

Fig. 30 and 31 - Pumps series TRS - TRV (step II & III)

Tab. 11 - ASSEMBLY OF TOTAL PUMP - PUMPS SERIES "TRH"

COMPONENT VDMA No.	Step I										Step II						⇒ to be continued
	1st STAGE IMPELLER	SPACER SLEEVE	INTERMEDIAT E ELEMENT	PORT PLATE	PIN	PORT PLATE	2nd STAGE IMPELLER	SPACER SLEEVE	NUT		SUCTION CASING	PIN	PORT PLATE	GASKET	IMPELLER CASING	GASKET	
PUMPS SERIES	230	521	140	140.1	137.2	561	137.3	230.1	525	922	922.1	106	561	137.1	400	110	400
TRHC 40-110/ GH - F - RA	1	1	1					1	1		1	1	1	1	1	1	1
TRHC 40-110/ B2 - A3	1	1			1	1	1	1	1	2		1	1	1	1	1	1
TRHE 40-110	1	1	1					1		2		1			1	1	1
TRHC 40- 140 & 190/ GH - F - RA	1	1	1					1	1		1	1	1	1	1	1	1
TRHC 40- 140 & 190/ B2 - A3	1	1			1	1	1	1	1	2		1	1	1	1	1	1
TRHE 40- 140 & 190	1	1	1					1		2		1			1	1	1
TRHB 50/ GH - F - RA	1	1		1				1			1	1			1	1	1
TRHB 50/ B2 - A3	1	1	1					1		2		1			1	1	1
TRHC 80	1	1			1	1	1	1		1		1	1	1	1	1	1
TRHE 100	1	1	1					1		2		1			1	2	2

(continuation) ⇒

COMPONENT VDMA No.	Step III							Step IV		
	GASKET	IMPELLER CASING	GASKET	PORT PLATE	PIN	DISCHARGE CASING	TIE-BOLT	GASKET	MANIFOLD	BOLT
PUMPS SERIES	400	110.1	400	137.4	561	107	905	400.8	147	901.8
TRHC 40-110/ GH - F - RA			1	1	1	1	4			
TRHC 40-110/ B2 - A3	1	1	1	1	1	1	4			
TRHE 40-110			1			1	4			
TRHC 40- 140 & 190/ GH - F - RA			1	1	1	1	4	2	1	8
TRHC 40- 140 & 190/ B2 - A3	1	1	1	1	1	1	4	2	1	8
TRHE 40- 140 & 190			1			1	4	2	1	8
TRHB 50/ GH - F - RA			1			1	5	2	1	8
TRHB 50/ B2 - A3	1	1	1			1	5	2	1	8
TRHC 80	1	1	1	1	1	1	5	2	1	8
TRHE 100	1	1	1			1	7	2	1	16

Tab. 12 - ASSEMBLY OF TOTAL PUMP - PUMPS SERIES "TRS - TRV"

COMPONENT VDMA No.	Step I				Step II				Step III						Step IV			
	IMPELLER	SPACER SLEEVE	NUT		SUCTION CASING	PIN	PORT PLATE	GASKET	IMPELLER CASING	GASKET	PORT PLATE	PIN	DISCHARGE CASING	TIE-BOLT	GASKET	MANIFOLD	BOLT	
PUMPS SERIES	230	525	922	922.1	106	561	137.1	400	110	110.1	400	137.4	561	107	905	400.8	147	901.8
TRSC 4055- 100	1	1		1	1	1	1	1	1		1	1	1	4				
TRSC 40-150	1	1		1	1	1	1	1	1		1	1	1	4	2	1	8	
TRSE 40	1		2		1			1	1		1		1	4				
TRSC 50	1	1		1	1	1	1	1	1		1	1	1	4	4	2	16	
TRSE 50	1		2		1			1	1		1		1	4	4	2	16	
TRSB 100	1		2		1			1	1	1	2		1	7	4	2	16	
TRSC 100	1		1		1	1	1	1	1		1	1	1	5	4	2	16	
TRSE 125	1		2		1			1	1	1	2		1	7	4	2	32	
TRVA 65	1		2		1	1	1		1			1	1	5	4	2	16	

Now that the discharge casing VDMA 107 is in place, insert the tie-bolts VDMA 905 tightening them lightly, place the pump in the horizontal position on a flat table and align the casings.

Then tighten the tie-bolts with a torque wrench (see tab. 13 for the required load).

Make sure that the impeller clearances within the housing are correct. Check this by measuring the shaft travel when pushed first to one direction and then to the other and dividing this value by 2 (see tab. 9).

If the clearance is not at least 0,15 mm each side, disassemble the pump and check all components until the error is found; the required clearances must be rebuilt as given in chapter 6, then assemble the pump again following the instructions given above.

Now assemble the mechanical seals (see chapter 2) and the bearings (see chapter 3) as it is indicated on fig. 32 or 33. Assemble the manifold(s) VDMA 147 (when provided) with the corresponding gaskets VDMA 400.8 and bolts VDMA 901.8.

Rotate the shaft by hand making certain that there is no internal metal to metal contact and the rotor rotates freely.

Test the pump to a hydrostatic pressure of 4 bar to verify that there are no leaks.

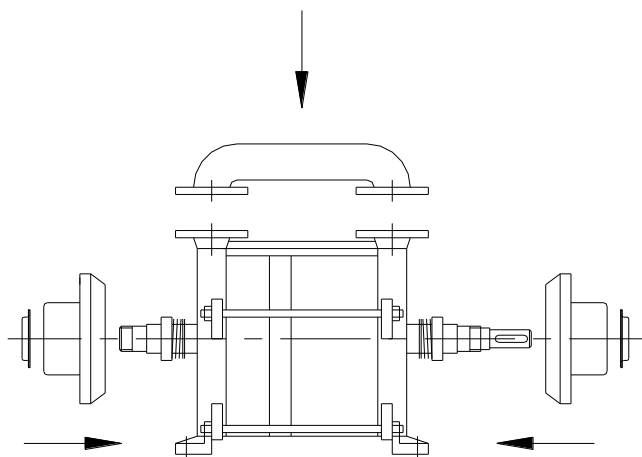

Fig. 32 - Pumps series TRH (step IV)

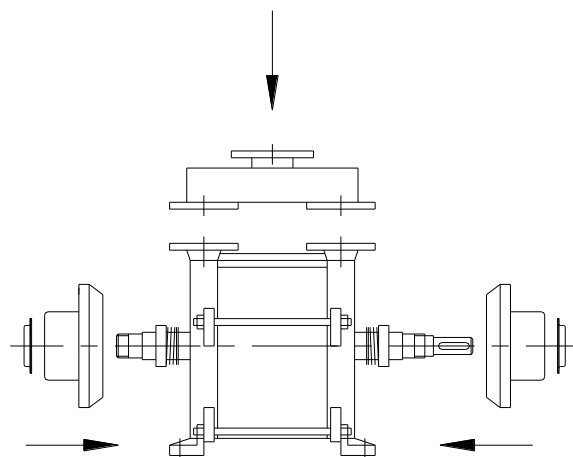
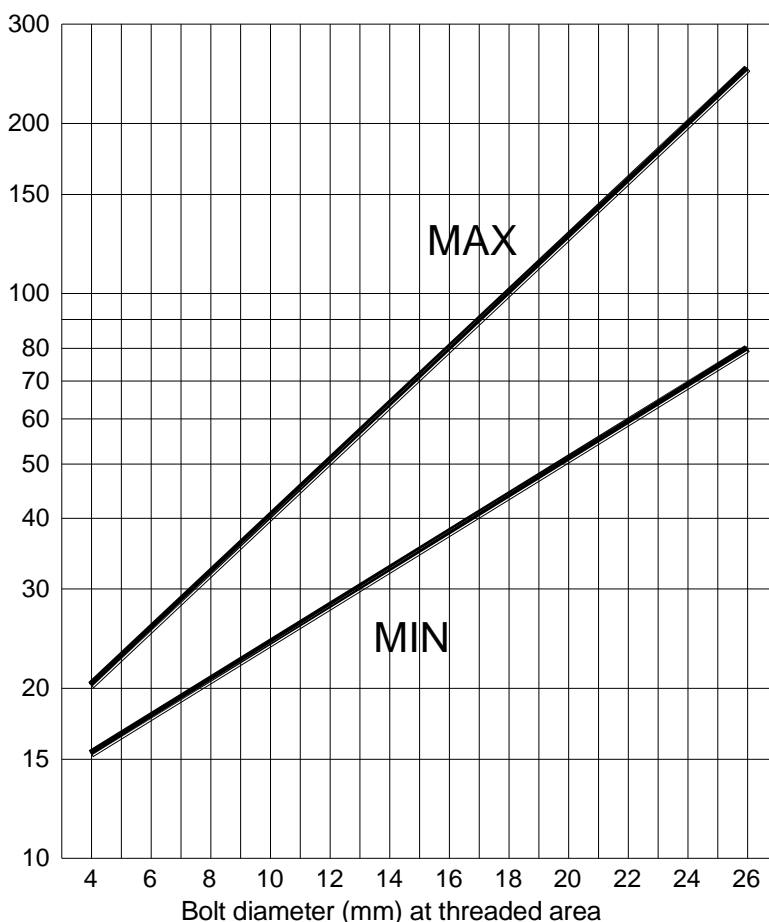

Fig. 33 - Pumps series TRS - TRV (step IV)

Fig. 34
TORQUE VALUES FOR VARIOUS BOLT SIZES

Torque values (Nm)



Tab. 13
TIE-BOLTS
TORQUE VALUES

PUMPS SERIES	TIE-BOLTS		TORQUE VALUES	
	Ø	Quantity	kgm	Nm
TRHE 32-20 to 60 TRSE 32	12	3	4	39,2
TRHE 40-110 TRSE 40			5	49
TRHC 40 TRHE 40-140 & 190 TRSC 40 TRSC 50 TRSE 50	14	4	6	58,8
TRVA 65 TRHB 50			5	6,5
TRHC 80 TRSC 100 TRSB 100	16			8
TRHE 100 TRSE 125			18	7

8 - RECOMMENDED SPARE PARTS

When ordering the pump, it is good practice to also order the necessary spare parts, especially when there are no stand-by pumps in the installation. This will minimise unnecessary down times in the event of pump failures or routine maintenance.

It is therefore, recommended to stock the following spare parts for each pump size:

- 1 Impeller set
- 1 Port plates set
- 1 Complete shaft assembly
- 1 Bearing set
- 1 Mechanical seal set
- 2 Gasket sets
- 1 Gasket sealing liquid
- 1 Bearing spacer ring set
- 1 Coupling insert set

For better parts management, the VDMA 24296 standards suggest to stock the number of parts as a function of the number of pumps being used in the plant.

On the pump nameplate are printed pump model, year of manufacture and pump serial number. When ordering spare parts always provide this information.

Pump type, parts item number (VDMA) and description, as per the parts list on chapter 9 and pump sectional drawings on chapter 10, is useful information that helps to supply correct spare parts for your pump.

We recommend the use of original parts: in case of deviation, POMPETRAVAINI declines any responsibility for eventual damages caused by non-original spare parts.

9 - PARTS LIST

VDMA No.	COMPONENT
106	Suction casing
107	Discharge casing
110...	Impeller casing
137...	Port plate
140...	Intermediate element
147	Manifold
180.5	Valve plate
210	Shaft
230...	Impeller
320	Ball bearing
357	Bearing and mechanical seal housing
360...	Bearing cover
365...	Bearing cover
400...	Gasket
400.9	Flat valve
421...	Radial seal ring
433...	Mechanical seal
461.1	Gland packing
485...	Mechanical seal ring
505...	Shoulder ring
521	Impeller spacer sleeve
525	Spacer sleeve
554.3	Lock washer
554...	Washer

VDMA No.	COMPONENT
542	Seal bush
561	Cylinder pin
636	Greaser
672	Anti-cavitation valve
701	Pipe
723...	Companion flange
731...	Fitting
734	Nipple
735	Nipple
901...	Screw
901.8	Bolt
902...	Stud
903...	Plug
904.1	Grub screw
905	Tie-bolt
914...	Screw
922...	Nut
923	Nut
932...	Circlip
935	Elastic ring
940...	Key
Z	Liquid supply inlet

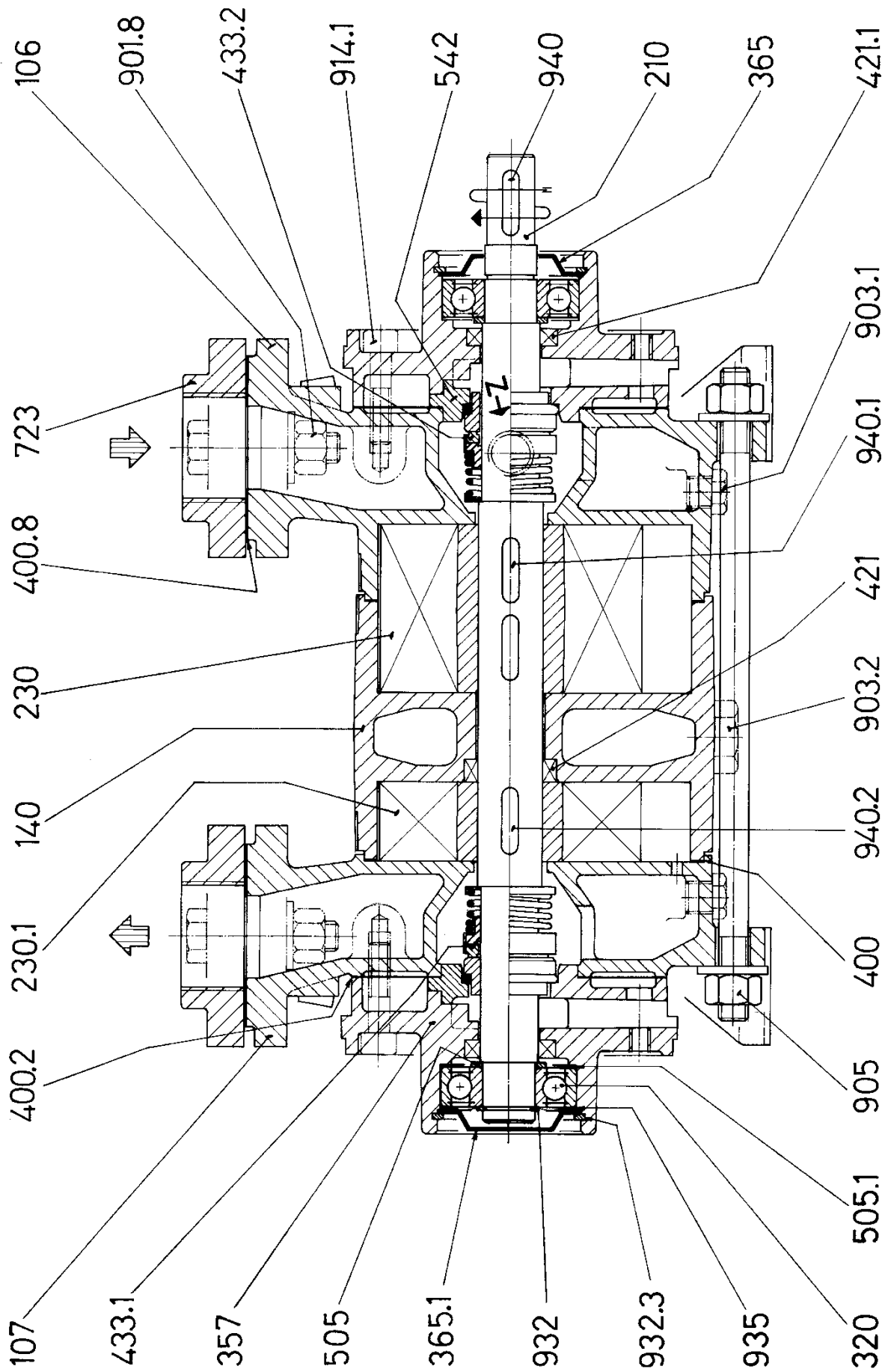

TRHE 32-20 & 45

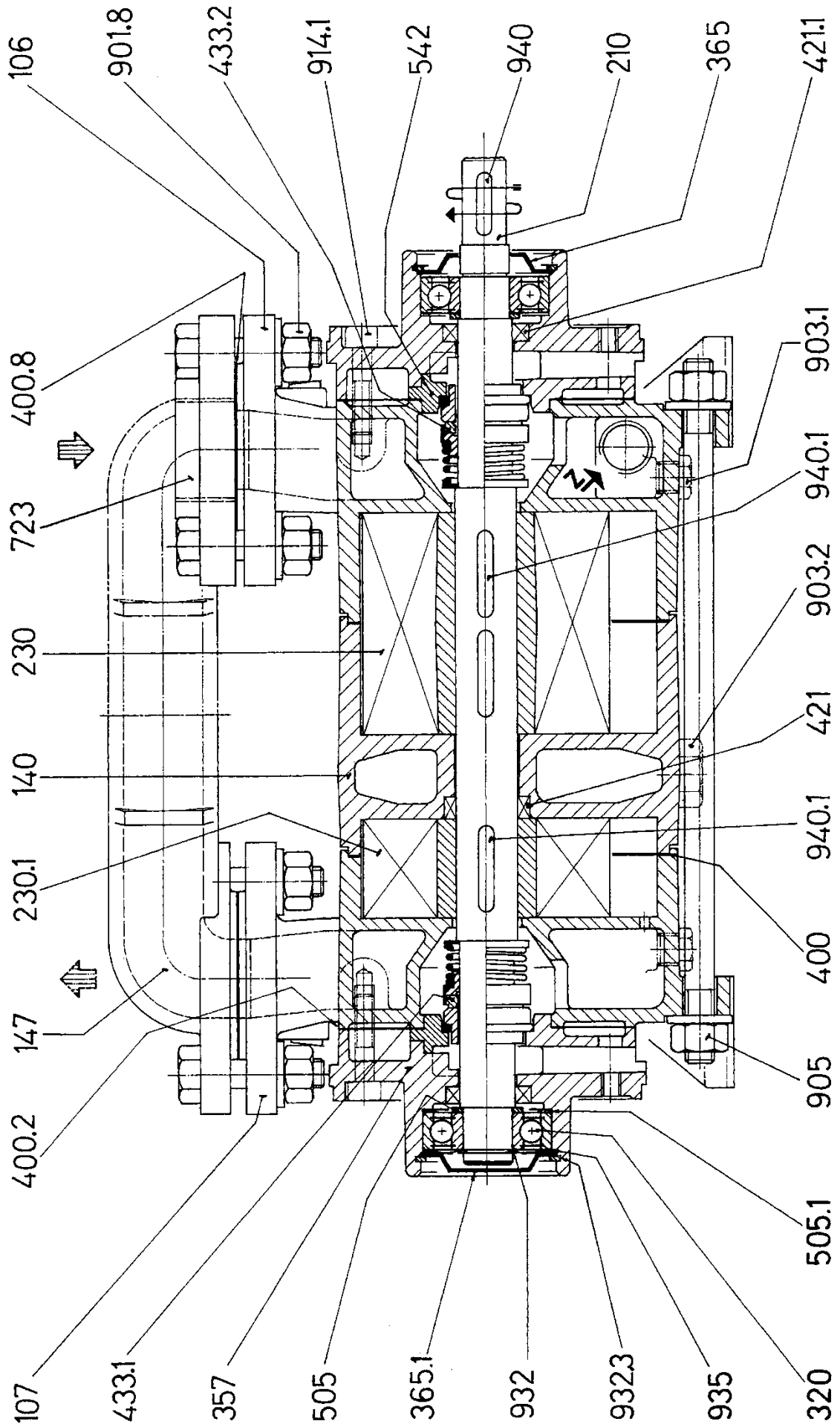

TRHE 32-60

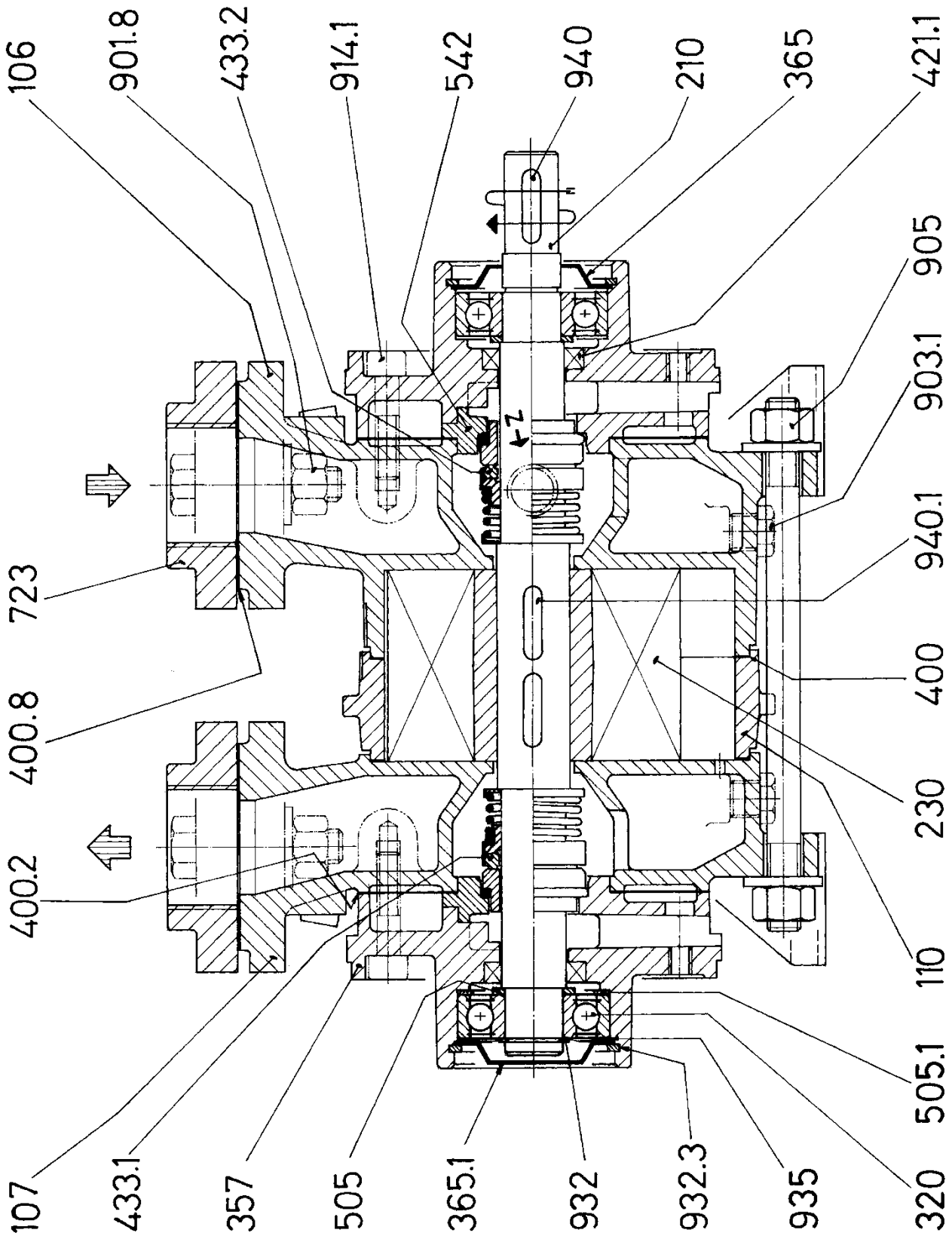

TRSE 32

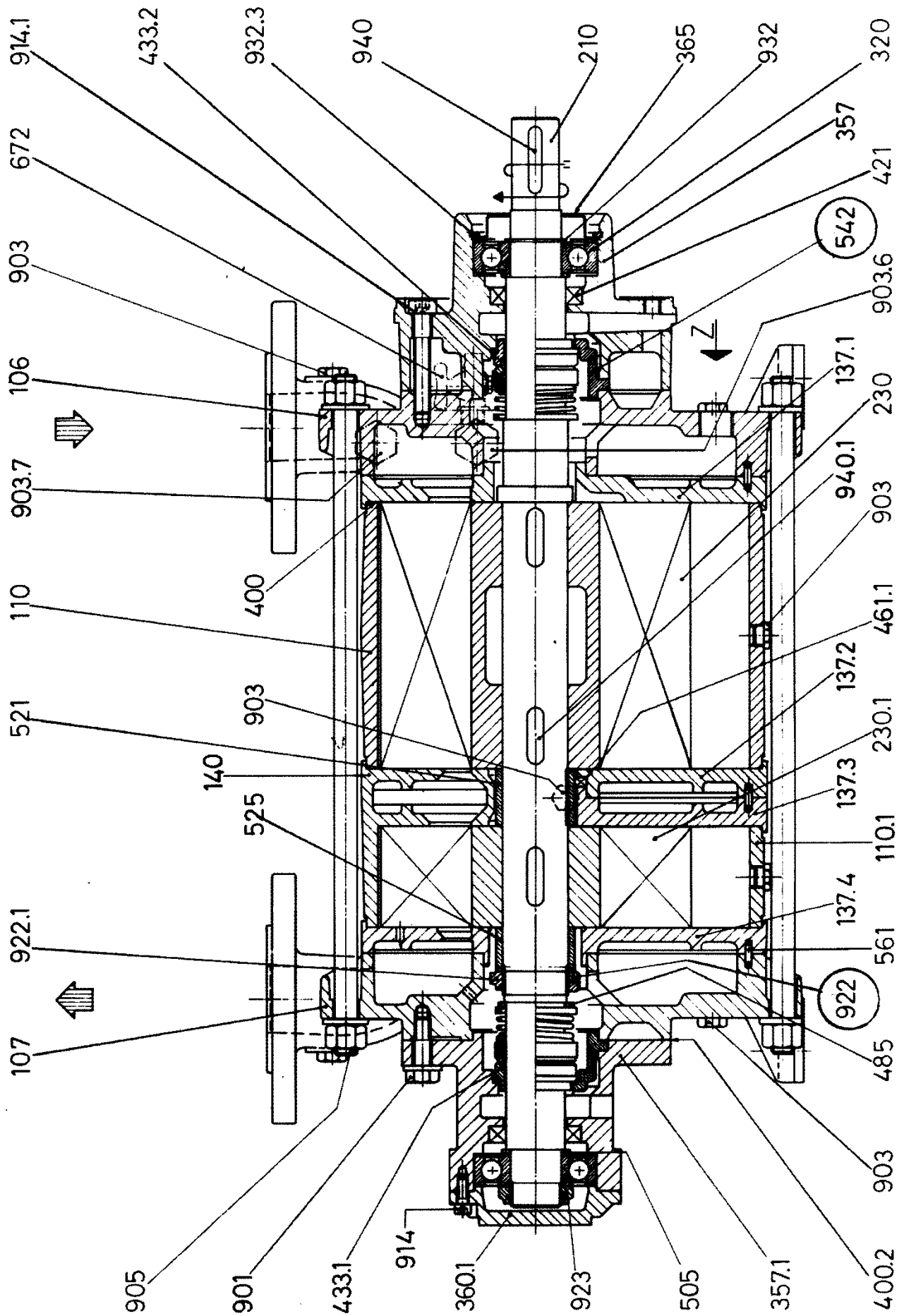

TRHC 40-110

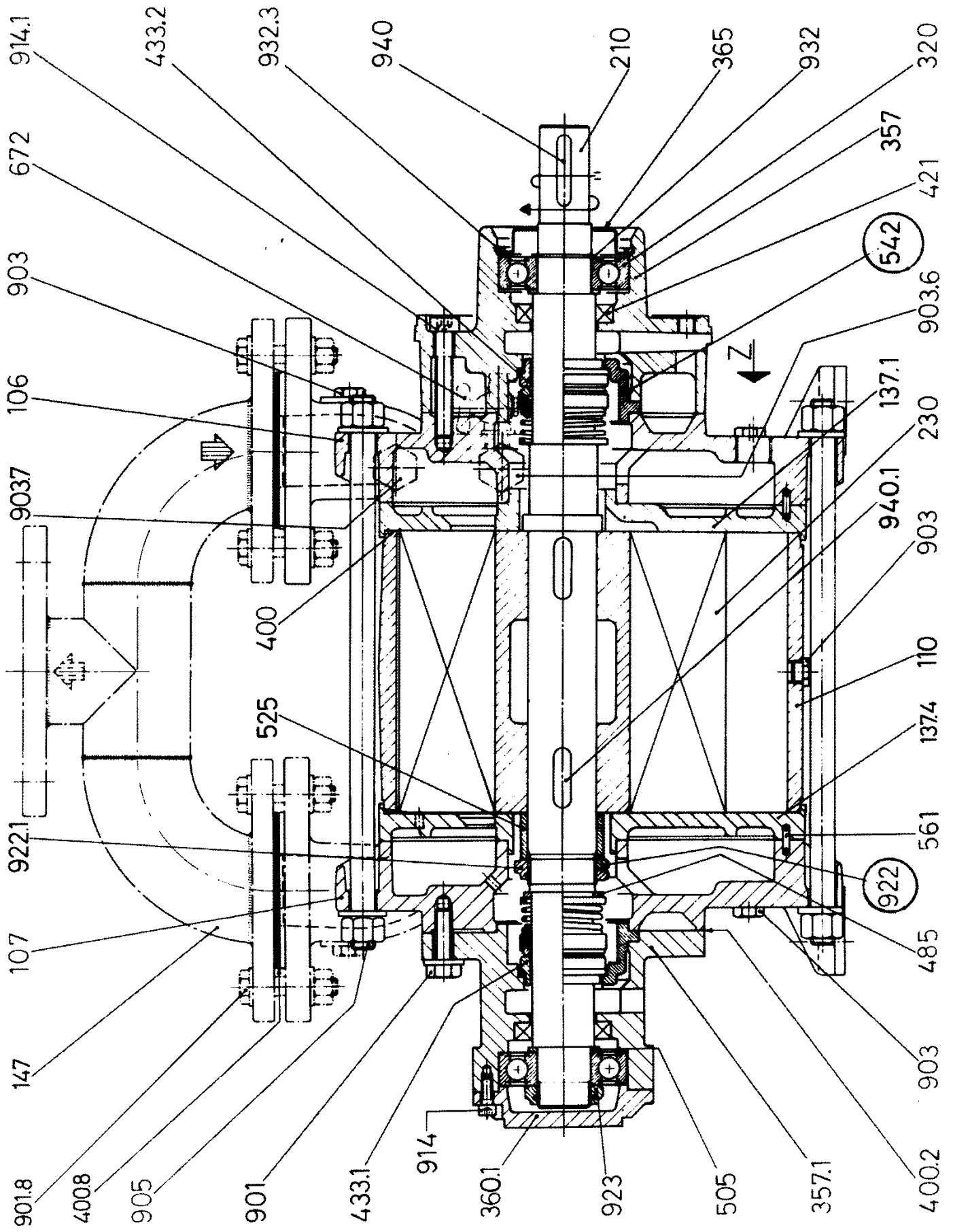

TRSC 40

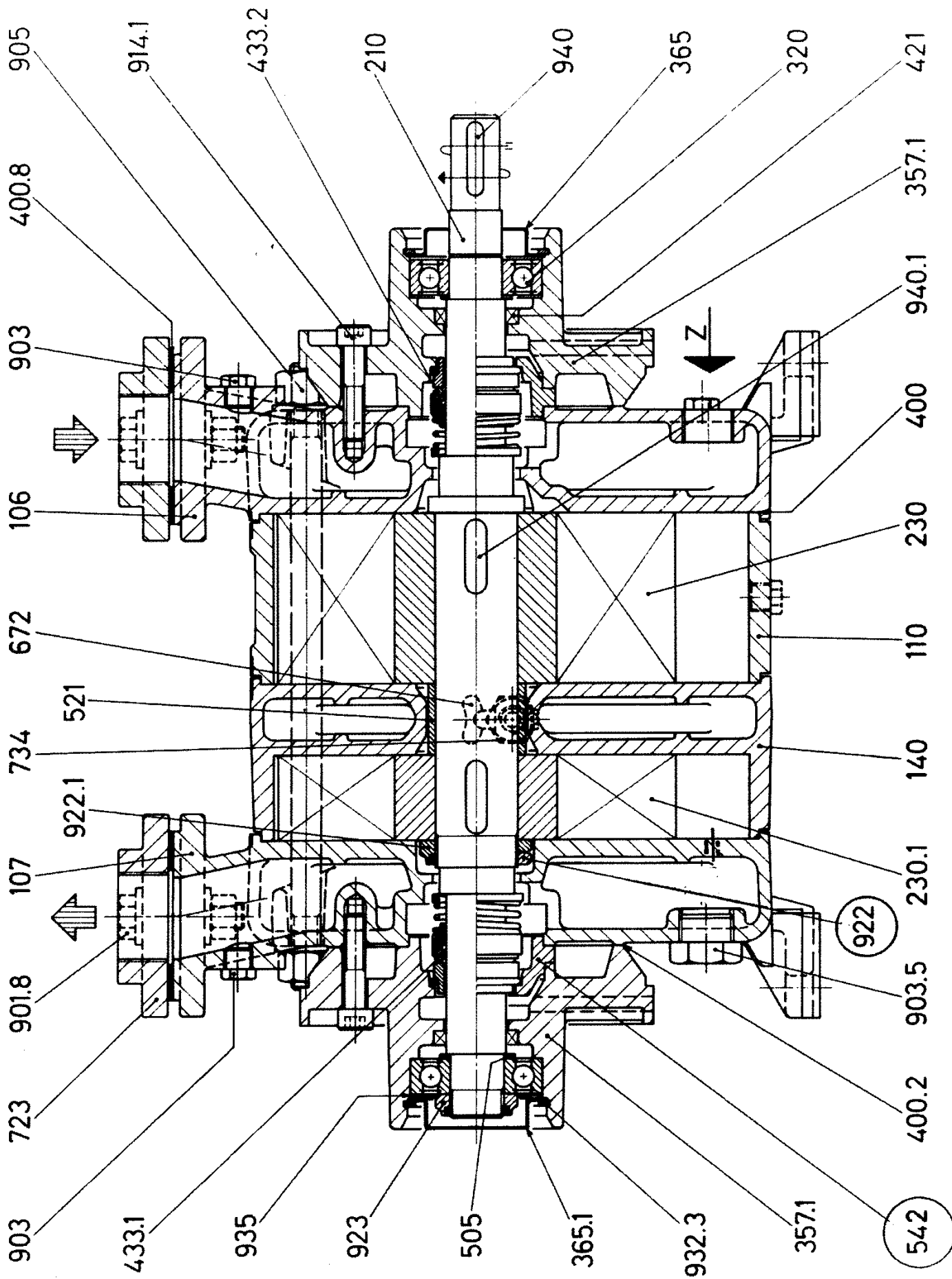

TRHE 40-110

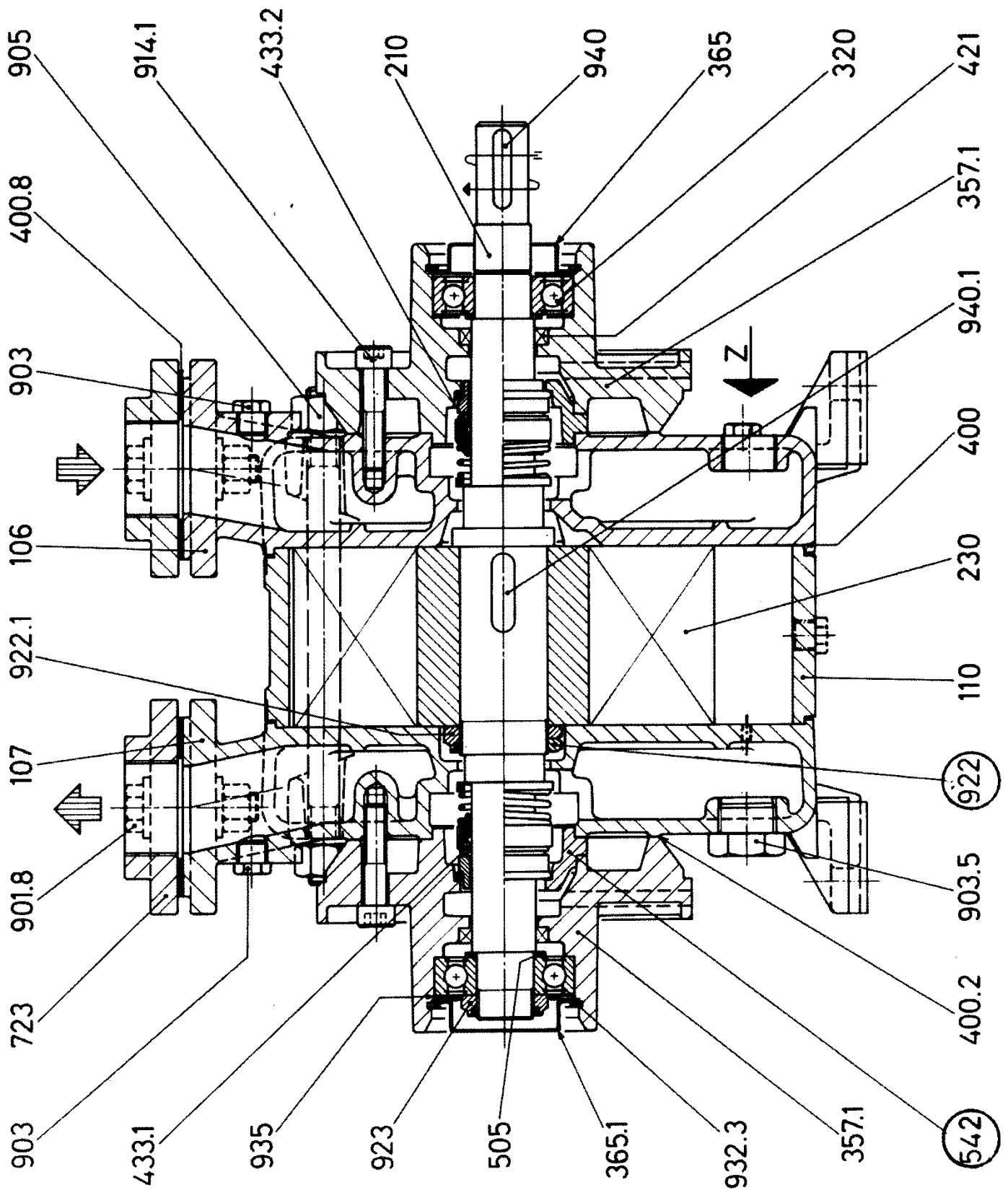

TRSE 40

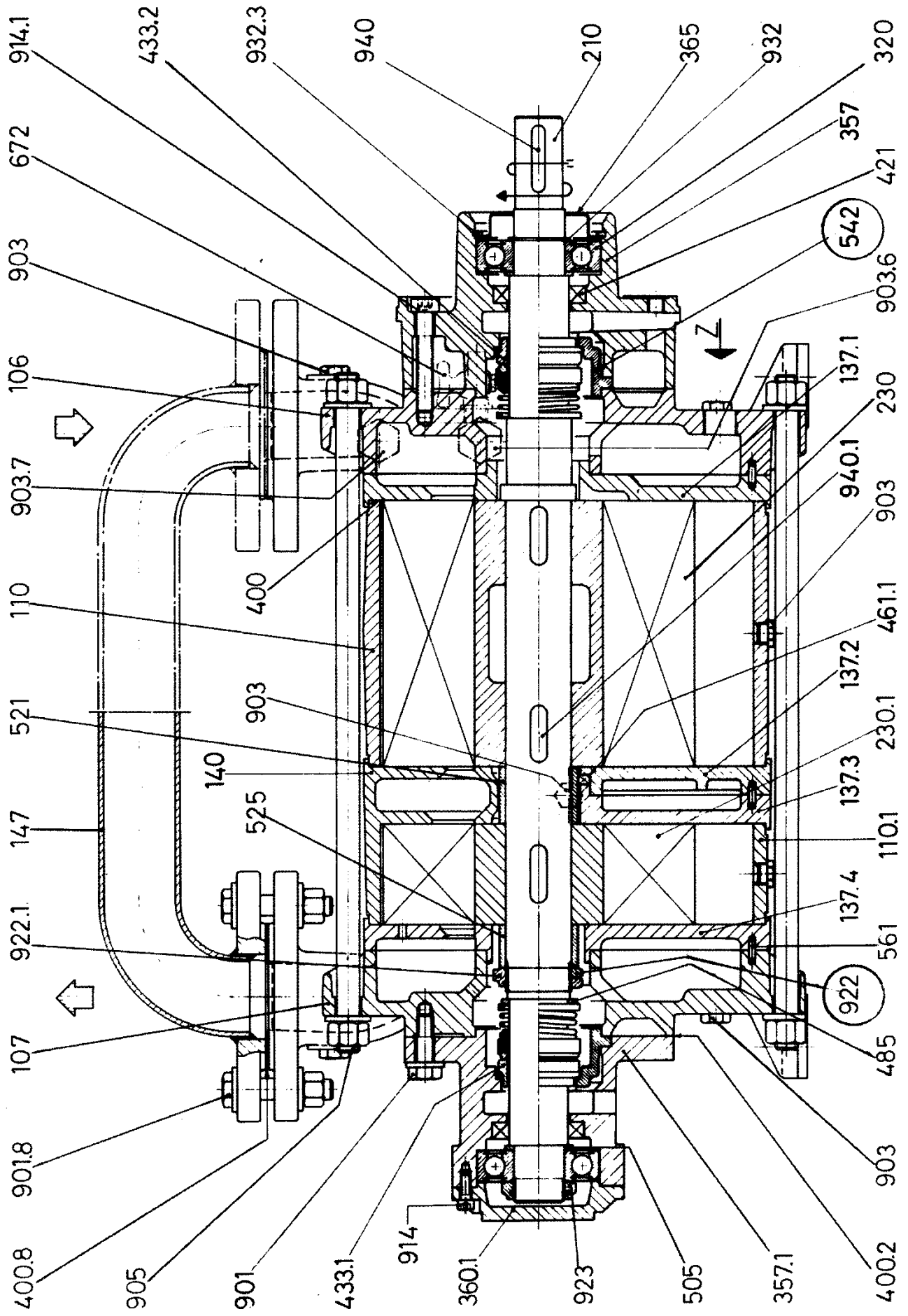

TRHC 40-140 & 190

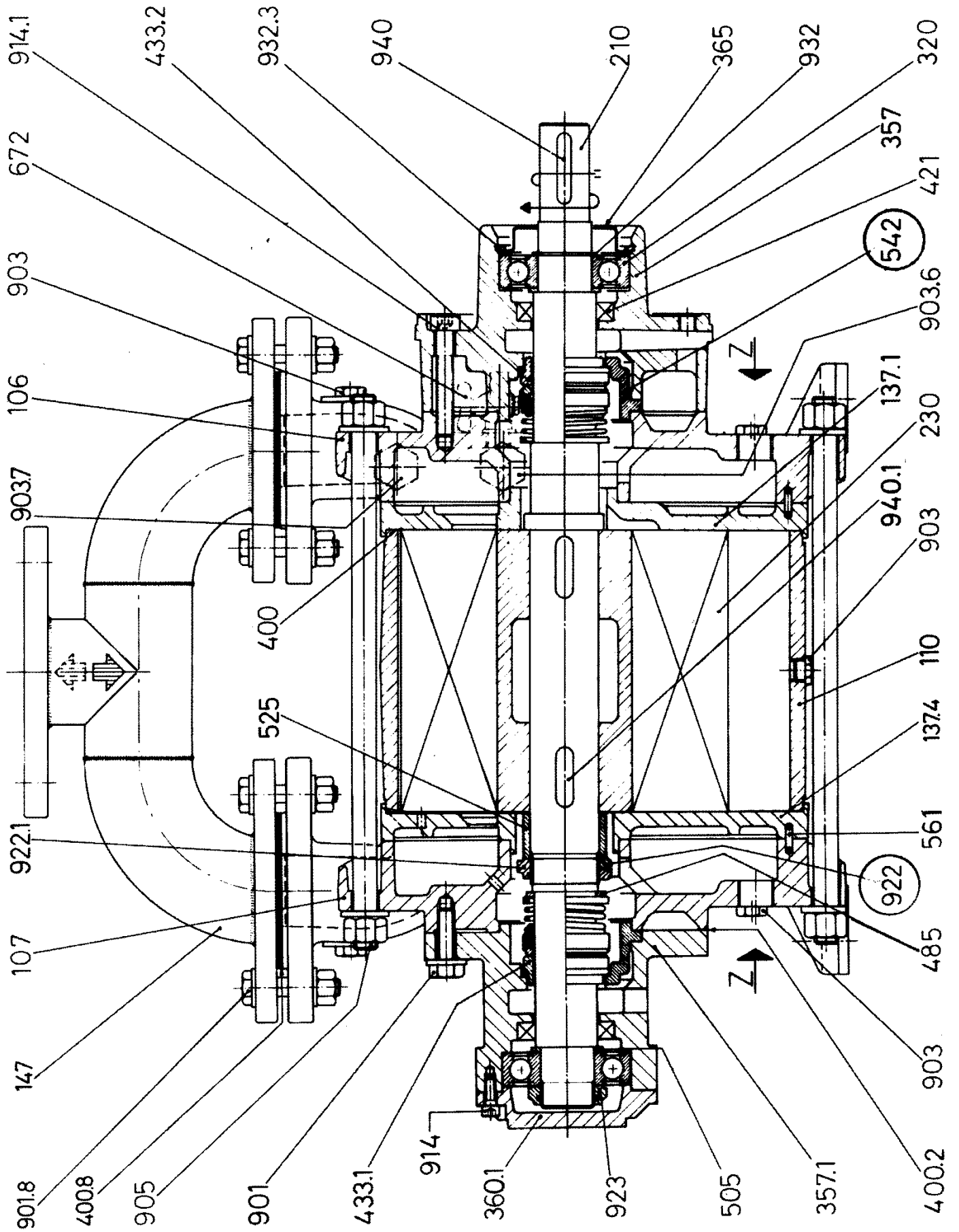

TRSC 50

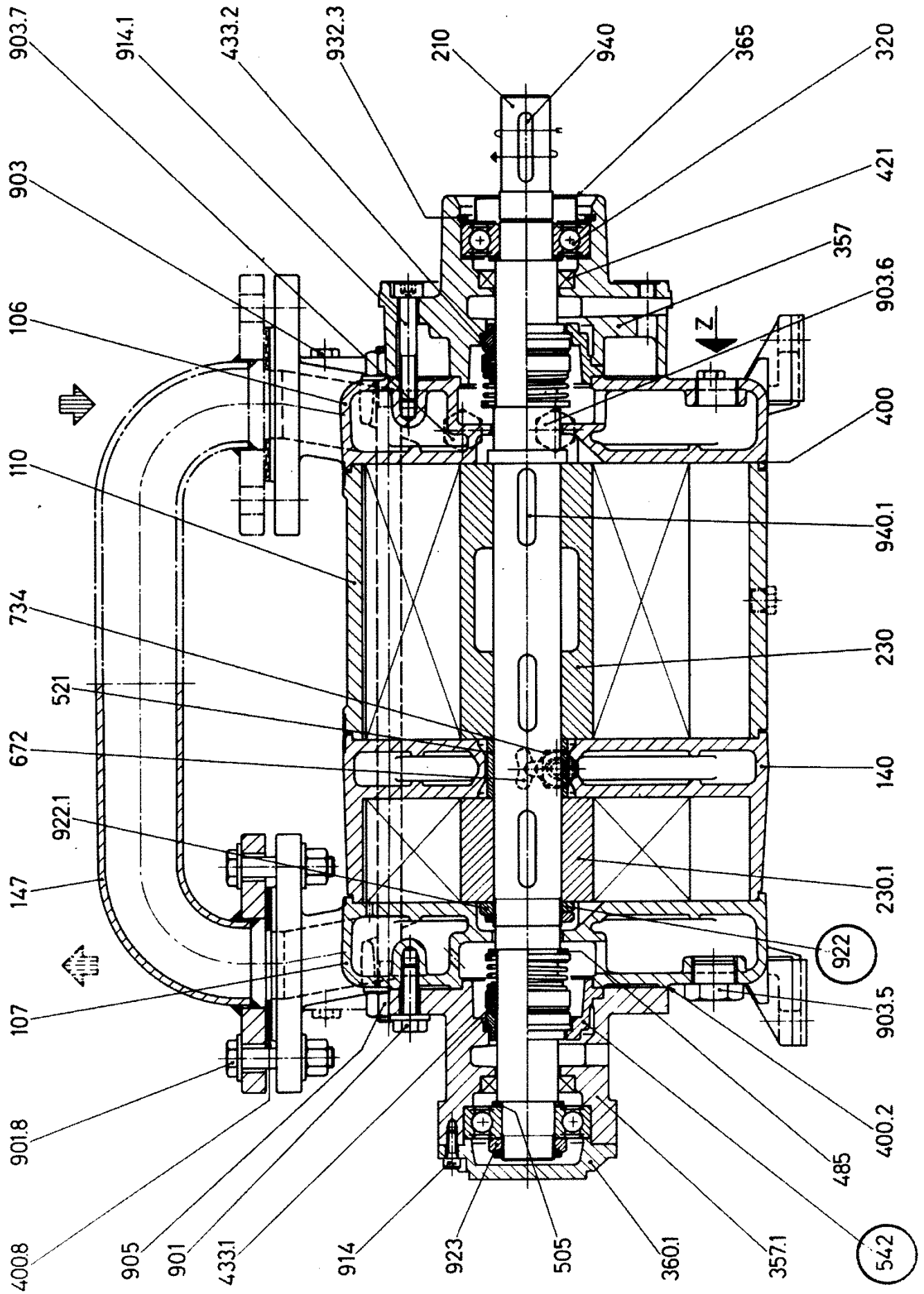

TRHE 40-140 & 190

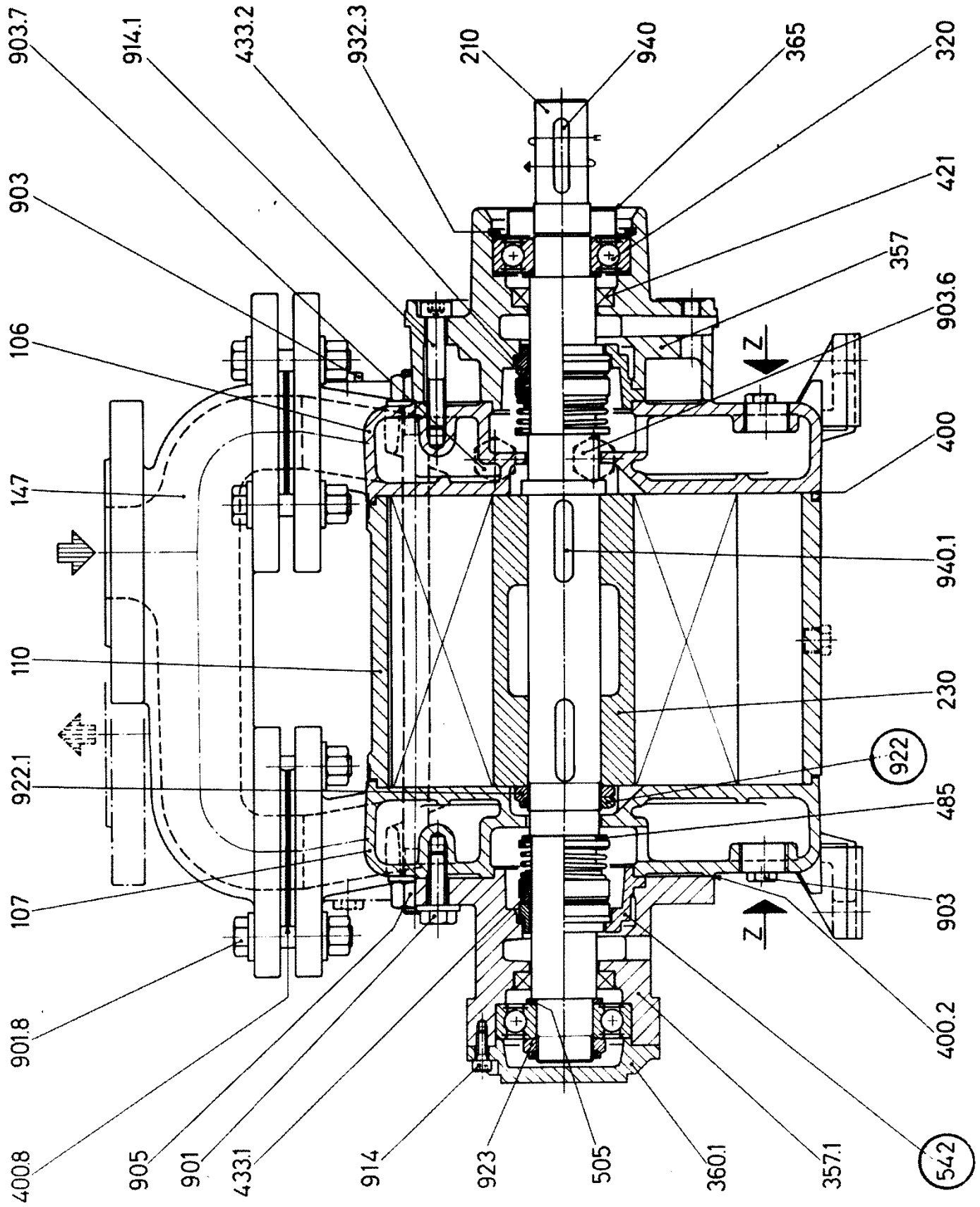

TRSE 50

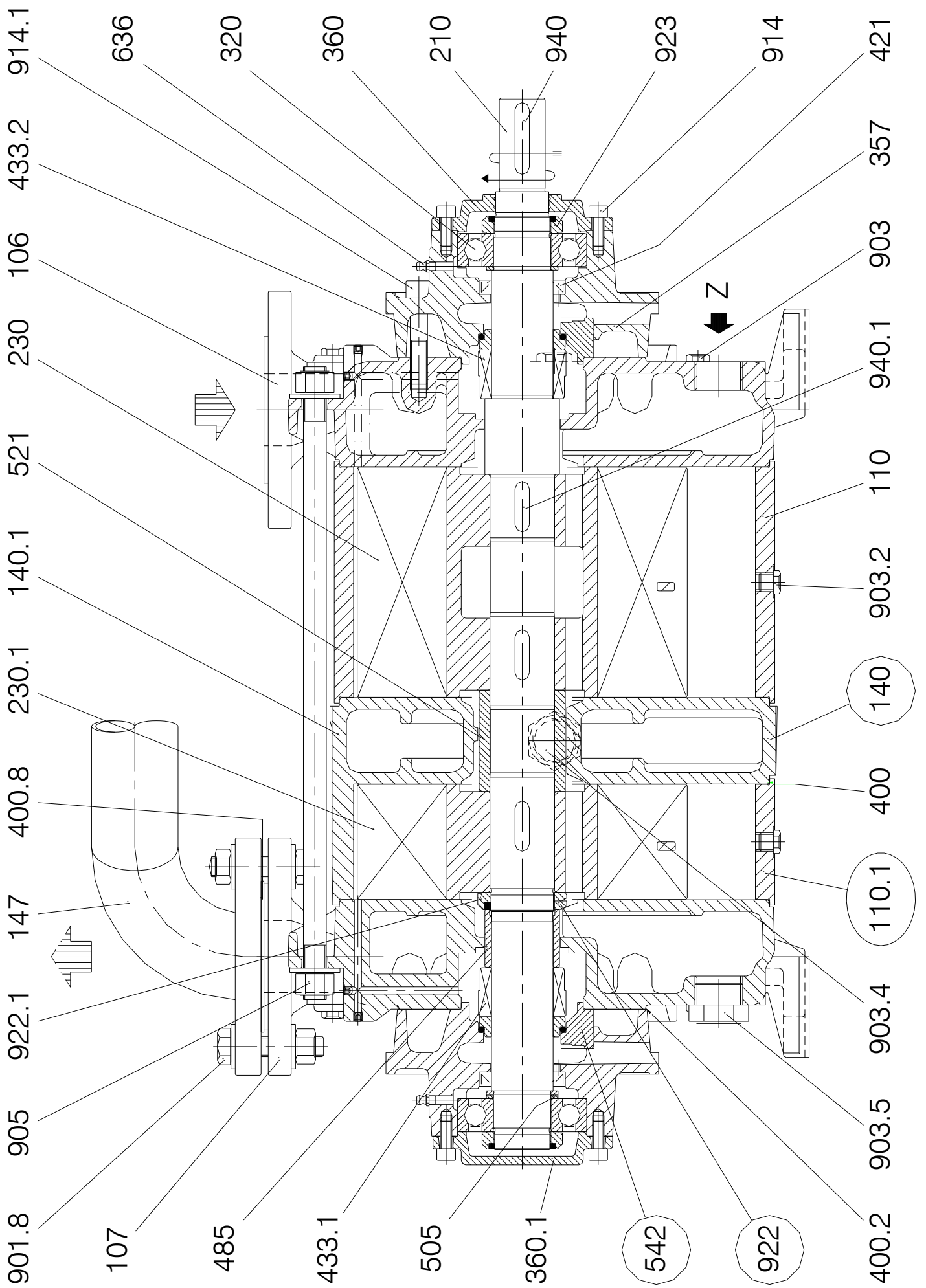

TRHB 50

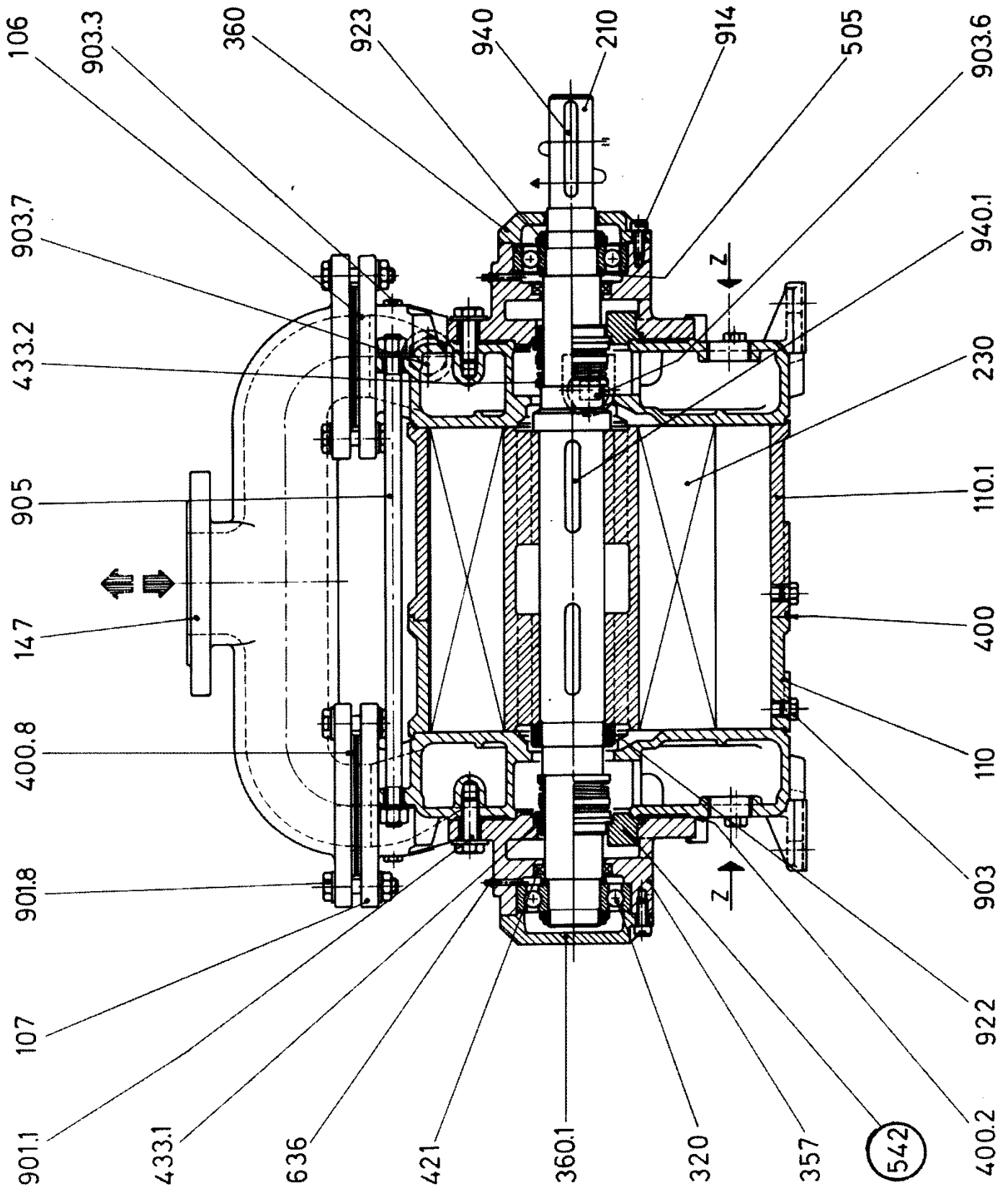

TRSB 100

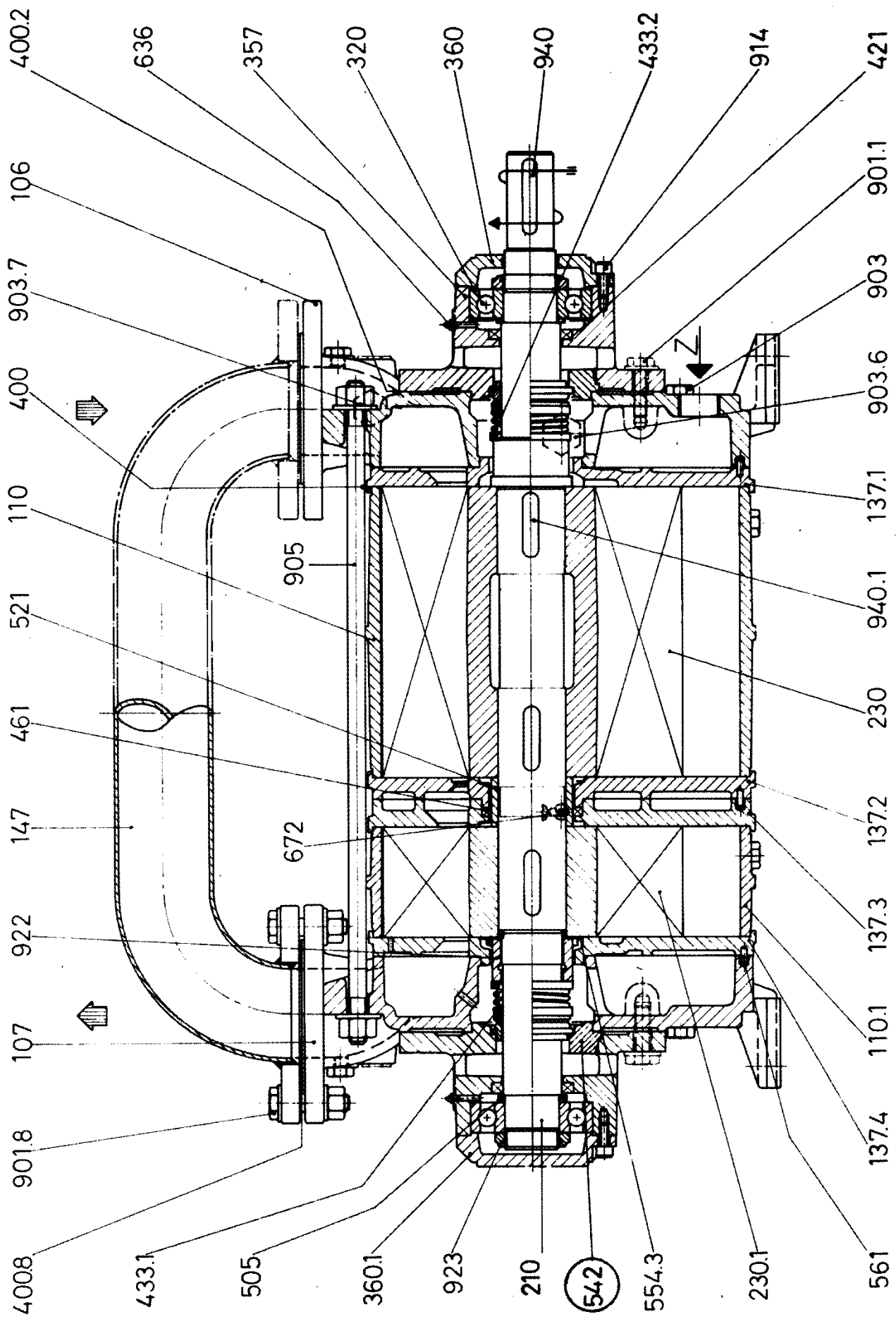

TRHC 80

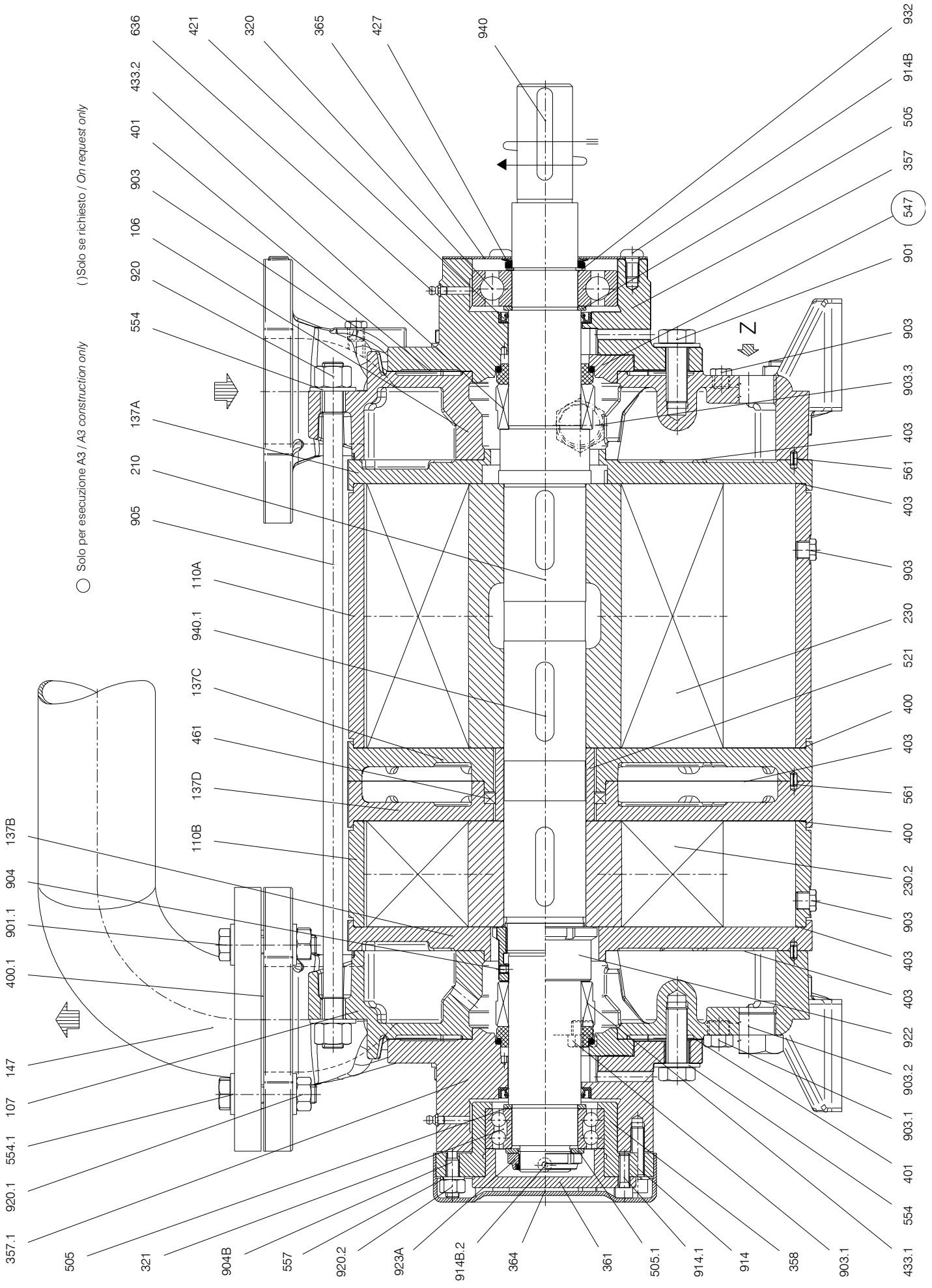

() Solo se richiesto / On request only

○ Solo per esecuzione A3 / A3 construction only

TRHC 80-.../1-C

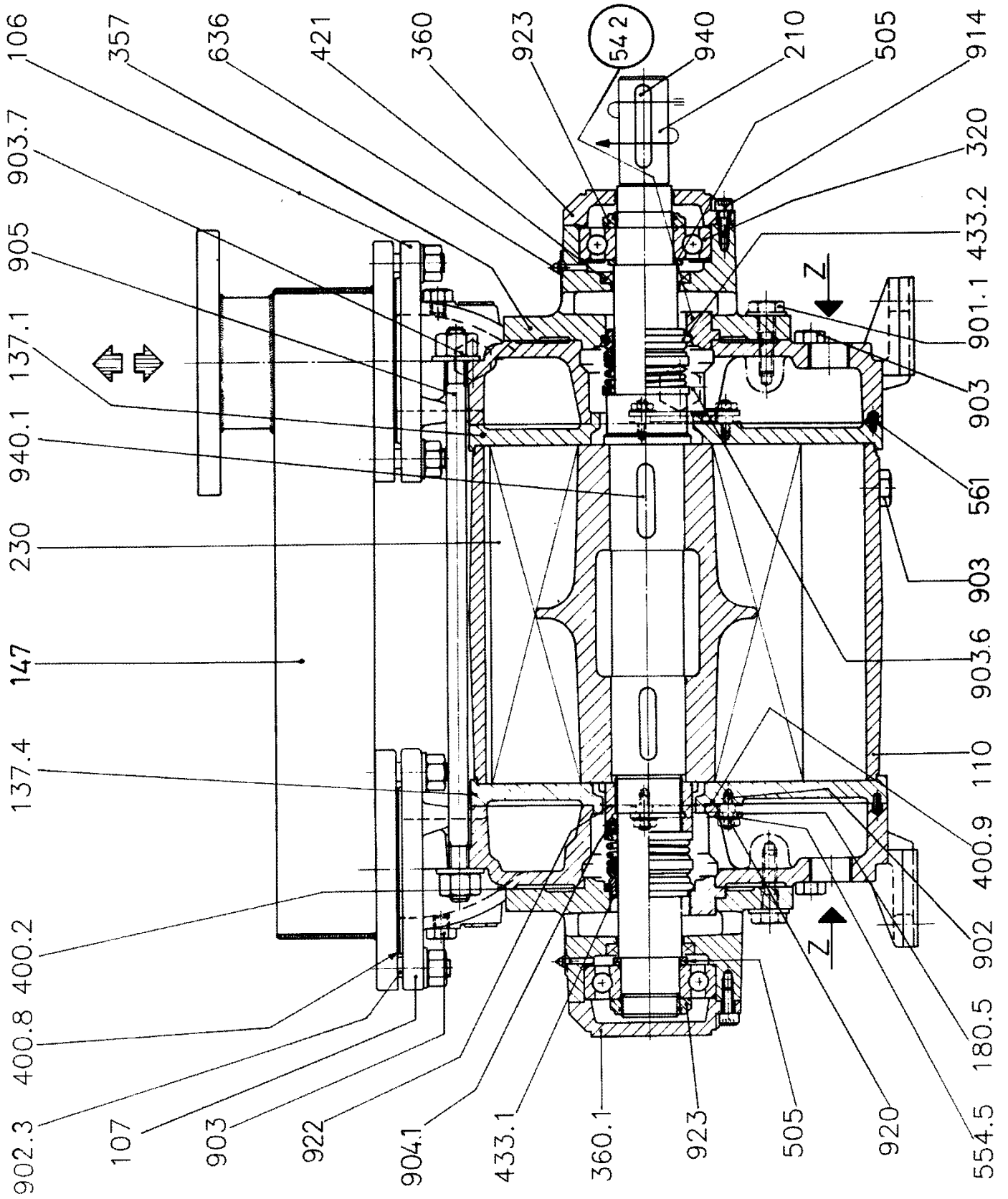

TRSC 100

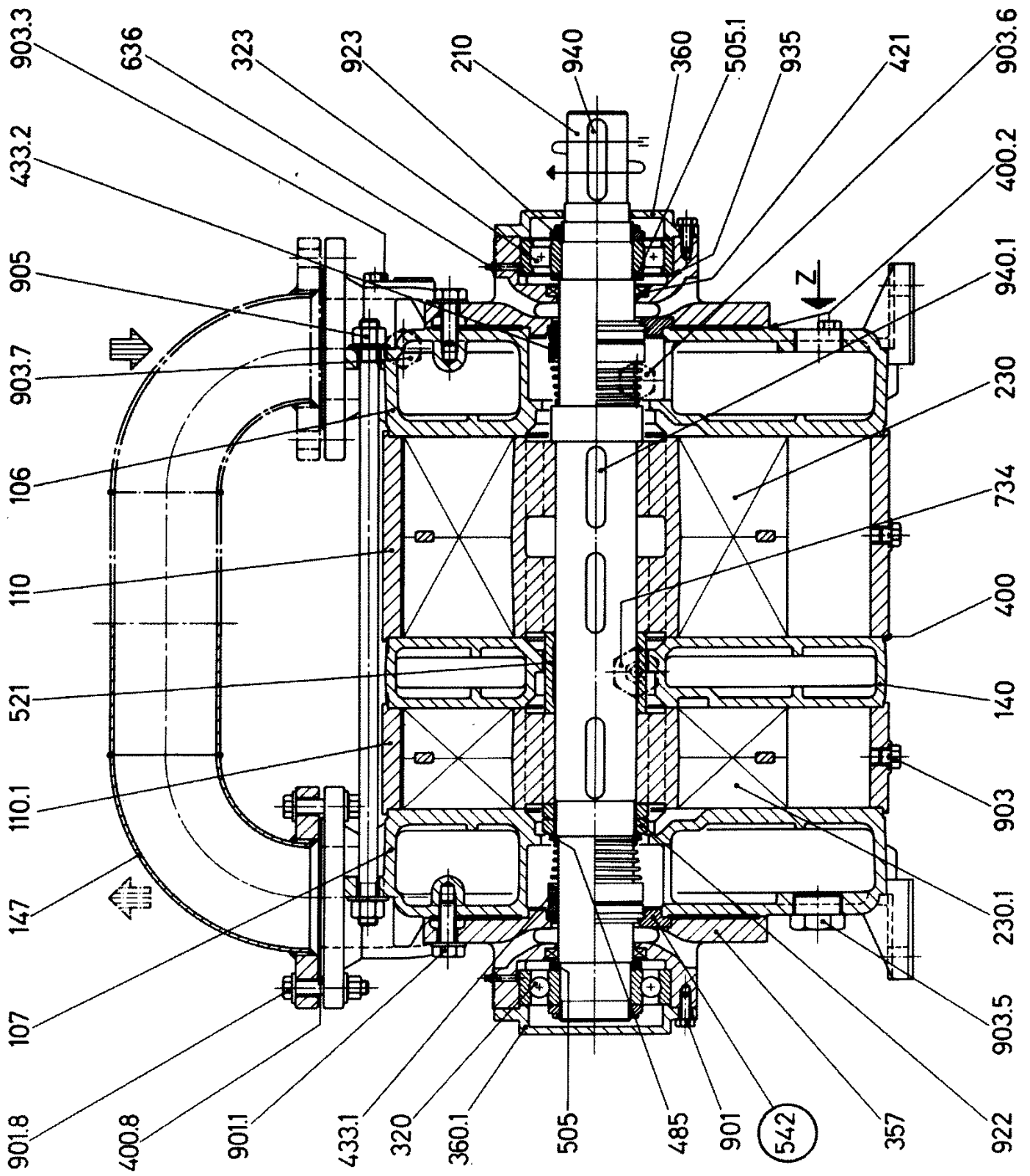

TRHE 100

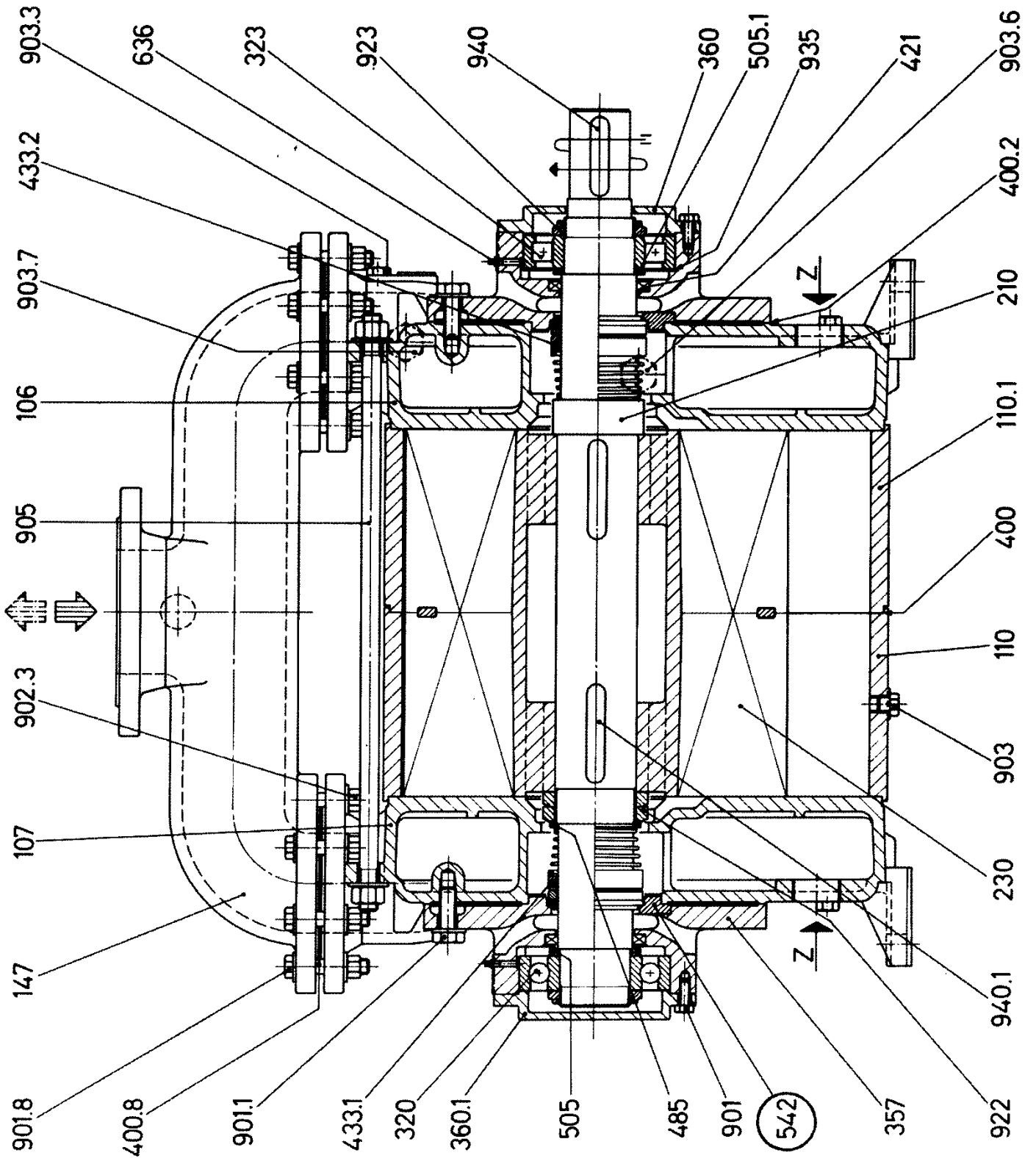

TRSE 125

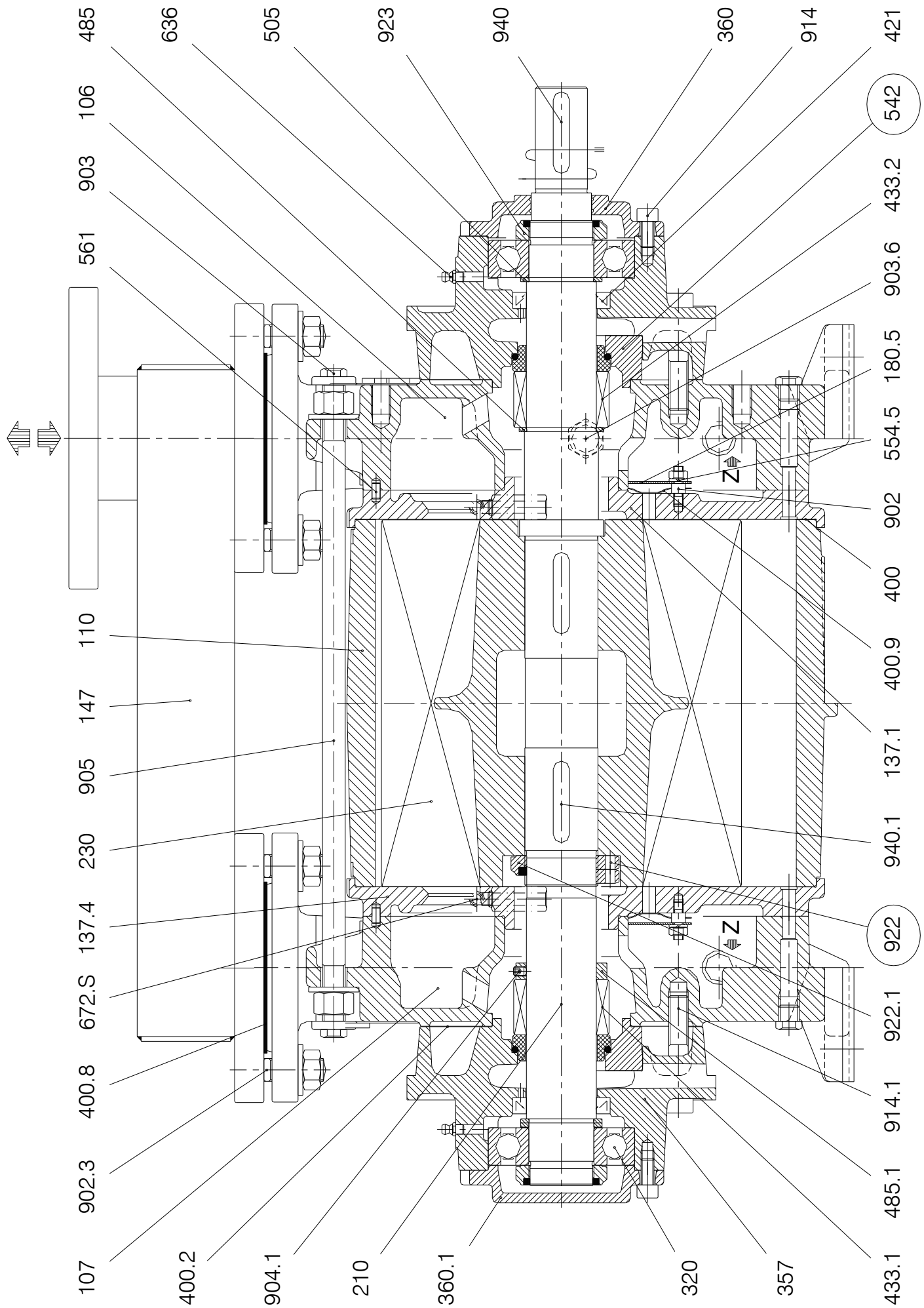

TRVA 65

According to what expected from 2012/19/UE Directive on Waste Electric and Electronic Equipment the electrical pump assembly from us supplied (pump coupled with an electrical motor of Pompetravaini supply or customer supply) placed on the market after the 15th of August 2018 fell within the limits of application of the Directive. As a consequence, conforming to article 14 of the 2012/19/UE Directive of the European Parliament of the 4th of July 2012, Pompetravaini Spa is registered on the Italian list of EEE manufacturer. The electrical pump assembly supplied by Pompetravaini Spa that should be discontinued from use must not be disposed with common waste because it is composed of different materials that can be recycled at the appropriate facilities. If it is not intended to proceed autonomously at the management of the electrical pump assembly at authorized disposal companies it is possible to contact the Pompetravaini branch closer to you that will give you the necessary information on a proper disposal in accordance with mandatory laws.



The pump unit must be previously cleaned up by the pumped product upon disposal.

After reclamation the electrical pump assembly is not potentially dangerous for human health and environment, not containing harmful substances according to 2011/65/UE (RoHs) Directive, but if abandoned in the environment will have a negative impact on the ecosystem.

Sending the electrical pump assembly to an adequate process of disposal and recovery of materials protect the environment and help to limits consumption of available resources with effective recycling of materials.

The abandonment in the environment of the apparatus or the illegal disposal of the same are punished by law.

(blank page)

(blank page)

NOTES

PUMP model	Serial Number	Computer Number	Year of manuf.
---------------------	------------------------	--------------------------	-------------------------

GAS handled	Capacitym ³ /h	Suction Pressurembar	Discharge Press.mbar	Temperature°C
<input type="checkbox"/> Lethal	<input type="checkbox"/> Toxic	<input type="checkbox"/> Noxious	<input type="checkbox"/> Corrosive	<input type="checkbox"/> Malodorous
<input type="checkbox"/>				

Service LIQUID	Capacitym ³ /h	Temperature°C
-------------------------	------------------------------------	------------------------

TOTAL WEIGHTKGS.

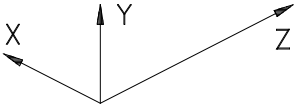
MAXIMUM DIMENSIONS 	X =cm
	Y =cm
	Z =cm

NOISE (measured at 1 m)
Pressure =dB(A)
Power =dB(A)

INSTALLATION	
<input type="checkbox"/> Inside	<input type="checkbox"/> Outside
<input type="checkbox"/> Explosive area	<input type="checkbox"/>

SERVICE	
<input type="checkbox"/> Continuous	<input type="checkbox"/> Intermittent
<input type="checkbox"/>	

MOTOR type / Frame	No Poles	No RevolutionsRPM	Absorbed powerAmp	Installed powerkW /HP
FrequencyHz	SupplyVolt	Enclosure IP.....	Insulation class	Absorbed powerkW /HP

COMMENTS

MONOSTAGE CENTRIFUGAL PUMPS

**MAGNETIC DRIVE
MONOSTAGE CENTRIFUGAL PUMPS**

SELF-PRIMING CENTRIFUGAL PUMPS

**MAGNETIC DRIVE
SELF-PRIMING CENTRIFUGAL PUMPS**

MULTISTAGE CENTRIFUGAL PUMPS

LIQUID RING VACUUM PUMPS

LIQUID RING COMPRESSORS

**PACKAGE VACUUM UNITS WITH PARTIAL OR TOTAL
SERVICE LIQUID RECIRCULATION**

NA5.SM.TRHS.GB00 / PRINTED IN ITALY
Smontaggio TRH-TRS-TRV_C Inglese

Continuing research of POMPETRAVAINI results in product improvements: therefore any specifications may be subject to change without notice.

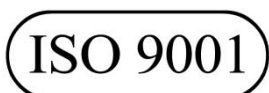

pompetravaini

20022 CASTANO PRIMO (Milano) ITALY
Via per Turbigo, 44
Tel. +39 0331 889000
www.pompetravaini.com