



**IDEAL**  
Auxilliary trolley lift



Main supplier of official dealership networks :



## IDEAL 2.0

100%  
made in  
ITALY



100%  
made in  
Lv8



### | Feature

- Omnidirectional high load wheel with integrated brake
- Self-leveling platform with shaped wood worktop
- Single scissor with double hydraulic cylinder system
- Ergonomic remote controls
- Integrated 5m Power Reel

1.0 t

[CHECK VIDEO HERE](#)

### | Auxiliary trolley Lift for batteries and engines

Special trolley equipped with adjustable lifting platform with 1 T capacity that allows easy access for users under the vehicle for the disassembly of battery packs, engines and transmissions.

### | Dimension

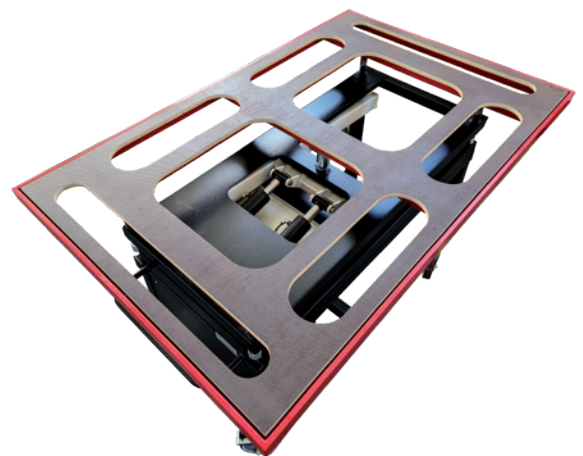
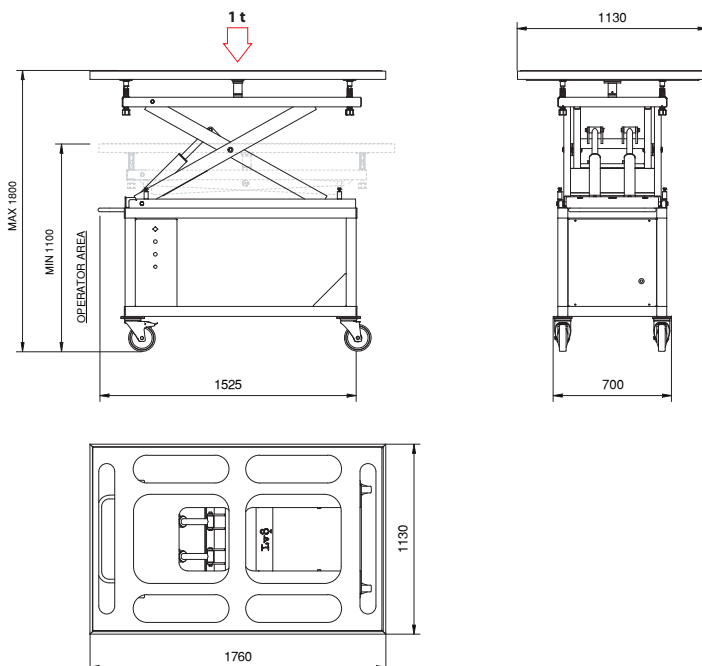

### Wooden shaped worktop

The wooden worktop is specially milled to facilitate the operator to take access to fixing points during disassembly operation of components such as batteries , transmissions. The wood plate has also the exclusive benefit to isolate the high voltage battery.



100%  
made in  
ITALY

100%  
made in  
Lv8



## IDEAL 1.4



### | Feature

- Omnidirectional high load wheels with integrated brake
- Self-leveling platform with shaped wood worktop
- Double scissors with double hydraulic cylinders system
- Ergonomic remote controls
- Crane access optimization
- Integrated 5m Power Reel

1.4 t

[CHECK VIDEO HERE](#)

### | Auxiliary trolley Lift for batteries and engines

Special trolley equipped with adjustable lifting platform with 1.4 t capacity that allows easy access for users under the vehicle for the disassembly of battery packs, engines and transmissions.

### | Dimension

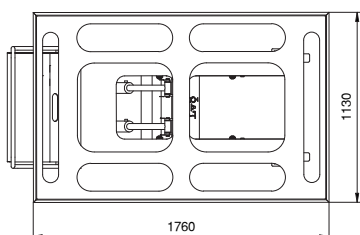
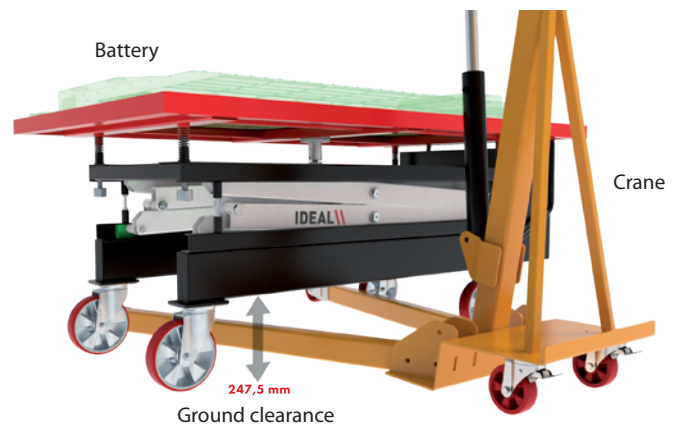
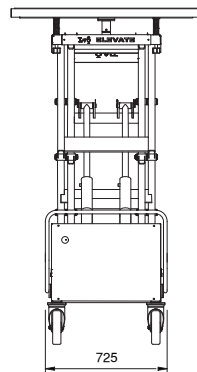
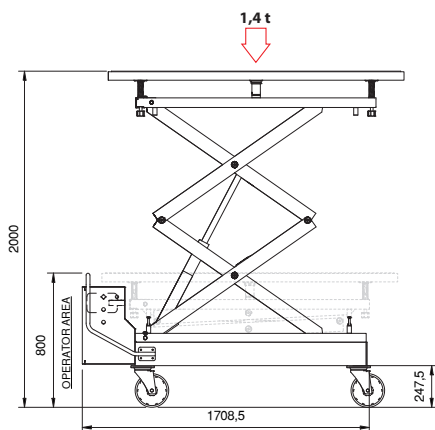

### | Crane access optimized

The **247,5 mm** ground clearance of the frame allows an easy access to most commons cranes for component loading and unloading operations.



## FEATURE

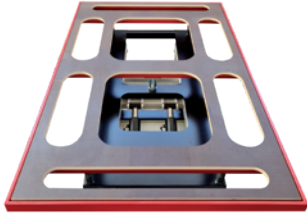

01

Wooden insulated and milled worktop for increased accessibility



02

High efficiency polyethylene sliding pads.



03

Double cylinders hydraulic lifting system.



04

Dead-man control system in low voltage 24V ; Cabled remote controls; 5 m integrated Power reel



05

Omnidirectional high load wheels with integrated brake



06

Anti crush safety stop system to prevent hands injury during closing phase.

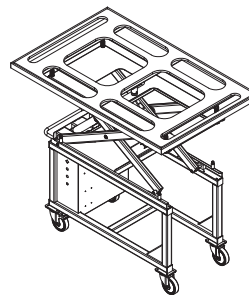

IDEAL 2.0

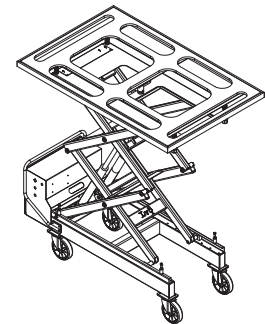

IDEAL 1.4

## TECHNICAL DATA

Max capacity	Kg	1000	1400
Lifting time	sec.	22	22
Lowering time	sec.	20	20
Min.useful height	mm	1100	800
Max. useful height	mm	2000	2000
Top platform dimensions	mm	1760 x 1130	1760 x 1130
Lift length	mm	1525	1700
Lift width	mm	700	725
Power	Volt-Hz-	230 V - 50 Hz	230 V - 50 Hz
Single-phase motor power	kW /HP	1.5	1.5
Control circuit voltage	Volt	24	24
Weight	Kg	200	300
Package dimension		N.1 pallet cm.190x85x130	N.1 pallet cm.180x80x130



Main supplier of official dealership networks :



100%  
made In  
ITALY

100%  
made in  
Lv8



## HOW THEY WORK?

### | Usage scenario

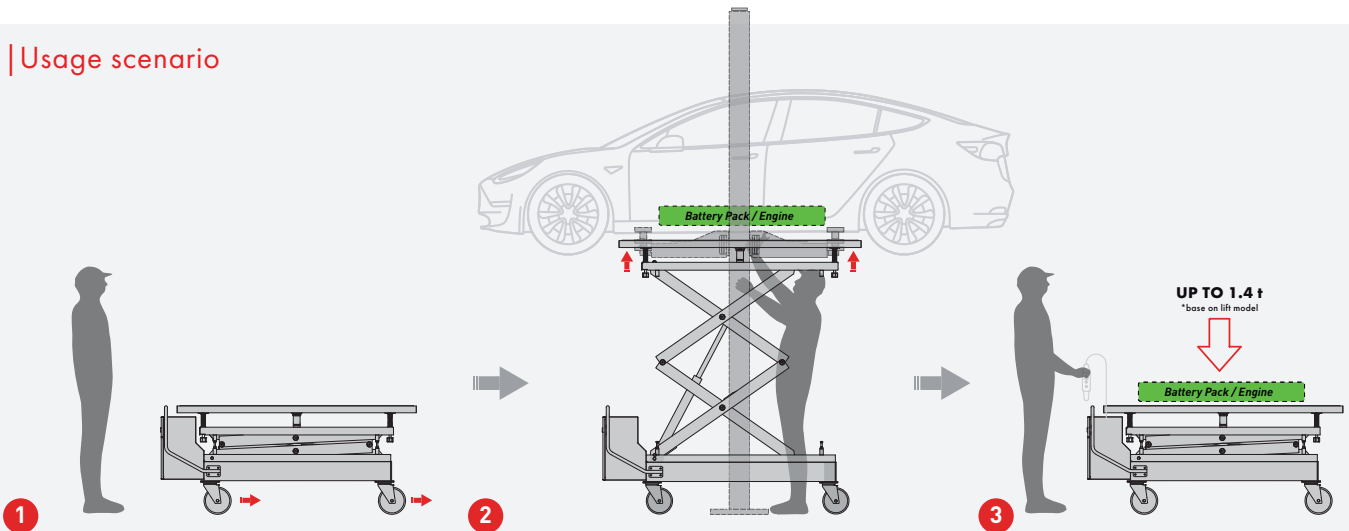

### | Facilitate handling

The 4 omnidirectional wheels with integrated brakes allow a fine and handy handling of ideal trolleys inside the workshop during positioning operations under the car lift.

### | Easy acces

The designed front recessed frame allow operators to easily take access under vehicle body and work directly on components fixing points.

### | Safety Remote controls

Ergonomic dead-man control system in low voltage 24V, equipped with cabled remote controls with magnet that allows you to control the equipment remotely and safely and reach a millimetric approach .

### | Adjustment systems

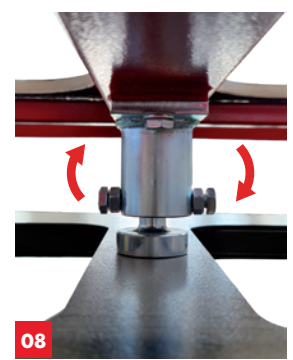
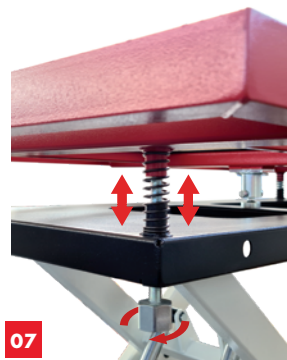
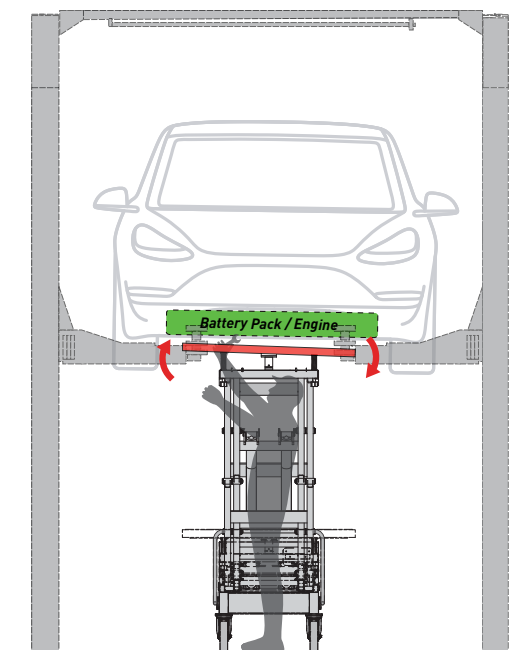

### Perfect alignment

The alignment system is composed by a central stabilization bar that can be unlocked trough dedicated adjustment screws ,allowing a perfect centering and adhesion of the wood worktop to the battery in every work condition.



**ELEVATE**

Via Peppone e Don Camillo, 11 - Z.I. Dugara  
CAP 42041 - Brescello (Reggio Emilia) - ITALY

Ph. +39 0522 687907

**Fax +39 0522 684498**

[www.lv8elevate.it](http://www.lv8elevate.it) - [info@lv8.it](mailto:info@lv8.it)

**[www.lv8elevate.it](http://www.lv8elevate.it)**

Tutti i diritti riservati. Ogni riproduzione, anche parziale, del presente catalogo è vietata senza previa autorizzazione scritta. Il produttore si riserva il diritto di modificare od implementare la gamma dei prodotti a catalogo in qualsiasi momento e senza preavviso.

All rights reserved. Any reproduction, even partial, of the present catalog is not allowed without any previous written authorization. The manufacturer reserves the right to modify or implement the range of products in the catalog at any time and without notice.