

MA STAR 6.5 STOCK

LIFTING TECHNOLOGY



MA STAR triple safety

VP 451189

Two Post Lift with 6500 kg load capacity

DESCRIPTION

- 6500 kg load capacity
- Triple safety
- Symmetrical support arms
- Variable installation width
- Accommodates vehicles from small cars to vans with long wheelbase
- High-quality powder coating:
 - window grey, RAL 7040 (columns)
 - anthracite grey, RAL 7016 (lifting carriage, support arms)

SCOPE OF DELIVERY

- 2 columns with control panel on operating column
- 4 symmetrical support arms, double telescopic
- Support discs with plug-in system
- Cable bridge
- Spindle oil (0.5 l)
- Operating instructions
- CE/UKCA Declaration of Conformity
- Transport packaging

ACCESSORIES

COLUMN ACCESSORIES

- | | |
|-----------|--|
| VZ 990488 | Energy set: 1x compressed air, 2x 230 V |
| VZ 990500 | Energy set on operating column: 1x safety compressed air, 2x 230 V |
| VZ 971612 | Additional control panel on opposite column |
| VZ 990489 | Energy set on opposite column: 1x compressed air, 2x 230 V |
| VZ 990501 | Energy set on opposite column: 1x safety compressed air, 2x 230 V |
| VZ 990504 | Energy set on operating column: 1x safety compressed air, 1x 230 V; only with VZ 990505 Beeper |
| VZ 990505 | Beeper "CE Stop", volume adjustable |
| VZ 990503 | Power socket combination: 2x 230 V, 1x 400 V, 1x FI switch |
| VZ 971591 | Holder for impact wrench and 6 sockets |
| VZ 971592 | Document holder (1 pce) |
| VZ 971593 | Tray for 2 support extenders, mountable to columns (1 pce) |
| VZ 971224 | Tray for 2.2 support extenders, mountable to wall (2 pcs) |
| VZ 990493 | LED illumination (1 pce), plug-in |

SUPPORT ARM ACCESSORIES

- | | |
|-----------|---|
| VZ 971220 | Support disc extender 50 mm galv. (2 pcs) |
| VZ 971221 | Support disc extender 100 mm galv. (2 pcs) |
| VZ 971222 | Support disc extender 150 mm galv. (2 pcs) |
| VZ 971223 | Support disc extender 200 mm galv. (2 pcs) |
| VZ 971573 | Support disc extender 130 mm galv. (2 pcs) |
| VZ 975050 | Non-skid device for vehicles with longitudinal frame up to 100 mm width (2 pcs) |
| VZ 971111 | Lashing straps as tilt protection for gearbox removal (2 pcs) |

ACCESSORIES

VZ 971226	Prism support for MB Sprinter/VW Crafter (2 pcs)
VZ 975601	Support arbor (2 pcs) for MB Sprinter/VW Crafter
VZ 971539	Stainless steel tray for small parts, magnetic (2 pcs)
VZ 971461	Wheel engaging support, load capacity 1000 kg each (4 pcs)

SAFETY DEVICE ACCESSORIES

VZ 971104	Light barrier to prevent contact with ceiling
-----------	---

OTHER ACCESSORIES

VZ 971639	Drilling template MA STAR 6.5
VZ 971611	CEE coupler 32A for on-site cable connection
VZ 990490	Connection socket for in-ground wiring

ADDITIONAL SERVICES

VT 995023	Transport Two post lift up to 6500 kg load capacity
VM 995040	Installation costs Two post lift, electromechanical, up to 6500 kg load capacity
VM 996232	Installation costs Energy set
VM 996233	Installation costs Additional control panel on opposite column
VM 996072	Installation costs Ceiling light barrier
VM 999085	Installation material Injection system MA STAR 6.5
VM 999081	Injection mortar cartridge 500 ml (1 pce)

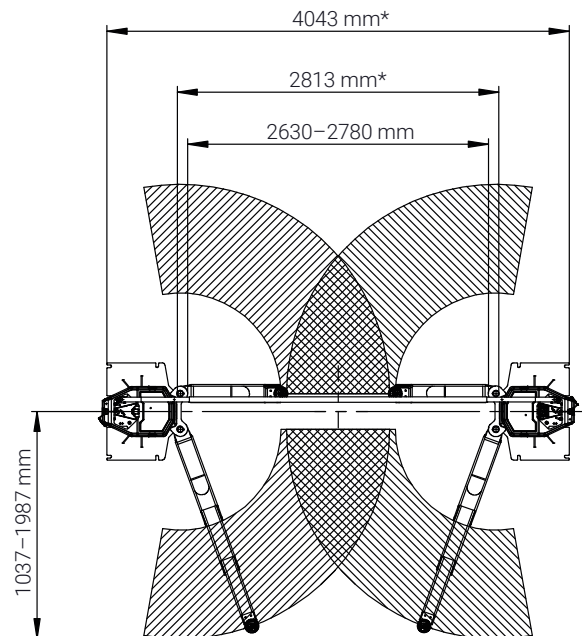
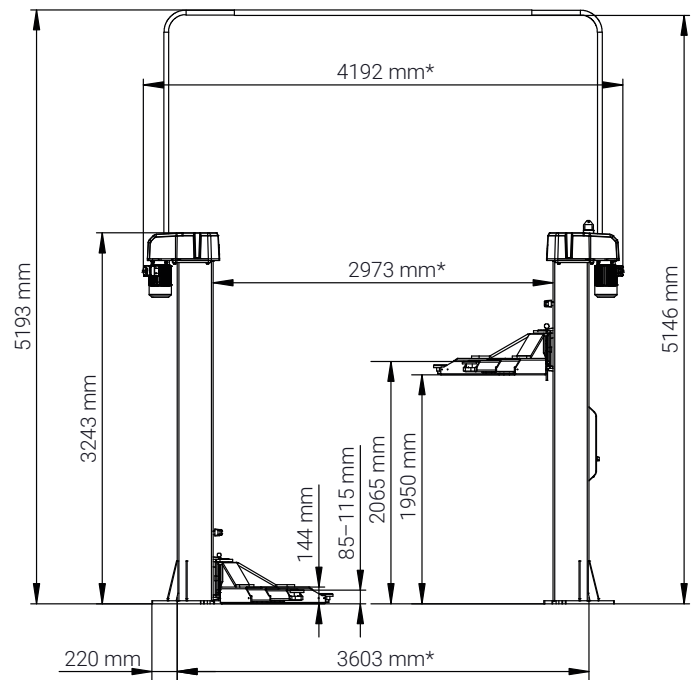

*Dimensions refer to drive-through width of 2630 mm

TECHNICAL DATA

Load capacity CE	6500 kg
Lifting height max.	2065 mm
Lifting/lowering time (load-dependent) approx.	44/44 s
Bottom clearance of complete support arm	144 mm
Adjustment range of support disc	85 - 115 mm
Pick-up range of support arms	1037 - 1987 mm
Overall width*	4192 mm
Outside base plates*	4043 mm
Outside columns*	3603 mm
Inside columns*	2973 mm
Drive-through width	2630 - 2780 mm
Column height	3243 mm
Overall height max. (with cable bridge)	5193 mm
Drive power	2 x 4.0 kW
Power supply	3/N/PE 400 V 50 Hz
Fuse	C32 A
Weight	1520 kg
Packaging dimensions (L x W x H)	
2 Packages, each with	3185 x 800 x 1100 mm
Required concrete quality	C 20/25
Required concrete slab thickness without screed min.	220 mm