

VAS 741 043



Spare Parts
Pieces de Rechange
Ersatzteilliste
Запасные части

Tavole ricambi
Tabla de Repuestos
Figuras das Pecac



INDEX		Page
EAZ0090G13A_B	RACING CABINET	4
EAZ0090G17A_E	TILTING TOWER	7
EAZ0089G77A_C	24" TURNTABLE C/CENTER	12
EAZ0089G78A_C	24" TURNTABLE GT	15
EAZ0090G09A_B2	MOTOR ASSY INVERTER	18
EAZ0033G64A_B3	MOTOR ASSY 2 SPEED	21
EAZ0103G17A_C	PEDAL ASSY 2 SPEED ENHANCED POTENTIO	23
EAZ0122G37A_A	NA INVERTER ENHANCED POTENTIOMETER	26
EAZ0122G36A_A	CE INVERTER ENHANCED POTENTIOMETER	28
EAZ0116G59A_B	JAPAN INVERTER ENHANCED POTENTIOM.	30
EAZ0090G15A_A1	BEAD BREAKER DEVICE	32
EAZ0090G16A_A	BEAD BREAKER PEDAL	35
EAZ0033G72A_B	TUBELESS BEADING DEVICE	37
EAZ0090G12A.A2	TOOLBOX BAR/PSI	39
EAZ0103G78A_A2	FILTER AND LUBRICATOR ASSY	42
EEWH556AWD_A	ELECTRIC DIAGRAM	44
TEEWH001T_A1	TOP SIDE BEAD SEATING DIAGRAM	45
TEEWH001T_A2	TOP SIDE BEAD SEATING DIAGRAM	46
TEEWH003T_A1	TURNTABLE BEAD SEATING DIAGRAM	47
TEEWH003T_A2	TURNTABLE BEAD SEATING DIAGRAM	48

UPDATING GUIDE:

Sep.18: EAZ0090G09A_B1 > B2
EAZ0033G64A_B2 > B3

- (**GB**): in a given list, components sharing the same letter (A,B,C...), in the “Note” column are compatible.
- (**FR**): dans une table, les composants qui présentent la même lettre (A,B,C...) dans la colonne “Note”, sont compatibles.
- (**DE**): Die in einer Tabelle aufgeführten Komponenten, die in der Spalte “Anmerkung” mit demselben Buchstaben (A,B, C...) gekennzeichnet sind, sind kompatibel.
- (**RU**): В данном списке компоненты с одинаковыми буквами (А, В, С) в графе “Примечания” совместимы.
- (**IT**): all’interno di una tabella, i componenti che presentano la medesima lettera (A,B,C...) nella colonna “Nota”, sono compatibili.
- (**ES**): dentro de una tabla, los componentes de la columna “Nota” que poseen la misma letra (A, B, C...) son compatibles.
- (**PT**): em uma determinada tabela, os componentes que apresentarem a mesma letra (A,B,C...) na coluna “Nota”, são compatíveis.]

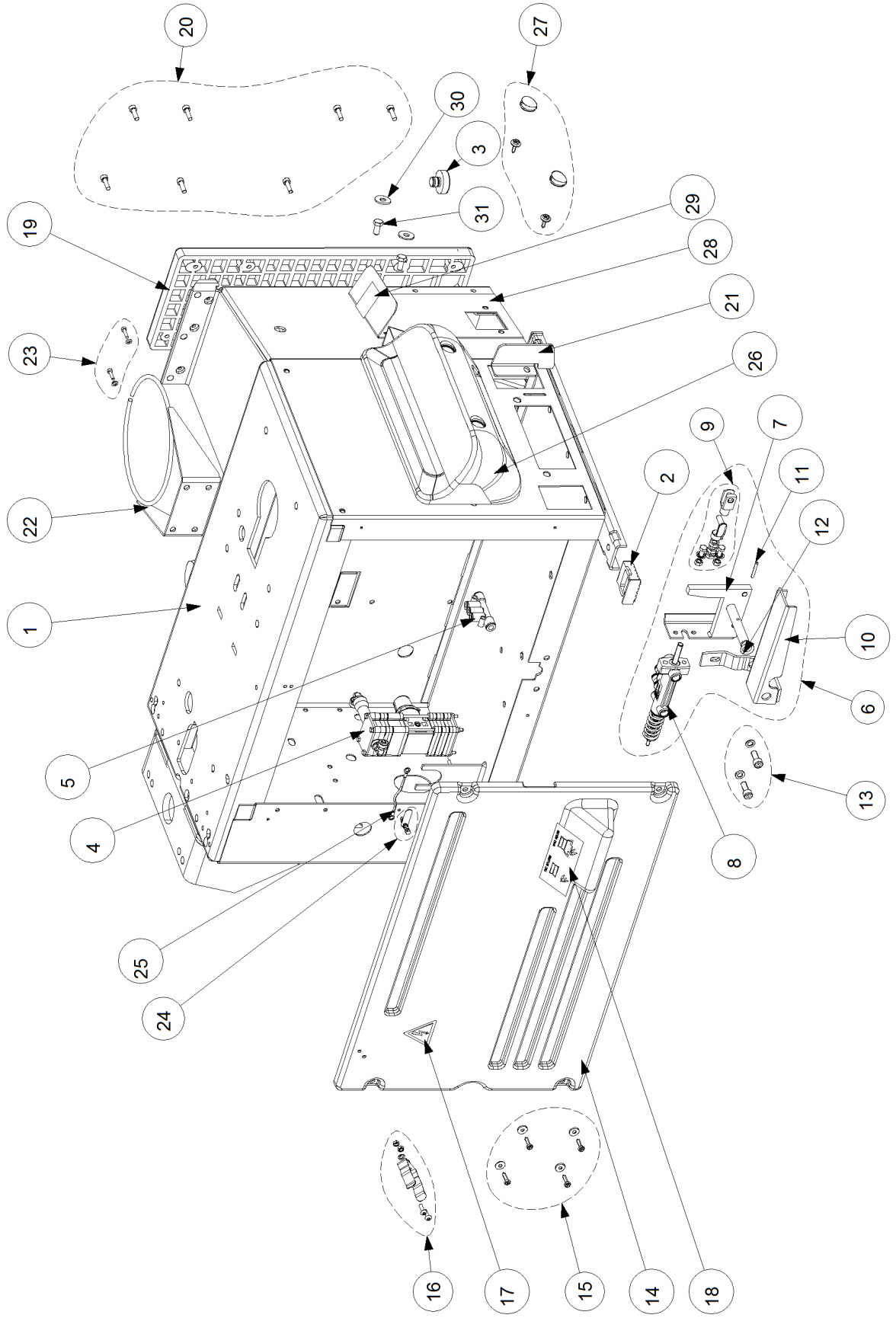

Pos	Code	Designation Designazione ОПИСАНИЕ	Désignation Designación	Bezeichnung Designação	N.	Note Nota HOTa	A	B	C
1	EAS2120G21A	RACING CABINET CASSONE RIBASSATO КАБИНЕТ RACING	CAISSON ABAISSE CAJÓN REBAJADO	GEFAHRENSCHILD VDE CAIXA REBAIXADA	1	RAL 7015	X		
2	EAC0097G52A	FOOT-SQUARE PIEDE QUADRATO ОПОРА КВАДРАТНАЯ	SUPPORT CARRE SOPORTE PIE CUADRADO	FUSS, RECHTECKIG PÉ QUADRADO	4		X		
3	EAC0078G03A	CIRCULAR RUBBER FOOT PIEDE CIRCOLARE РЕЗИНОВАЯ ОПОРА КРУГЛАЯ	SABOT CIRCULAIRE PIE CIRCULAR	RUNDER FUSS PE CIRCULAR	1			X	
4	EAA0384G22A	VALVE, AIR CONTROL VALVOLA LIMITATRICE PRESSIONE КЛАПАН	CLAPET REDUCTEUR DE PRESSION VALVOLA LIMITATRICE PRESSIONE	VENTIL LUFTREGELUNG VÁLVULA LIMITADORA PRESSÃO	1	(4 bar)	X		X
5	1-12379A	DISTRIBUTOR, MULTI-TEE 08-06 DISTRIBUTORE MULTI-TEE 08-06 РАСПРЕДЕЛИТЕЛЬ MULTI-TEE 08-06	DISTRIBUTEUR MULTI TE 08-06 DISTRIBUIDOR MULTI T 08-06	VERTEILER MULTI-TEE 08-06 DISTRIBUIDOR MULTI-TEE 08-06	1	(option)	X		
6	EAA0384G14A	GROUP, BEAD INFLATING PEDAL GRUPPO PEDALE GONFIATORE ПЕДАЛЬ	GROUPE PEDALE POMPE GRUPO, PEDAL INFLADOR	PEDALGRUPPE AUFPUMPVORRICHTUNG PEDAL INSUFLADOR	1		X		
7	EAS2134G52A	GT PEDAL SUPPORT SUPPORTO PEDALE GT ДЕРЖАТЕЛЬ ПЕДАЛИ GT	SUPPORT PEDALE SOPORTE PEDAL	PEDALHALTER SOPORTE PEDAL GT	1		X		
8	EAA0329G75A	VALVE, BEAD INFLATING VALVOLA COMANDO GONFIATUBELES КЛАПАН НАКАЧКИ	SOUPAPE CONTROLE GONFLE PNEU S/CHAM VALVULA MANDO INFLACION NEUM.S/CAMA	VENTILBLOCK- STEUERUNG FÜLLEINHEIT VÁLVULA PARA PEDALEIRA	1		X		X
9	EAK0306G32A	SCREWS AND BOLTS FOR GT VALVE KIT VITI VALVOLA GT ВИНТЫ КРЕПЛЕНИЯ КЛАПАНА ВЗРЫВНОЙ Н/	KIT VIS SOUPAPE GT KIT TORNILLOS VÁLVULA GT	SCHRAUBENSATZ GT-VENTIL KIT PARAFUSOS VÁLVULA GT	1		X		
10	EAS2068G87A	INFLATOR PEDAL CATAPHOR. BLK PEDALE GONFIATUB. CATAFOR. NERA ПЕДАЛЬ НАКАЧКИ	PEDALE POMPE LAQUAGE HEPOXY NOIR PEDAL HINCHADOR TUBEL.NEGRO	PEDAL SCHLAUCHL.R.PUMPE KATAPHOR SCH PEDAL INFLATUB. CATAFOR. PRETA	1		X		
11	1-6652	PIN - STRAIGHT SLOTTED 4X30 SPINA ELASTICA ПАЛЕЦ С ПАЗОМ 4X30	BROCHE ELASTIQUE PASADOR ELÁSTICA	STIFT, ELASTISCH 4X30 DIN 1481 TOMADA ELASTICA	1	4X30 DIN 1481	X		
12	8-19514A	O-RING 4055 O-RING 4055 КОЛЬЦО	JOINT OR JUNTA OR	DICHTUNG ANEL -O	1	4055		X	
13	EAK0306G33A	SCREWS AND BOLTS FOR GT PEDAL KIT VITI PEDALE GT ВИНТЫ КРЕПЛЕНИЯ ПЕДАЛИ ВЗРЫВНОЙ НАИ	KIT VIS PEDALE GT KIT TORNILLOS PEDAL GT	SCHRAUBENSATZ GT-PEDAL KIT PARAFUSOS PEDAL GT	1		X		
14	EAC0087G69A	SIDE PANEL , LOW CABINET FIANCATA CASSONE RIBASSATO termoform. БОКОВАЯ ПАНЕЛЬ	COTE CHASSIS BAS LATERAL CAJON	SEITE KASTEN, GESUNKEN LATERAL CAIXOTE REBAIXADO termoform.	1			X	
15	EAK0306G28A	CABINET SIDE SCREWS KIT KIT VITI FIANCATA CABINET КОМПЛЕКТ ВИНТОВ КРЕПЛЕНИЯ БОКОВОЙ Г	KIT VIS PARTIE LATERALE CABINET KIT TORNILLOS LATERAL CABINET	SCHRAUBENSATZ SEITENPLATTE SCHRANK KIT PARAFUSOS LATERAL CABINET	1		X		
16	EAK0306G31A	GT SUPPORT FOR SIDE PANEL KIT ATTACCO GT FIANCATA ДЕРЖАТЕЛЬ СОПЛА ВЗРЫВНОЙ НАКАЧКИ	KIT RACCORD GT PANNEAU LATERAL KIT CONEXIÓN GT LATERAL	ANSCHLUSSSET GT-SEITENPLATTE KIT JUNÇÃO GT LATERAL	1			X	
17	8-23562A	STICKER, DANGER VDE TARGHETTA PERICOLO VDE НАКЛЕЙКА "ОПАСНО"	PLAQUETTE DANGER VDE TARJETA PELIGRO	GEFAHRENSCHILD VDE PLACA PERIGO VDE	1			X	

A = available - disponible - vorhanden - beschikbaar
= disponibile - disponible - disponivel - Доступно

B = on request - sur demande - auf Antrag - op aanvraag
= a richiesta - a petición - no pedido - По запросу

C = suggested - suggeré - vorgeschlagene - aanbevolen
= consigliato - sugerido - sugerido - Предлагается

Pos	Code	Designation Designazione ОПИСАНИЕ	Désignation Designación	Bezeichnung Designação	N.	Note Nota HOTa	A	B	C
18	EAL0413G34A	STICKER- INFLATOR TARGA GONFIATUBELESS НАКЛЕЙКА НАКАЧКА	ETIQUETTE GONFLEUR ETIQUETA INFLADOR	SCHILD TUBELESS-FÜLLVORRICHTUNG PLACA INFLATUBELESS	1			X	
19	EAC0099G22A	PAD- SUPPORT, BEADBREAKER TAMPONE ARROGGIO STALLONATORE ОПОРА РАЗБОРТИРОВЩИКА	PALIER APPUI DETALONNEUR TAMPÓN SOPORTE DESTALONADOR	AUFLAGEKISSEN ABDRÜCKER TAMPAO APOIO DESMON. PNEU	1		X		X
20	EAK0306G29A	SCREWS AND BOLTS FOR BEAD BR. PAD KIT VITI ARROGGIO STALLONATORE БОЛТЫ КРЕПЛЕНИЯ ОПОРЫ РАЗБОРТИРОВЛ	KIT VIS APPUI DETALONNEUR KIT TORNILLOS APOYO DESTALONADOR	SCHRAUBENSATZ FÜR ABDRÜCKER-AUFLAGI KIT PARAFUSOS APOIO DESMONT. PNEU	1		X		
21	EAS2100G95A	PEDAL-REVERSER PROTECTION PROTEZIONE PEDALE INVERTITORE ОГРАНИЧИТЕЛЬ	PROTECTION PÉDALE INVERSEUR PROTECCIÓN PEDAL INVERSOR	SCHUTZ UMKEHRPEDAL KTL PROTEÇÃO PEDAL INVERSOR	1		X		
22	EAA0349G76A	RING- BOX, GREASE ANELLO PORTAGRASSO ZINCATO BIANCO КОЛЬЦО ЕМКОСТИ СО СМАЗКОЙ	COURONNE BOITE GRAISSE ANILLO PORTAGRASA GALVANIZADO BLANCC	RING F. MONTAGEPASTEBEHÄLTER ANEL PORTA-LUBRIFICANTE ZINC. BRANCO	1			X	
23	EAK0306G30A	SCREWS AND BOLTS FOR RING KIT VITI ANELLO PORTAGRASSO ВИНТЫ И ГАЙКИ КРЕПЛЕНИЯ КОЛЬЦА ДЕРЖ	KIT VIS ANNEAU GRAISSEUR KIT TORNILLOS ANILLO PORTAGRASA	SCHRAUBENSATZ F. RING FÜR MONTAGEPAS KIT PARAFUSOS ANEL PORTA-LUBRIFICANTE	1			X	
24	EAK0279G95A	GROUND PLATE KIT KIT TARGHETTA TERRA ТОЧКА ЗАЗЕМЛЕНИЯ, КОМПЛЕКТ	KIT PLAQUETTE TERRE KIT PLACA TIERRA	SET ERDUNGSSCHILD KIT PLACA TERRA	1		X		
25	EAW0282G22A	CABINET GROUNDING CABLE CAVO DI TERRA CASSONE КАБЕЛЬ ЗАЗЕМЛЕНИЯ КОРПУСА	CABLE DE TERRE BATI CABLE DE TIERRA CAJA	ERDUNGSKABEL SCHRANK CABO DE TERRA CAIXA	1		X		
26	EAC0114G09A	FRONT PLASTIC PEDALS PROTECTION PROTEZIONE ANTERIORE PEDALIERA КОЖУХ ЗАЩИТЫ ПЕДАЛЕЙ ПЕРЕДНИЙ ПЛАС	PROTECTION ANTERIEURE PEDALLIER PROTECCIÓN ANTERIOR PEDAL	VORDERER SCHUTZ PEDAL PROTEÇÃO ANTERIOR PEDALEIRA	1		X		
27	EAK0317G23A	KIT, FIXING FOR PEDAL PROTECTION KIT FISSAGGIO CARTER PEDALIERA КРЕПЛЕНИЕ КОЖУХА ПЕДАЛЕЙ ЗАЩИТНОГО	KIT FIXATION CARTER PEDALIER KIT FIJACIÓN PROTECCIÓN PEDAL	BEFESTIGUNGSSATZ GEHÄUSE PEDAL KIT FIXAÇÃO CÂRTER PEDALEIRA	1			X	
28	EAS2116G78A	BEAD-BREAKER BLACK COVER PLATE LAMIERA CHIUSURA STALLONATORE NERO E КОЖУХ ЧЕРНЫЙ	TOLE FERMETURE DETALONNEUR NOIR CHAPA DE CIERRE DESTALONADOR NEGRO F	VERSCHLUSSBLECH ABDRÜCKER SCHWARZ CHAPA FECHAMENTO DESM. PNEU PRETO RI	1		X		
29	EAL0413G33A	STICKER,PEDAL BEAD-BREAKER TARGA PEDALE STALLONATORE НАКЛЕЙКА ПЕДАЛИ РАЗБОРТИРОВЩИКА	ETIQUETTE PEDALE DETALONNEUR TARJETA PEDAL DESTALONADOR	SCHILD ABDRÜCKPEDAL PLACA PEDAL DESMONT. PNEU	1		X		
30	1-17841	WASHER - d. 8X24 RONDELLA COMUNE d.8x24 ZINC. ШАЙБА 8X24	RONDELLE d.8X24 ARANDELA COMUN D.8X24 GALVANIZ.	SCHEIBE B 8,4 -A2J ARRUELA COMUN d.8x24 ZINC.	1	d. 8X24 UNI6593	X		
31	1-32501A	SCREW 8X16 8G VITE TE ВИНТ 8X16	VIS H TORNILLO TE	SECHSKANTSCHRAUBE M8 x 16 8.8 A2J PARAFUSO TE	1		X		

A = available - disponible - vorhanden - beschikbaar
= disponibile - disponible - disponivel - Доступно

B = on request - sur demande - auf Antrag - op aanvraag
= a richiesta - a petición - no pedido - По запросу

C = suggested - suggeré - vorgeschlagene - aanbevelen
= consigliato - sugerido - sugerido - Предлагается

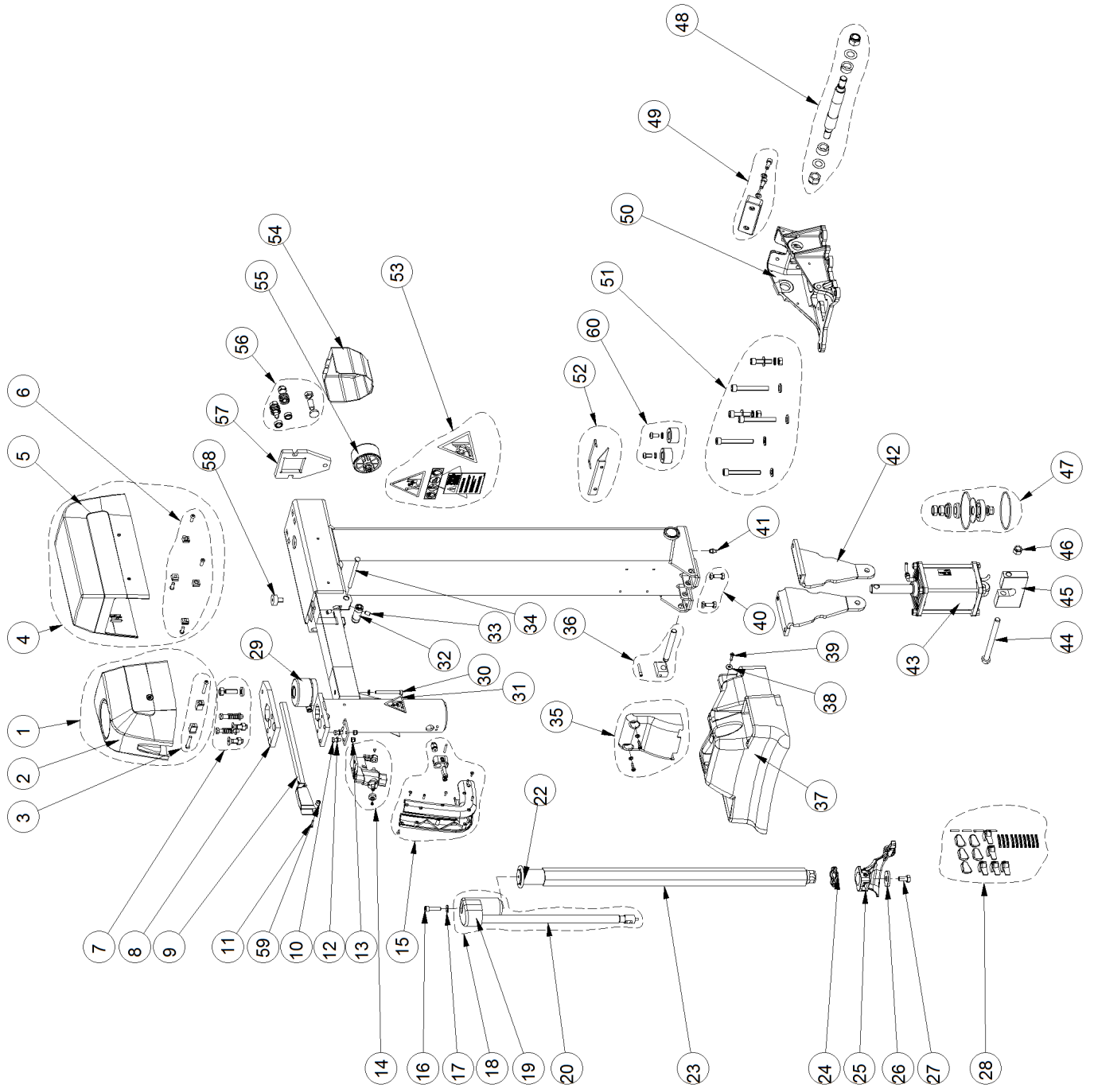

Pos	Code	Designation Designazione ОПИСАНИЕ	Désignation Designación	Bezeichnung Designação	N.	Note Nota HOTa	A	B	C
1	EAK0317G26A	KIT, CARTER + SPACERS KIT CARTER + DISTANZIALI КОЖУХ В КОМПЛЕКТЕ С ПРОСТАВКАМИ	KIT CARTER + ENTRETOISES KIT CARTER + DISTANCIADORES	SATZ GEHÄUSE + DISTANZSTÜCKE KIT CÂRTER + DISTANCIAS	1	SLIDING ARM		X	
2	EAC0114G11A	TOP COVER FOR SLIDING ARM CARTER SUPERIORE BRACCIO SCORR. КОЖУХ ВЕРХНИЙ РЫЧАГА В КОМПЛЕКТЕ	CARTER SUPERIEUR BRAS COUL. CARTER SUPERIOR BRAZO DESL.	OBERES GEHÄUSE VERSCHIEBB. ARM CÂRTER SUPERIOR BRAÇO DESL	1		X		
3	EAK0317G24A	KIT, FIXING FOR CARTER KIT FISSAGGIO CARTER КОМПЛЕКТ КРЕПЛЕНИЯ КОЖУХА	KIT FIXATION CARTER KIT FIJACIÓN CARTER	BEFESTIGUNGSSATZ GEHÄUSE KIT FIXAÇÃO CÂRTER	1			X	
4	EAK0317G27A	KIT, CARTER + SPACERS KIT CARTER + DISTANZIALI КОЖУХ В КОМПЛЕКТЕ С ПРОСТАВКАМИ	KIT CARTER + ENTRETOISES KIT CARTER + DISTANCIADORES	SATZ GEHÄUSE + DISTANZSTÜCKE KIT CÂRTER + DISTANCIAS	1	COLUMN		X	
5	EAC0114G10A	PLASTIC COVER FOR TILTING TOWER CARTER SUP. COLONNA RIBALTABILE КОЖУХ КОЛОННЫ ПЛАСТИКОВЫЙ	CARTER SUP. COLONNE RABATTABLE CARTER SUP. COLUMNA GIRATORIA	OB. GEHÄUSE KIPPSÄULE CÂRTER SUP. COLUNA BASCULÁVEL	1			X	
6	EAK0317G25A	KIT, FIXING FOR CARTER KIT FISSAGGIO CARTER КОМПЛЕКТ КРЕПЛЕНИЯ КОЖУХА	KIT FIXATION CARTER KIT FIJACIÓN CARTER	BEFESTIGUNGSSATZ GEHÄUSE KIT FIXAÇÃO CÂRTER	1			X	
7	EAK0306G39A	SCREWS FOR UPPER LOCKING LEVER KIT VITI STRANGOLO SUPERIORE ВИНТЫ КРЕПЛЕНИЯ ПЛАСТИНЫ БЛОКИРОВ	KIT VIS BLOCAGE SUPERIEUR KIT TORNILLOS ESTRANGULADOR SUPERIOR	SCHRAUBENSATZ OBERER KLEMMHEBEL KIT PARAFUSOS ENFORC. SUPERIOR	1	UNI5931-67	X		
8	EAM0074G94A	LEVER, PLATE-UPPER LEVA STRANGOLO SUPERIORE ПЛАСТИНА БЛОКИРОВКИ	LEVIER PLAQUETTE SUPERIEURE PALANCA PLAQUETA SUPERIOR	HEBEL ALAVANCA ENFORC. SUPERIOR	1		X		
9	EAC0099G86A	CARTER, HOSES PROTECTION CARTER PROTEZIONE TUBI КОЖУХ ЗАЩИТЫ ПНЕВМОШЛАНГОВ	CARTER PROTECTION TUYAUX CÂRTER PROTECCIÓN TUBOS	FLANSCH, ABDECKUNG F. LEITUNGEN CÂRTER PROTEÇÃO TUBOS	1		X		
10	1-14701A	SCREW HEX HEAD MACHINE 6X16 8G VITE TE SCREW	VIS H TORNILLO TE	SCHRAUBE TE 6X16 8G PARAFUSO TE	2	6X16 8G UNI 5739	X		
11	1-61009A	SCREW VITE ВИНТ	VIS TORNILLO	SCHRAUBE PARAFUSO	1	M4x25 ISO 7380	X		
12	1-13241	WASHER,FLAT, d.6 RONDELLA PIANA d.6 BR ШАЙБА 06	RONDELLE DIAM 6 ARANDELA PLANA D.6 BR	SCHEIBE D.6 ARRUELA	3		X		
13	1-01637A	NUT-S.LOCK,HIGH - M6 5S DADO M6 AUT.ALTO CL6 ANEL.PLAS.B ГАЙКА САМОКОНТРЯЩАЯСЯ M6 6S	ECROU AUTOB.HAUT M6 5S TUERCA M6 AUT.ALTO CL6	MUTTER, SELBSTSICHERND M6 PORCA M6 AUT.ALTO CL6 ANEL.PLAS.B	2		X		
14	EAA0338G09A	VALVE,LIFT CONTROL,YELLOW BUTTON VALVOLA COMANDO SOLLEVATORE PULS.GI КЛАПАН УПРАВЛЕНИЯ ПОДЪЕМОМ, ЖЕЛТАЯ	SOUPAPE CONTROLE ELEVATEUR VALVULA MANDO ELEVADOR	VENTIL, LIFTSTEUR VALVULA COMANDO LEVANTADOR BOT.AMAF	1		X	X	
15	EAK0316G10A	KIT HANDLE TILTING TOWER KIT MANIGLIA PALO RIBALTABILE РУКОЯТКА	KIT POIGNEE POTEAU RABATTABLE KIT ASA POSTE ABATIBLE	GRIFFSATZ KIPPSÄULE CONJUNTO MANÍPULO TORRE VIRÁVEL	1			X	
16	1-17909	SCREW- TCEI 8X30 8G VITE TCEI ВИНТ TCEI M8X30	VIS Chc TORNILLO TCEI	ZYLINDERSCHR.B.M.ISKT. M8X25 8.8 A2J PARAFUSO TCEI	1		X		
17	1-10041	WASHER D.8 RONDELLA P.D.8 Z.BIANCA ШАЙБА D 8	RONDELLE DIAM 8 ARANDELA PLANA D.8 GALVANIZ.	SCHEIBE B 8,4 -A2J ARRUELA P.D.8 Z.BRANCA	3	D8-UNI6592-69 DIN 125	X		

A = available - disponible - vorhanden - beschikbaar
= disponibile - disponible - disponivel - Доступно

B = on request - sur demande - auf Antrag - op aanvraag
= a richiesta - a petición - no pedido - По запросу

C = suggested - suggeré - vorgeschlagene - aanbevolen
= consigliato - sugerido - sugerido - Предлагается

Pos	Code	Designation Designazione ОПИСАНИЕ	Désignation Designación	Bezeichnung Designação	N.	Note Nota HOTa	A	B	C
18	EAM0082G49A	CYLINDRE, LIFT CILINDRO SOLLEVATORE ЦИЛИНДР	CYLINDRE ÉLEVATEUR CILINDRO ELEVADOR	ZYLINDER 3300 RACING CILINDRO LEVANTADOR	1		X		X
19	EAM0082G53A	UPPER CAP, VERTICAL ROD COPERCHIO SUP.ASTA VERTICALE КОЖУХ ВЕРХНИЙ ШТАНГИ	COUVERCLE SUPERIEUR, TIGE VERTICAL TAPA SUPERIOR ASTA VERTICAL	UPPER CAP, VERTICAL ROD COBERTURA SUP.HASTE VERTICAL	1		X		
20	EAM0082G55A	CYLINDER CHAMBER CAMERA CILINDRO SOLLEVATORE ЦИЛИНДР	CHAMBRE CYLINDRE ELEVATEUR CÂMARA CILINDRO ELEVADOR	KAMMER HUBZYLINDER CÂMERA CILINDRO ELEVADOR	1		X		
22	EAC0102G31A	SEAL, OR GUARNIZIONE OR МАНЖЕТА	JOINT TORIQUE JUARNICIÓN OR	DICHTUNG VEDAÇÃO, OR	1		X		
23	EAM0043G68A	VERTICAL ROD CH38 ASTA VERTICALE CH38 ШТАНГА ВЕРТИКАЛЬНАЯ CH38	TIGE VERTICALE CH38 BARRA VERTICAL CH38	SECHSKANTSTANGE HASTE VERTICAL CH38	1		X		
24	EAC0094G01A	SHOCK ABSORBER- ROD AMMORTIZZATORE ASTA ST.1235 АМОТИЗАТОРНОЕ КОЛЬЦО	AMORTISSEUR- TIGE ST1235 AMORTIGUADOR ASTA	STOSSDÄMPFER F. STANGE ST.1235 AMORTECEDOR HASTE ST.1235	1		X		
25	EAA0329G95A	MOUNTING/DEMOUNTING TOOL UTENSILE AUTO COMPLETO "ACCESSORIO" МОНТАЖНАЯ ГОЛОВКА	OUTIL P. MONTAGE ET DEMONTAGE HERRAMIENTA P. MONTAJE Y DESMONTAJE	MONTIER / AUSBAUWERKZEUG FERRAM. AUTO COMPLETO "ACESSÓRIO"	1		X		
26	EAM0032G02A	WASHER- TOOL CLAMPING RONDELLA FISSAG.UTENS. ШАЙБА КРЕПЛЕНИЯ МОНТАЖНОЙ ГОЛОВКИ	RONDELLE FIXATION OUTIL ARANDELA BLOQUEO HERRAMIENTA	SCHEIBE ARRUELA FIXAÇÃO FERR.ZINC. BRANCA	1		X		
27	1-34301A	SCREW HEX 10X20 8G VITE TE ВИНТ 10X20 8G	VIS H TORNILLO TE	SCHRAUBE HEX 10X20 PARAFUSO TE	1		X		
28	EAA0372G24A	PROTECTIONS FOR MOUNTING TOOLS GRUPPO PROTEZIONI UNIFICATE PER UTENSILI КОМПЛЕКТ ЗАЩИТНЫХ ВСТАВОК	PROTECTIONS FOR MOUNTING TOOLS GRUPO PROTECCIONES UNIFICADAS PARA HERRAMIENTAS	GENORMTE SCHUTZEINRICHTUNGEN FÜR WERKZEUGE CONJUNTO PROTEÇÕES UNIFICADAS PARA FERRAMENTAS	1		X		X
29	EAA0344G32A	CYLINDER- VERTICAL, LOCKING CILINDRO BLOCCAGGIO VERTICALE ПНЕВМОЦИЛИНДР ВЕРТИКАЛЬНОЙ БЛОКИРОВКИ	VERIN- BLOCAGE VERTICAL CILINDRO BLOQUEO VERTICAL	ZYLINDER-VERTIKALE KLEMMUNG CILINDRO TRAVAGEM VERTICAL *	1		X		X
30	1-17209	SCREW TCEI 6X60 8G VITE TCEI ВИНТ TCEI 6X60 8G	VIS CHc TORNILLO TCEI	ZYL.SCHR. INNENS. 6X60 8.8 A2R UNI5931 PARAFUSO TCEI	1	6X60 8G	X		
31	EAL0408G42A	STICKER DANGER TARGA DANGER НАКЛЕЙКА ОПАСНОСТЬ	PLAQUETTE DANGER ADHESIVO PELIGRO	GEFAHRENSCHILD PLACA PERIGO	2		X		
32	EAM0082G43A	ROLLER, ARM SLIDING RULLO SCORRIMENTO BRACCIO ROLLER, ARM SLIDING	ROULEAU GLISSEMENT BRAS CILINDRO DESPLAZIAMENTO BRAZO	LAUFWALZE ARM ROLO ESCORRIMENTO BRAÇO	1			X	
33	1-55101A	SCREW M8X1X12 BURNISHED UNI 5923 VITE STEI ВИНТ M8X12 ПОЛИРОВАННЫЙ	VIS FHc TORNILLO STEI	GEWINDESTIFT M8X1X12 BR P.P 12.9 UNI 5923 PARAFUSO STEI	4		X		
34	EAM0082G44A	KICKOFF ESPULSORE FORMA D" 7,8XL100 ОСЬ РОЛИКА	EXPULSOR EXPULSOR	KICKOFF EXPULSOR FORMA D" 7,8XL100	1			X	
35	EAK0306G83A	FRONT COLUMN PROTECTION KIT KIT CARTER ANTERIORE PALO КОМПЛЕКТ ПЕРЕДНИЙ КОЛОННЫ ЗАДНИЙ	KIT CARTER AVANT POTENCE KIT CÂRTER ANTERIOR POSTE	SET FÜR VORDERES GEHÄUSE D. SÄULE KIT CÂRTER ANTERIOR COLUNA	1		X		

A = available - disponible - vorhanden - beschikbaar
= disponibile - disponible - disponivel - Доступно

B = on request - sur demande - auf Antrag - op aanvraag
= a richiesta - a petición - no pedido - По запросу

C = suggested - suggeré - vorgeschlagene - aanbevolen
= consigliato - sugerido - sugerido - Предлагается

Pos	Code	Designation Designazione ОПИСАНИЕ	Désignation Designación	Bezeichnung Designação	N.	Note Nota HOTa	A	B	C
36	EAK0306G50A	Ø12 FULCRUM KIT KIT FULCRO Ось 012	KIT PIVOT Ø12 KIT PERNO Ø12	SET DREHPUNKT Ø12 KIT FULCRO	1		X		
37	EAC0103G39A	BASE COLUMN PLASTIC COVER COPERTURA BASE PALO RIBALT. ПЛАСТИК. КОЖУХ ОПОРЫ КОЛОННЫ	HABILLAGE BASE POTENCE BASC. COBERTURA BASE POSTE ABATIBLE	UNTERES GEHÄUSE KIPPSÄULE COBERTURA BASE COLUNAVIR.	1		X		
38	1-19041A	WASHER 5X16X1 RONDELLA COMUNE 5X15X1,5 BRUN ШАЙБА 5X16X1	RONDELLE 5X16X1 BRUNIE ARANDELA 5X16X1	SCHEIBE 5X16X1 ARRUELA COMUM 5X15X1,5 BRUM	4		X		
39	1-24223A	SCREW- SELFTHREAD. 10EX16 TE VITE AUTOFIL. ВИНТ САМОНАРЕЗАЮЩИЙ	VIS AUTOTAR. TORNILLO AUTOF.	SCHRAUBE 10EX16TE PARAFUSO AUTO-ROSC.	4		X		
40	EAK0306G49A	COLUMN END STROKE KIT KIT FINE CORSA PALO ОГРАНИЧИТЕЛЬ ХОДА КОЛОННЫ	KIT FIN DE COURSE POTENCE KIT FINAL DE CARRERA POSTE	SET ENDANSCHLAG SÄULE KIT LIMITADOR DE CURSO COLUNA	1		X		
41	1-18084A	GREASER-NIPPLE M8x1,25 INGRASSATORE DIRITTO M8x1,25 МАСЛЕНКА М8	GRAISSEUR A BILLES ENGRASADOR A ESFERA M8x1,25	SCHMIERNIPPEL M8x1,25 LUBRIFICADOR RETO M8x1,25 7663-A CH=9	1	7663-A CH=9	X		
42	EAS2111G04A	BRACKET FOR TILTING TOWER, WHITE ZINC ORECCHIA PER RIBALTABILE КРОНШТЕЙН ЦИЛИНДРА УПРАВЛЕНИЯ КОЛС	OREILLE POUR BASCULANTE OREJA PARA ABATIBLE	HALTER FÜR KIPPSÄULE ORELHA FIXADOR VIRÁVEL ZINCADA BRANCA	2		X		
43	EAA0356G14A	CYLINDER TILTING TOWER CILINDRO PALO RIBALTABILE ЦИЛИНДР УПРАВЛЕНИЯ КОЛОННОЙ	VERIN POTENCE BASCULANTE CILINDRO POSTE VOLCABLE	ZYLINDER KIPPSÄULE CILINDRO COLUNAVIRÁVEL	1		X		
44	1-21501	SCREW TE 12X140 8G VITE TE ВИНТ TE 12X140 8G	VIS H TORNILLO TE	SECHSKANTSCHRAUBE 12X140 10.9 BR UNI : PARAFUSO TE	1	M112X140 8G	X		
45	EAM0069G66A	SPACER FOR CYLINDER Distanziale ORECCHIE CILINDRO ZINC.BIA ПРОСТАВКА ЦИЛИНДРА	ENTRETOISE OREILLES VERIN ZINC.BLANC DISTANCIADOR OREJAS CILINDRO GALV. BLA	DISTANZSTÜCK F. ZYLINDER, WEISS VERZIN DISTANCIADOR ORELHAS CILINDRO ZINC.BR/	1		X		
46	1-19933A	NUT - LOCK - M12 DIN985 DADO M12 AUT.BASSO ГАЙКА КОНТРЯЩАЯ M12	ECROU AUTOBLOQUANT M12 TUERCA M12 AUTOBLOQUEO CL6	SECHSKANTMUTTER M 12 -8-A2J PORCA M12 AUT.BAIXO CL6	1		X		
47	EAA0356G43A	SEALS,KIT FOR TILTING-TOWER CYLINDER D KIT GUARNIZIONI CILINDRO RIBAL. D.90 КОМПЛЕКТ МАНЖЕТ ПНЕВМОЦИЛИНДРА 090	KIT JOINTS VERIN BASCULEMENT D.90 KIT JUNTAS CILINDRO ABATIBLE D.90	DICHTUNGSSATZ KIPPZYLINDER D.90 KIT GUARNIÇÕES CILINDRO VIRÁVEL	1		X	X	
48	EAK0306G02A	TILTING TOWER CONNECTING KIT KIT COLLEGAMENTO PALO RIBALTABILE КОМПЛЕКТ КРЕПЛЕНИЯ ОТКИДНОЙ КОЛОНН	KIT RACORDEMENT POTENCE BASCULANTE KIT CONEXIÓN POSTE PLEGABLE	ANSCHLUSSSET KIPPSÄULE KIT LIGAÇÃO COLUNAVIRÁVEL	1		X		
49	EAK0306G35A	CLAMP OVERTURNING KIT KIT FERMO PALO RIBALTABILE ОГРАНИЧИТЕЛЬ	KIT ARRET POTENCE BASCULANTE KIT TOPE POSTE PLEGABLE	STOPPERSET KIPPSÄULE KIT FIXADOR COLUNAVIRÁVEL	1	UNI 5737-65	X		
50	EAM0080G77A	TOWER SUPPORT MACHINED SUPPORTO PALO LAVORATO ДЕРЖАТЕЛЬ КОЛОННЫ	SUPPORT POTENCE SOPORTE POSTE MECANIZADO	BEARBEITETE SÄULENSTÜTZE SUPORTE COLUNATRABALHADO	1		X		
51	EAK0306G37A	SCREWS+BOLTS FOR COLUMN SUPPORT KIT VITI SUPPORTO PALO КОМПЛЕКТ КРЕПЛЕНИЯ ДЕРЖАТЕЛЯ КОЛОН	KIT VIS SUPPORT POTENCE KIT TORNILLOS SOPORTE POSTE	SCHRAUBENSET SÄULENSTÜTZE KIT PARAFUSOS SUPORTE COLUNA	1		X		
52	EAK0306G51A	REAR COLUMN PROTECTION KIT KIT CARTER POSTERIORE PALO КОМПЛЕКТ ЗАЩИТЫ КОЛОННЫ ЗАДНИЙ	KIT CARTER ARRIERE POTENCE KIT CÂRTER POSTERIOR POSTE	SET FÜR HINTERES GEHÄUSE D. SÄULE KIT CÂRTER POSTERIOR COLUNA	1	UNI 5933-67	X		

A = available - disponible - vorhanden - beschikbaar
= disponibile - disponible - disponível - Доступно

B = on request - sur demande - auf Antrag - op aanvraag
= a richiesta - a petición - no pedido - По запросу

C = suggested - suggeré - vorgeschlagene - aanbevolen
= consigliato - sugerido - sugerido - Предлагается

Pos	Code	Designation Designazione ОПИСАНИЕ	Désignation Designación	Bezeichnung Designação	N.	Note Nota NOTa	A	B	C
53	EAK0306G38A	LABEL KIT FOR COLUMN KIT TARGHE PALO НАКЛЕЙКА КОЛОННЫ	KIT PLAQUETTES POTENCE KIT PLACAS POSTE	SET MIT SÄULENSCHILDERN KIT PLACAS COLUNA	2			X	
54	EAC0102G53A	PROTECTION, CYLINDER CARTER CHIUSURA CILINDRO КОЖУХ ПНЕВМОЦИЛИНДРА	PROTECTION VERIN PROTECCIÓN CILINDRO	ZYLINDERABDECKUNG CÁRTER FECHAM. CILINDRO DESMONT.1799	1			X	
55	EAA0344G48A	CYLINDER - ROD,HORIZONTAL-LOCK CILINDRO BLOCCAGGIO ORIZZONT. ЦИЛИНДР ГОРИЗОНТАЛЬНОЙ БЛОКИРОВКИ	VERIN- BLOCAGE HORIZONTAL CILINDRO BLOQUEAJE ORIZONTAL	ZYLINDER-WAAGER. KLEMMUNG CILINDRO TRAVAGEM HORIZONT.	1			X	
56	EAK0306G48A	SCREWS FOR REAR LOCKING LEVER KIT VITI STRANGOLO POSTERIORE ВИНТЫ КРЕПЛЕНИЯ ПЛАСТИНЫ БЛОКИРОВ	KIT VIS BLOCAGE ARRIERE KIT TORNILLOS ESTRANGULADOR POSTERIO	SCHRAUBENSATZ HINTERER KLEMMHEBEL KIT PARAFUSOS ENFORC. POSTERIOR	1	UNI 6592-69		X	
57	EAM0074G95A	LEVER, LOCKING LEVA STRANGOLO ПЛАСТИНА БЛОКИРОВКИ	LEVIER DE BLOCAGE PALANCA DE BLOQUEAJE	HEBEL ALAVANCA ENFORC.	1			X	
58	EAC0094G00A	SCREW-ARM,RETAINING VITE ARRESTO BRACCIO ВИНТ РЫЧАГА	VIS ARRET BRAS TORNILLO DE PARO BRAZO	SCHRAUBE PARAFUSO PARADA BRAÇO	1				X
59	EAC0113G86A	SPACER FOR AIR HOSES PROTECTION Distanziale FISSAGGIO PROTEZIONE TUBI ПРОСТАВКА	ENTRETOISE DISTANCIADOR	DISTANZSTÜCK DISTANCIADOR	1			X	
60	EAK0306G36A	SHOCK ABSORBER KIT FOR COLUMN KIT TAMPONI AMMORTIZZTORE PALO КОМПЛЕКТ АМОТИЗАТОРОВ КОЛОННЫ	KIT TAMPONS AMORTISSEUR POTENCE KIT TAMPONES AMORTIGUADOR POSTE	PUFFERSATZ SÄULENSTOSSDÄMPFER KIT TAMPÕES AMORTECEDOR COLUNA	1	DIN 985		X	

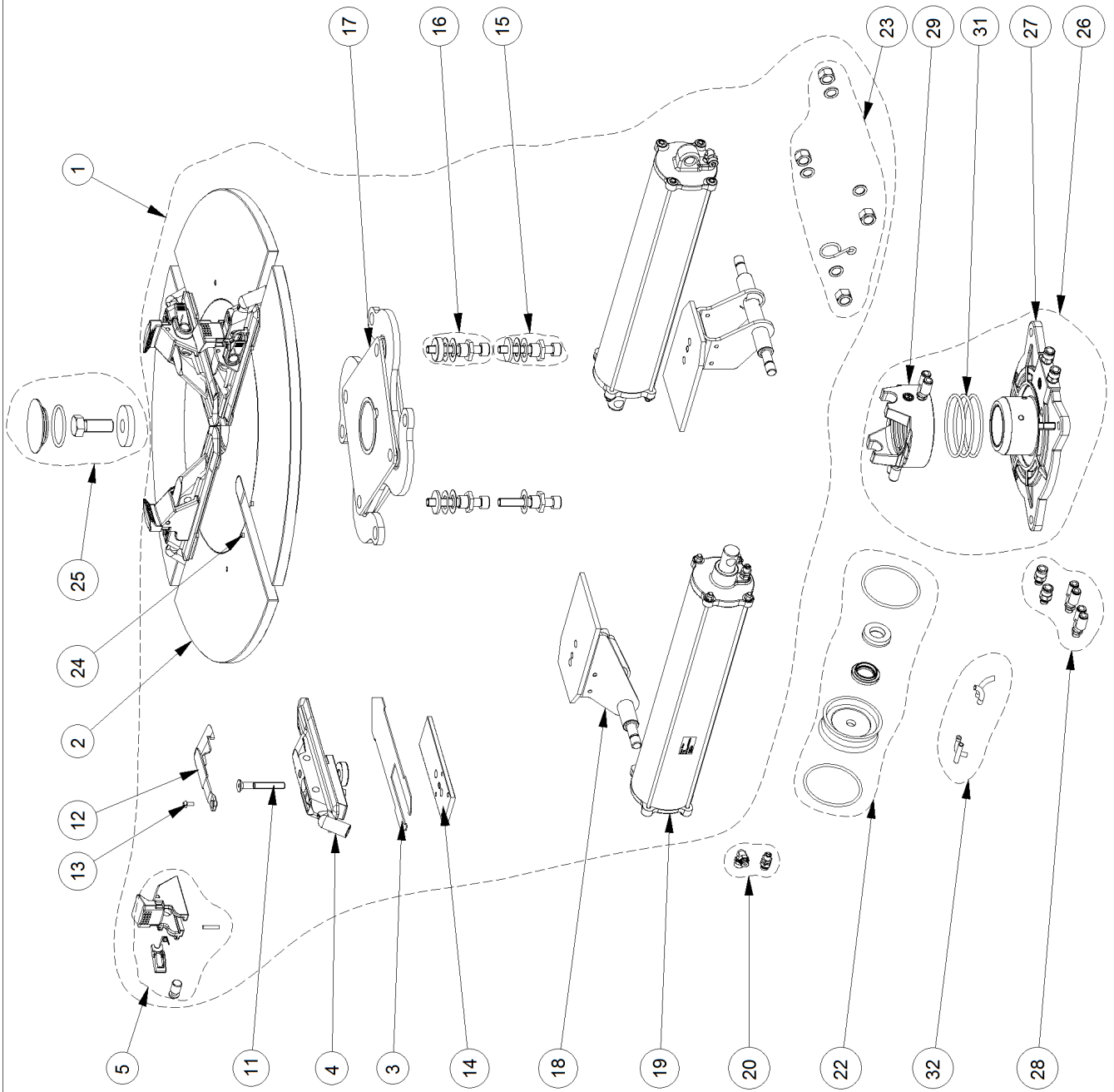

Pos	Code	Designation Designazione ОПИСАНИЕ	Désignation Designación	Bezeichnung Designação	N.	Note Nota HOTa	A	B	C
1	EAA0409G84A	TURNTABLE 24 AUTOCENTRANTE 24" C/CENTRO SCORREVC ПОВОРОТНЫЙ СТОЛ 24"	AUTOCENTRANT 24" AVEC CENTRE COULISS/ AUTOCENTRANTE 24" C/CENTRO DESLIZANTE	SPANNVORRICHTUNG 24" KONV./MITTE LAUF AUTOCENTRALIZADOR 24" C/CENTRO DESLIZ	1		X		
2	EAS2153G40A	PLATE- TURNTABLE, CENTRAL 20" FLANGIA AUTOCENTRANTE CEN 20" ПЛИТА ПОВОРОТНОГО СТОЛА 20", СООСНЫИ	BRIDE AUTOCENTRANTE CEN 20" BRIDA AUTOCENTRANTE CEN 20"	FLANSCH SPANNVORRICHTUNG KONV./MI FLANGE AUTOCENTRALIZADOR CEN 20"	1		X		
3	EAM0051G00A	GUIDE TERMINALS. CENTRE CONVERG. GUIDA MORS. SCORREV. C.CENTRO НАПРАВЛЯЮЩАЯ	GUIDE BORNES, CONV. CENTRE GUÍA BORNES CONV. CENTRO	LANGLOCHABDECKUNG GUIA GARRA CORREDIÇA C.CENTRO	4		X		
4	EAM0075G00A	CLAMP, SLIDING W/CENTRE 20"-S2-MACHINE MORSETTO SCORR. C/CENTRO 20"-S2-LAVOf ПОЛЗУН, СООСНЫЙ СТОЛ 20"-S2	ETAU COULISSANT A/CENTRE 20"-S2 ABRAZADERA CORREDERA C/CENTRO 20"-S2	SPANNSCHUH-VERSCHIEBBARE KLAUEN AB (I GARRA CORRED. C/CENTRO 20"-S2-TRABALH	4		X		
5	EAA0408G23A	ASSEMBLED SLIDING JAW C/TYPE V2 CUNEO SCORREVOLE C/C ASSEMBLATO V2 КУЛАЧОК ЗАЖИМНОЙ В СБОРЕ ТИП C V2	CALE COULISSANTE C/C ASSEMBLEE V2 CUÑA DESLIZANTE C/C MONTADO V2	GLEITKEIL KONV./MITTE MONTIERT V2 CUNHA DESLIZANTE C/C MONTADO V2	4		X		
11	1-24603A	SCREW TSEI 8X60 12.9 VITE TSEI ВИНТ TCEI M8X60	VIS Fhc TORNILLO TSEI	SCHRAUBE TSEI 8X60 PARAFUSO TSEI	4	M8X60 "12,9 ZINC"	X		
12	EAC0099G90A	PROTECTION JAWS NEW PROTEZIONE MORSETTI NEW ЗАЩИТА КУЛАЧКА НОВ.	PROTECTION ETAUX PROTECCIÓN ABRAZADERA NUEVO ST.	SCHUTZSPANNBACKEN PROTEÇÃO BORNES NEW	4		X		X
13	1-36109A2	SCREW TBEI 5X10 8G VITE TBEI ВИНТ M5X10	VIS Bhc TORNILLO TBEI	SCHRAUBE TBEI 5X10 8G PARAFUSO TBEI	4	5x10 ISO 7380	X		
14	EAM0043G49A	PLATE, REGISTER -CLAMP PIASTRA GUIDA MORSETTO ZINC. BIANCA НИЖНЯЯ ПЛАСТИНА ПОЛЗУНА	PLATEAU REGLAGE ETAU PLATO REGLAJE GARRA	SPANNKLAUENUNTERTEIL PLACA	2		X		
15	EAK0329G89A	SCREWS AND BOLTS FOR CLAMPS KIT VITI PIASTRA COMANDO MORSETTI ВИНТЫ И БОЛТЫ КРЕПЛЕНИЯ	KIT VIS PLATEAU COMMANDE BORNES KIT TORNILLOS PLACA MANDO BORNES	SCHRAUBENSATZ STEUERPLATTE SPANNKL/ KIT PARAFUSOS PLACA COMANDO GRAMPOS	2		X		
16	EAK0329G88A	SCREWS AND BOLTS WITH ECCENTRIC KIT VITI CON ECCENTRICO PIASTRA MORSEI БОЛТЫ И ВИНТЫ ЭКСЦЕНТРИКОВЫЕ	KIT VIS AVEC EXCENTRIQUE PLAQUE BORNE KIT TORNILLOS CON EXCÉNTRICO PLACA BOI	SCHRAUBENSATZ M/EXZENTER PLATTE SPAI KIT PARAFUSOS COM EXCÊNTRICO PLACA G,	2		X		
17	EAA0351G73A	CLAMPING PLATE PIASTRA COMADO MORSETTI ПРИЖИМНОЙ ФЛАНЕЦ	PLAQUE DE FIXATION PLACA MANDO BORNES	KLEMMENPLATTE CHAPA COMANDO GARRAS	1			X	
18	EAA0377G79A	BRACKET CYLINDERS STAFFA PER CILINDRI ZINC BIANCA КРОНШТЕЙН ЦИЛИНДРА ПОВОРОТНОГО СТО	SIEGE VERINS ESTRIBO CILINDROS	SPANNSCHUHUNTERTEIL, ZYLINDERSEITE PRENDEDOR PARA CILINDROS *ZINC BRANCC	2		X		
19	EAA0410G31A	CYLINDER, TURNTABLE CILINDRO AUTOCENTRANTE ПНЕВМОЦИЛИНДР ПОВОРОТНОГО СТОЛА	CYLINDRE AUTOCENTRANT CILINDRO AUTOCENTRADOR	ZYLINDER SPANNVORRICHTUNG CILINDRO AUTOCENTRALIZADOR	2		X		
20	EAK0330G35A	TIT CYLINDER FITTINGS KIT KIT RACCORDI CILINDRO AUTOCENTRANTE КОМПЛЕКТ ШТУЦЕРОВ ПНЕВМОЦИЛИНДР	KIT RACCORDS CYLINDRE AUTOCENTRANT KIT RACORES CILINDRO AUTOCENTRADOR	SATZ ANSCHLÜSSE F/ZYL. SPANNVORRICHTL KIT JUNÇÕES CILINDRO AUTOCENTRALIZADC	1			X	
22	EAK0317G36A	SEAL SP FOR ROUND CYLINDER KIT RICAMBIO GUARNIZIONI CILINDRI TONDI КОМПЛЕКТ МАНЖЕТ ПНЕВМОЦИЛИНДРА "КР	KIT PIECE DE RECHANGE JOINTS CYLINDRES KIT RECAMBIO JUNTAS CILINDROS REDONDC	ERSATZSCHRAUBENSATZ ZYLINDER RUND KIT REPOSIÇÃO GUARNIÇÕES CILINDROS RE	2		X		X
23	EAK0306G27A	SCREWS AND BOLTS FOR TURNTABLE CYL. KIT VITI CILINDRI AUTOCENTRANTE ГАЙКИ ЦИЛИНДРА ПОВОРОТНОГО СТОЛА	KIT VIS VERINS AUTOCENTRANT KIT TORNILLOS CILINDROS AUTOCENTRADOF	SCHRAUBENSATZ ZYLINDER SPANNVORRICH KIT PARAFUSOS CILINDROS AUTOCENTRALIZ	1		X		

A = available - disponible - vorhanden - beschikbaar
= disponibile - disponible - disponivel - Доступно

B = on request - sur demande - auf Antrag - op aanvraag
= a richiesta - a petición - no pedido - По запросу

C = suggested - suggeré - vorgeschlagene - aanbevolen
= consigliato - sugerido - sugerido - Предлагается

Pos	Code	Designation Designazione ОПИСАНИЕ	Désignation Designación	Bezeichnung Designação	N.	Note Nota NOTa	A	B	C
24	1-25952A	PIN DOWEL 5x10 UNI EN 28734 SPINA ПАЛЕЦ 5X10	GOUILLE PASADOR	STIFT D5x10B PINO	8	5x10	X		
25	EAK0306G25A	TURNTABLE FIXING KIT KIT COLLEGAMENTO AUTOCENTRANTE КОМПЛЕКТ КРЕПЛЕНИЯ ПОВОРОТНОГО СТО	KIT RACCORDAMENTO AUTOCENTRANT KIT CONEXIÓN AUTOCENTRADOR	BEFESTIGUNGSSET SPANNVORRICHTUNG KIT LIGAÇÃO AUTOCENTRALIZADOR	1		X		
26	EAA0371G41A	REVOLVING MANIFOLD DISTRIBUTORE GIREVOLE КОЛЛЕКТОР	DISTRIBUTEUR TOURNANT DISTRIBUIDOR GIRATORIO	DREHVERTEILER DISTRIBUIDOR GIRATÓRIO	1		X		
27	EAA0371G40A	INTERNAL RING ANELLO INTERNO КОЛЬЦО ВНУТРЕННЕЕ	BAGUE INTERNE ANILLO INTERIOR	INNENRING ANEL INTERNO	1		X		
28	EAK0330G29A	REVOLVING MANIFOLD FITTINGS KIT KIT RACCORDI DISTRIBUTORE GIREVOLE КОМПЛЕКТ ШТУЦЕРОВ КОЛЛЕКТОР	KIT RACCORDAMENTO DISTRIBUTEUR TOURNANT KIT RACORES DISTRIBUIDOR GIRATORIO	SATZ ANSCHLÜSSE F/DREHVERTEILER KIT JUNÇÕES DISTRIBUIDOR GIRATÓRIO	1			X	
29	EAM0079G93A	EXTERNAL RING ANELLO ESTERNO КОЛЬЦО ВНЕШНЕЕ	BAGUE EXTERNE ANILLO EXTERIOR	AUSSENRING ANEL EXTERNO	1		X		
31	8-18514A	O-RING N.176 O-RING N.176 КОЛЬЦО N.176	O-RING N.176 O-RING N.176	O-RING N.176 O-RING N.176	3		X		X
32	EAK0317G08A	HOSES KIT FOR 24" TURNTABLES KIT TUBI PER AUTOCENTRANTE 24" КОМПЛЕКТ ПНЕВМОШЛАНГОВ СТОЛА 24"	KIT TUYAUX POUR AUTO-CENTRANT 24" KIT TUBOS PARA AUTOCENTRANTE 24"	SCHLAUCHSATZ SPANNVORRICHTUNG 24" KIT TUBOS PARA AUTOCENTRALIZADOR 24"	1		X		

A = available - disponible - vorhanden - beschikbaar
= disponibile - disponible - disponivel - Доступно

B = on request - sur demande - auf Antrag - op aanvraag
= a richiesta - a petición - no pedido - По запросу

C = suggested - suggeré - vorgeschlagene - aanbevelen
= consigliato - sugerido - sugerido - Предлагается

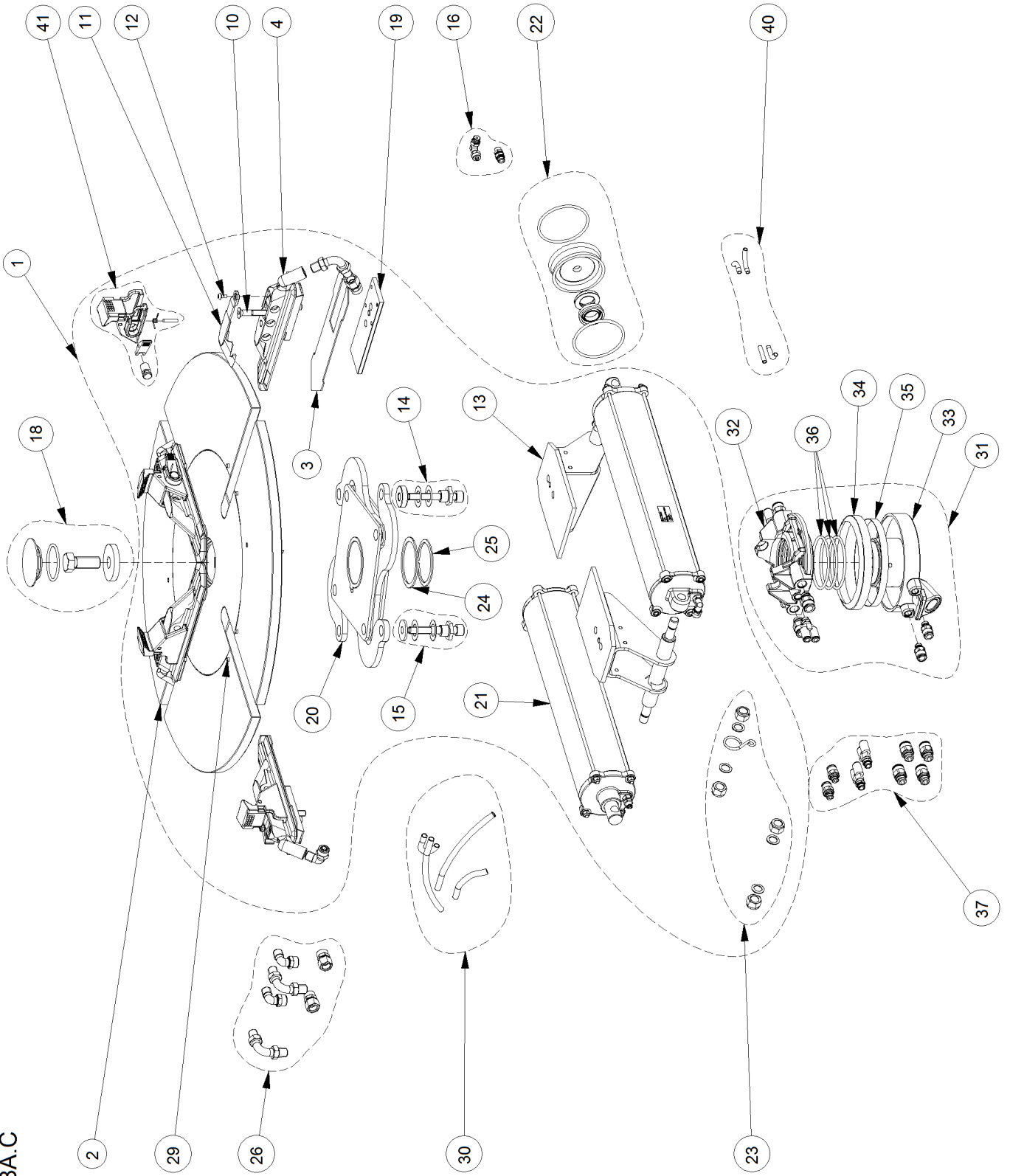

Pos	Code	Designation Designazione ОПИСАНИЕ	Désignation Designación	Bezeichnung Designação	N.	Note Nota HOTa	A	B	C
1	EAA0409G85A	24" TURN TABLE CENTRE TYPE GT AUTOCENTRANTE 24" C/CENT.GT SCORREV ПОВОРОТНЫЙ СТОЛ 24" СООСНЫЙ, ТИП GT	AUTOCENTRANT 24" C/CENT.GT COULISSANT AUTOCENTRANTE 24" C/CENT.GT DESLIZANT	SPANNVORRICHTUNG 24" KONV./MITTE.GT LA AUTOCENTRALIZADOR 24" C/CENT.GT DESLIZ	1		X		
2	EAS2153G40A	PLATE- TURNTABLE,CENTRAL 20" FLANGIA AUTOCENTRANTE CEN 20" ПЛИТА ПОВОРОТНОГО СТОЛА 20", СООСНЫ	BRIDE AUTOCENTRANTE CEN 20" BRIDA AUTOCENTRANTE CEN 20"	FLANSCH SPANNVORRICHTUNG KONV./MI FLANGE AUTOCENTRALIZADOR CEN 20"	1		X		
3	EAM0051G00A	GUIDE TERMINALS. CENTRE CONVERG. GUIDA MORS. SCORREV. C.CENTRO НАПРАВЛЯЮЩАЯ	GUIDE BORNES, CONV. CENTRE GUÍA BORNES CONV. CENTRO	LANGLOCHABDECKUNG GUIA GARRA CORREDIÇA C.CENTRO	4		X		
4	EAM0075G00A	CLAMP, SLIDING W/CENTRE 20"-S2-MACHINE MORSETTO SCORR. C/CENTRO 20"-S2-LAVO ПОЛЗУН, СООСНЫЙ СТОЛ 20"-S2	ETAU COULISSANT A/CENTRE 20"-S2 ABRAZADERA CORREDERA C/CENTRO 20"-S2	SPANNSCHUH-VERSCHIEBBARE KLAUEN AB (C) GARRA CORRED. C/CENTRO 20"-S2-TRABALH	4		X		
10	1-24603A	SCREW TSEI 8X60 12.9 VITE TSEI ВИНТ TSEI M8X60	VIS FHc TORNILLO TSEI	SCHRAUBE TSEI 8X60 PARAFUSO TSEI	4	M8X60 "12,9 ZINC"	X		
11	EAC0099G90A	PROTECTION JAWS NEW PROTEZIONE MORSETTI NEW ЗАЩИТА КУЛАЧКА НОВ.	PROTECTION ETAUX PROTECCIÓN ABRAZADERA NUEVO ST.	SCHUTZSPANNBACKEN PROTEÇÃO BORNES NEW	4		X		X
12	1-36109A2	SCREW TBEI 5X10 8G VITE TBEI ВИНТ M5X10	VIS BHc TORNILLO TBEI	SCHRAUBE TBEI 5X10 8G PARAFUSO TBEI	4	5x10 ISO 7380	X		
13	EAA0377G79A	BRACKET CYLINDERS STAFFA PER CILINDRI ZINC BIANCA КРОНШТЕЙН ЦИЛИНДРА ПОВОРОТНОГО СТО	SIEGE VERINS ESTRIBO CILINDROS	SPANNSCHUHUNTERTEIL, ZYLINDERSEITE PRENDEDOR PARA CILINDROS *ZINC BRANCO	2		X		
14	EAK0329G88A	SCREWS AND BOLTS WITH ECCENTRIC KIT VITI CON ECCENTRICO PIASTRA MORSETT БОЛТЫ И ВИНТЫ ЭКСЦЕНТРИКОВЫЕ	KIT VIS AVEC EXCENTRIQUE PLAQUE BORNE KIT TORNILLOS CON EXCÉNTRICO PLACA BO	SCHRAUBENSATZ M/EXZENTER PLATTE SPAN KIT PARAFUSOS COM EXCÊNTRICO PLACA G	2		X		
15	EAK0329G89A	SCREWS AND BOLTS FOR CLAMPS KIT VITI PIASTRA COMANDO MORSETTI ВИНТЫ И БОЛТЫ КРЕПЛЕНИЯ	KIT VIS PLATEAU COMMANDE BORNES KIT TORNILLOS PLACA MANDO BORNES	SCHRAUBENSATZ STEUERPLATTE SPANNKL/ KIT PARAFUSOS PLACA COMANDO GRAMPOS	2		X		
16	EAK0330G35A	TT CYLINDER FITTINGS KIT KIT RACCORDI CILINDRO AUTOCENTRANTE КОМПЛЕКТ ШТУЦЕРОВ ПНЕВМОЦИЛИНДР	KIT RACCORDS CYLINDRE AUTOCENTRANT KIT RACORES CILINDRO AUTOCENTRADOR	SATZ ANSCHLÜSSE F/ZYL. SPANNVORRICHTU KIT JUNÇÕES CILINDRO AUTOCENTRALIZAD	1			X	
18	EAK0306G25A	TURNTABLE FIXING KIT KIT COLLEGAMENTO AUTOCENTRANTE КОМПЛЕКТ КРЕПЛЕНИЯ ПОВОРОТНОГО СТО	KIT RACCORDAMENTO AUTOCENTRANT KIT CONEXIÓN AUTOCENTRADOR	BEFESTIGUNGSSET SPANNVORRICHTUNG KIT LIGAÇÃO AUTOCENTRALIZADOR	1		X		
19	EAM0043G49A	PLATE, REGISTER -CLAMP PIASTRA GUIDA MORSETTO ZINC. BIANCA НИЖНЯЯ ПЛАСТИНА ПОЛЗУНА	PLATEAU REGLAGE ETAU PLATO REGLAJE GARRA	SPANNKLAUENUNTERTEIL PLACA	2		X		
20	EAA0351G73A	CLAMPING PLATE PIASTRA COMANDO MORSETTI ПРИЖИМНОЙ ФЛАНЕЦ	PLAQUE DE FIXATION PLACA MANDO BORNES	KLEMMENPLATTE CHAPA COMANDO GARRAS	1			X	
21	EAA0410G31A	CYLINDER, TURNTABLE CILINDRO AUTOCENTRANTE ПНЕВМОЦИЛИНДР ПОВОРОТНОГО СТОЛА	CYLINDRE AUTOCENTRANT CILINDRO AUTOCENTRADOR	ZYLINDER SPANNVORRICHTUNG CILINDRO AUTOCENTRALIZADOR	2		X		
22	EAK0317G36A	SEAL SP FOR ROUND CYLINDER KIT RICAMBIO GUARNIZIONI CILINDRI TONDI КОМПЛЕКТ МАНЖЕТ ПНЕВМОЦИЛИНДРА "КР	KIT PIECE DE RECHANGE JOINTS CYLINDRES KIT RECAMBIO JUNTAS CILINDROS REDONDC	ERSATZSCHRAUBENSATZ ZYLINDER RUND KIT REPOSIÇÃO GUARNIÇÕES CILINDROS RE	2		X		X
23	EAK0306G27A	SCREWS AND BOLTS FOR TURNTABLE CYL. KIT VITI CILINDRI AUTOCENTRANTE ГАЙКИ ЦИЛИНДРА ПОВОРОТНОГО СТОЛА	KIT VIS VERINS AUTOCENTRANT KIT TORNILLOS CILINDROS AUTOCENTRADOR	SCHRAUBENSATZ ZYLINDER SPANNVORRICHT KIT PARAFUSOS CILINDROS AUTOCENTRALIZ	1		X		

A = available - disponible - vorhanden - beschikbaar
= disponibile - disponible - disponivel - Доступно

B = on request - sur demande - auf Antrag - op aanvraag
= a richiesta - a petición - no pedido - По запросу

C = suggested - suggeré - vorgeschlagene - aanbevolen
= consigliato - sugerido - sugerido - Предлагается

Pos	Code	Designation Designazione ОПИСАНИЕ	Désignation Designación	Bezeichnung Designação	N.	Note Nota HOTa	A	B	C
24	EAM0051G85A	SUPPORT,RING RONDELLA DI SOSTEGNO КОЛЬЦО	BAGUE DE SOUTIEN ARANDELA DE SOPORTE	HALTERUNG ANEL, SUPORTE	1		X		
25	1-18677A	RING- STOP D.60 ANELLO D'ARRESTO PER ALB.D.60 СТОПОРНОЕ КОЛЬЦО D60	ANNEAU D'ARRET ANILLO DE PARO PARA ÁRBOL D.60	SICHERUNGSRING D.60 DIN 471 ANEL DE PARADA PARA ALB.D.60	1	D60 UNI 7435	X		
26	EAK0330G32A	GT SYSTEM FITTINGS KIT KIT RACCORDI SISTEMA GT ШТУЦЕРЫ ДЛЯ КОМПЛЕКТ GT	KIT RACCORDEMENTS SYSTEME GT KIT CONEXIONES SISTEMA GT	SATZ ANSCHLÜSSE FÜR GT SYSTEM KIT JUNÇÕES SISTEMA GT	1			X	
29	1-25952A	PIN DOWEL 5x10 UNI EN 28734 SPINA ПАЛЕЦ 5X10	GOUPILLE PASADOR	STIFT D5x10B PINO	8	5x10	X		
30	EAK0317G09A	HOSES KIT FOR GT NOZZLES KIT TUBI PER UGELLI GT КОМПЛЕКТ ПНЕВМОШЛАНГОВ ДЛЯ GT	KIT TUYAUX POUR BUSES GT KIT TUBOS PARA BOQUILLAS GT	SCHLAUCHSATZ FÜR GT-DÜSEN KIT TUBOS PARA BICOS GT	1		X		
31	EAA0304G69A	REVOLVING MANIFOLD, TUBELESS INFLATOR DISTRIBUTORE GIREVOLE GT КОЛЛЕКТОР С GT	DISTRIBUTEUR TOURNANT GT DISTRIBUIDOR GIRATORIO GT	DREHANSCHLUß DISTRIBUIDOR GIRATORIO GT	1		X		
32	EAA0338G76A	RING, OUTER - MANIFOLD ANELLO ESTERNO COLLETTORE КОЛЬЦО ВНЕШНЕЕ	COLLIER EXTERIEUR COLLECTEUR ARO EXTERIOR COLECTOR	RING ANEL EXTERNO COLETOR	1		X		
33	EAA0338G27A	RING-INSIDE, WITH SUPPORTS ANELLO INTERNO COLL.CON GRANI КОЛЬЦО ВНУТРЕННЕЕ	COLLIER INTERIEUR AVEC ROULEMEN RUEDA CON CONEXIÓNS	INNENRING MIT HALTERUNG ANEL INTERNO COL.COM PARAFUSOS	1		X		
34	EAC0087G50A	SEAL TUBELESS INFLATOR-FRONT GUARNIZIONE FRONTALE GONFIAT. САЛЬНИК	JOINT FRONTAL GONFLEUR JUARNICIÓN FRONTAL HINCHADOR TUBELES	DICHTUNG GUARNIÇÃO FRONTAL INFLADOR	1		X		X
35	EAA0338G77A	SPRING, JOINT SEALING MOLLA TENUTA GUARNIZIONE ПРУЖИНА МАНЖЕТЫ КОЛЛЕКТОРА	RESSORT RETENUE JOINT MUELLE SUJECIÓN JUNTA	FEDER MOLA, SELAGEM CONJUNTO	1		X		
36	8-10814A	SEAL OR D.69.44X3.53 GUARNIZIONE OR МАНЖЕТА D 69 44X3,53	JOINT TORIQUE JUARNICIÓN OR	DICHTUNG OR D.69,44 X 3,53 VEDAÇÃO OR	3	ø69.44x3.53	X		X
37	EAK0330G28A	REVOLVING MANIFOLD FITTINGS KIT KIT RACCORDI DISTRIBUTORE GIREVOLE КОМПЛЕКТ ШТУЦЕРОВ КОЛЛЕКТОР	KIT RACCORDEMENT DISTRIBUTEUR TOURN/ KIT RACORES DISTRIBUIDOR GIRATORIO	SATZ ANSCHLÜSSE F/DREHVERTEILER KIT JUNÇÕES DISTRIBUIDOR GIRATÓRIO	1			X	
40	EAK0317G08A	HOSES KIT FOR 24" TURNTABLES KIT TUBI PER AUTOCENTRANTE 24" КОМПЛЕКТ ПНЕВМОШЛАНГОВ СТОЛА 24"	KIT TUYAUX POUR AUTO-CENTRANT 24" KIT TUBOS PARA AUTOCENTRANTE 24"	SCHLAUCHSATZ SPANNVORRICHTUNG 24" KIT TUBOS PARA AUTOCENTRALIZADOR 24"	1		X		
41	EAA0408G23A	ASSEMBLED SLIDING JAW C/TYPE V2 CUNEO SCORREVOLE C/C ASSEMBLATO V2 КУЛАЧОК ЗАЖИМНОЙ В СБОРЕ ТИП С V2	CALE COULISSANTE C/C ASSEMBLEE V2 CUÑA DESLIZANTE C/C MONTADO V2	GLEITKEIL KONV./MITTE MONTIERT V2 CUNHA DESLIZANTE C/C MONTADO V2	4		X		

A = available - disponible - vorhanden - beschikbaar
= disponibile - disponible - disponivel - Доступно

B = on request - sur demande - auf Antrag - op aanvraag
= a richiesta - a petición - no pedido - По запросу

C = suggested - suggeré - vorgeschlagene - aanbevelen
= consigliato - sugerido - sugerido - Предлагается

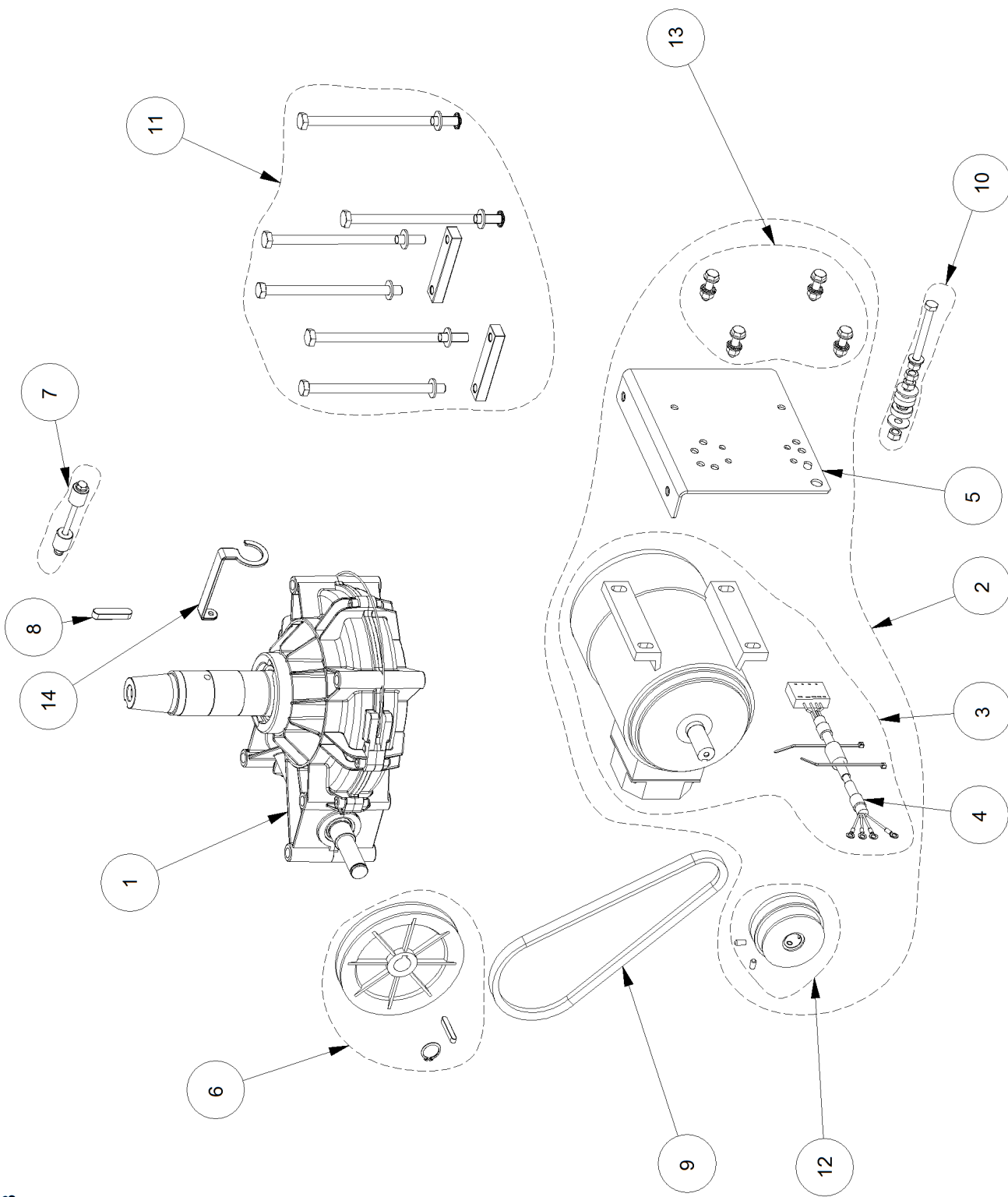

Pos	Code	Designation Designazione ОПИСАНИЕ	Désignation Designación	Bezeichnung Designação	N.	Note Nota HOTa	A	B	C
1	EAA0457G27A	GEARBOX RIDUTTORE РЕДУКТОР	REDUCTEUR REDUCTOR	GETRIEBEGEHÄUSE REDUTOR	1		X		
2	EAA0376G12A	ASSY MOTOR WITH PULLEY 1PH 115V GRUPPO MOTORE CON PULEGGIA 1F 115V D СБОРЕ ДВИГАТЕЛЯ со шкивом 1Ф 115В	GROUPE MOTEUR AVEC POULIE 1F 115V GRUPO MOTOR CON POLEA 1F 115V	EINHEIT MOTOR MIT RIEMENSCHIEBE 1 PH 11 GRUPO MOTOR COM POLIA 1F 115V	1	RIGHT 1PH 115V	X		
2	EAA0410G42A	INVERTER MOTOR ASM GRUPPO MOTORE PER INVERTER ЭЛЕКТРОДВИГАТЕЛЬ ДЛЯ ИНВЕРТЕРА В СБС	GROUPE MOTEUR POUR CONVERTISSEUR GRUPO MOTOR PARA INVERSOR	BAUGRUPPE MOTOR FÜR INVERTER GRUPO MOTOR PARA INVERTER	1		X		
2	EAA0426G32A	INVERTER MOTOR ASM - 200V GRUPPO MOTORE 200V PER INVERTER ЭЛЕКТРОДВИГАТЕЛЬ ДЛЯ ИНВЕРТЕРА В СБС	GROUPE MOTEUR POUR CONVERTISSEUR - 2 GRUPO MOTOR PARA INVERSOR - 200V	BAUGRUPPE MOTOR FÜR INVERTER GRUPO MOTOR PARA INVERTER - 200V	1			X	
3	EAA0371G78A	1PH 115V RIGHT MOTOR CABLE ASM GRUPPO CAVO MOTORE 1F 115V DX КАБЕЛЬ ПРАВОГО ДВИГАТЕЛЯ 1Ф 115В	GROUPE CABLE MOTEUR 1F 115V D GRUPO CABLE MOTOR 1F 115V DER.	EINHEIT MOTORKABEL 1 PH 115V RCHT CONJUNTO CABO MOVIM.R 1F 115V DIR.	1	A	X		
3	EAA0410G01A	HIGH SPEED MOTOR W/CABLE FOR INVERTE MOTORE CON CAVO PER INVERTER HS ЭЛЕКТРОДВИГАТЕЛЬ ВЫС. СКОР. ДЛЯ ИНВЕИ	MOTEUR AVEC CABLE POUR ONDULEUR HS MOTOR CON CABLE PARA INVERTER HS	MOTORKABEL MIT VERBINDER HOCHGESCHV MOTOR COM CABO PARA INVERTER HS	1	CE/JAPAN	X		
3	EAA0438G64A	HIGH SPEED MOTOR W/CABLE 200V MOTORE 200V PER INVERTER HS ЭЛЕКТРОДВИГАТЕЛЬ ВЫС. СКОР. ДЛЯ ИНВЕИ	MOTEUR 200V POUR ONDULEUR HS MOTOR CON CABLE PARA INVERTER HS	MOTORKABEL MIT VERBINDER HOCHGESCHV MOTOR 200V PARA INVERTER HS	1		X		
4	EAW0277G10A	1PH 115V MOTOR CABLE CAVO MOTORE MONOF.115VAC DX NERO КАБЕЛЬ ДВИГАТЕЛЯ 1Ф 115В	CABLE MOTEUR 1F 115VAC CABLE MOTOR 1F 115VCA	MOTORKABEL 1PH 115VAC CABO MOVIM.R 1F 115VAC	1	1PH 115V	X		
4	EAW0282G99A	MOTOR CABLE WITH CONNECTOR CAVO MOTORE CON CONNETTORE КАБЕЛЬ ЭЛЕКТРОДВИГАТЕЛЯ С РАЗЪЕМОМ	CABLE MOTEUR AVEC CONNECTEUR CABLE MOTOR CON CONECTOR	MOTORKABEL MIT VERBINDER CABO MOTOR COM CONECTOR	1	CE/JAPAN	X		
5	EAS2131G28A	MOTOR SUPPORT SUPPORTO MOTORE ДЕРЖАТЕЛЬ ЭЛЕКТРОДВИГАТЕЛЯ	SUPPORT MOTEUR SOPORTE MOTOR	MOTORHALTERUNG SUPORTE MOVIM.R	1		X		
6	EAK0306G14A	REDUCTION UNIT PULLEY KIT KIT PULEGGIA RIDUTTORE ШКИВ РЕДУКТОРА	KIT POULIE REDUCTEUR KIT POLEA REDUCTOR	SET GETRIEBE-RIEMENSCHIEBE KIT POLIA REDUTOR	1		X		
7	EAK0279G67A	ANTIROTATION KIT KIT ANTIROTAZIONE КОМПЛЕКТ ПРОТИВОВРАЩЕНИЯ	KIT ANTIROTATION KIT ANTIRROTACIÓN	KIT DREHSICHERUNG KIT ANTIROTAÇÃO	1		X		
8	1-1572	KEY-10x8x45 LINGUETTA ШПОНКА 10X8X45	LANGUETTE LENGUETA	FEDER 10X8X45 UNI 6604-69 LINGUETA	1	10x8x45	X		
9	EAC0099G95A	BELT, A27 CINGHIA A27 РЕМЕНЬ A27	COURROIE A27 CORREA A27	KEILRIEMEN, A 27 CORREIA A 27	1	A-27	X	X	
9	EAC0078G58A	V BELT, A-26 CINGHIA A-26 РЕМЕНЬ A-26	COURROIE A-26 CORREA A-26	RIEMEN A-26 CORREIA A-26	1	A-26	X	X	
10	EAK0279G66A	BELT TIGHTENER KIT KIT TENDICINGHIA НАБОР НАТЯЖИТЕЛЯ РЕМНЯ	KIT TENDEUR-COURROIE KIT TENSOR DE CORREA	KIT RIEMENSTRAFFER KIT ESTICADOR DE CORREIA	1		X		
11	EAK0279G65A	SCREWS KIT FOR GEARBOX KIT VITI RIDUTTORE КОМПЛЕКТ ВИНТОВ РЕДУКТОРА	KIT VIS REDUCTEUR KIT TORNILLOS REDUCTOR	SCHRAUBEN-KIT GETRIEBEGEHÄUSE KIT PARAFUSOS REDUTOR	1		X		

A = available - disponible - vorhanden - beschikbaar
= disponibile - disponible - disponivel - Доступно

B = on request - sur demande - auf Antrag - op aanvraag
= a richiesta - a petición - no pedido - По запросу

C = suggested - suggeré - vorgeschlagene - aanbevolen
= consigliato - sugerido - sugerido - Предлагается

Pos	Code	Designation Designazione ОПИСАНИЕ	Désignation Designación	Bezeichnung Designação	N.	Note NOTa	Nota	A	B	C
12	EAK0306G15A	MOTOR PULLEY KIT KIT PULEGGIA MOTORE ШКИВ ЭЛЕКТРОДВИГАТЕЛЯ	KIT POULIE MOTEUR KIT POLEA MOTOR	SET ANTRIEBSRIEMENSCHLEIBE KIT POLIA MOVIM.R	1			X		
12	EAM0116G32A	PULLEY DP=2" HOLE D.5/8" PULEGGIA MOTORE DP=2" - FORO D.5/8" ШКИВ DP=2" ОТВЕРСТИЕ D 5/8"	POULIE MOTEUR DP=2" - ORIF. D.5/8" POLEA MOTOR DP=2" - ORIFICIO D.5/8"	RIEMENSCHLEIBE MOTOR DP=2" - BOHRUNG POLIA MOTOR DP=2" - FURO D.5/8"	1	115 V 1PH		X		
13	EAK0279G64A	SCREWS KIT FOR MOTOR KIT VITI MOTORE НАБОР ВИНТОВ ДЛЯ ДВИГАТЕЛЯ	KIT VIS MOTEUR KIT TORNILLOS MOTOR	SCHRAUBEN-KIT MOTOR KIT PARAFUSOS MOVIM.R	1			X		
14	EAS2140G91A	SUPPORT FOR REV. MANIFOLD HOSES SUPPORTO TUBI DISTRIBUTORE ПОДДЕРЖКА РЕВОЛЬВЕРНЫЙ многообразиям	SOUTIEN POUR LES TUYAUX RENEUVELABLE APOYO A GIRATORIO MANGUERAS COLECTO	UNTERSTÜTZUNG FÜR DREH MANIFOLD SCHI APOIO REVOLVENDO HOSES	1	Alu.Rev.Dist.			X	

A = available - disponible - vorhanden - beschikbaar
= disponibile - disponible - disponível - Доступно

B = on request - sur demande - auf Antrag - op aanvraag
= a richiesta - a petición - no pedido - По запросу

C = suggested - suggeré - vorgeschlagene - aanbevolen
= consigliato - sugerido - sugerido - Предлагается

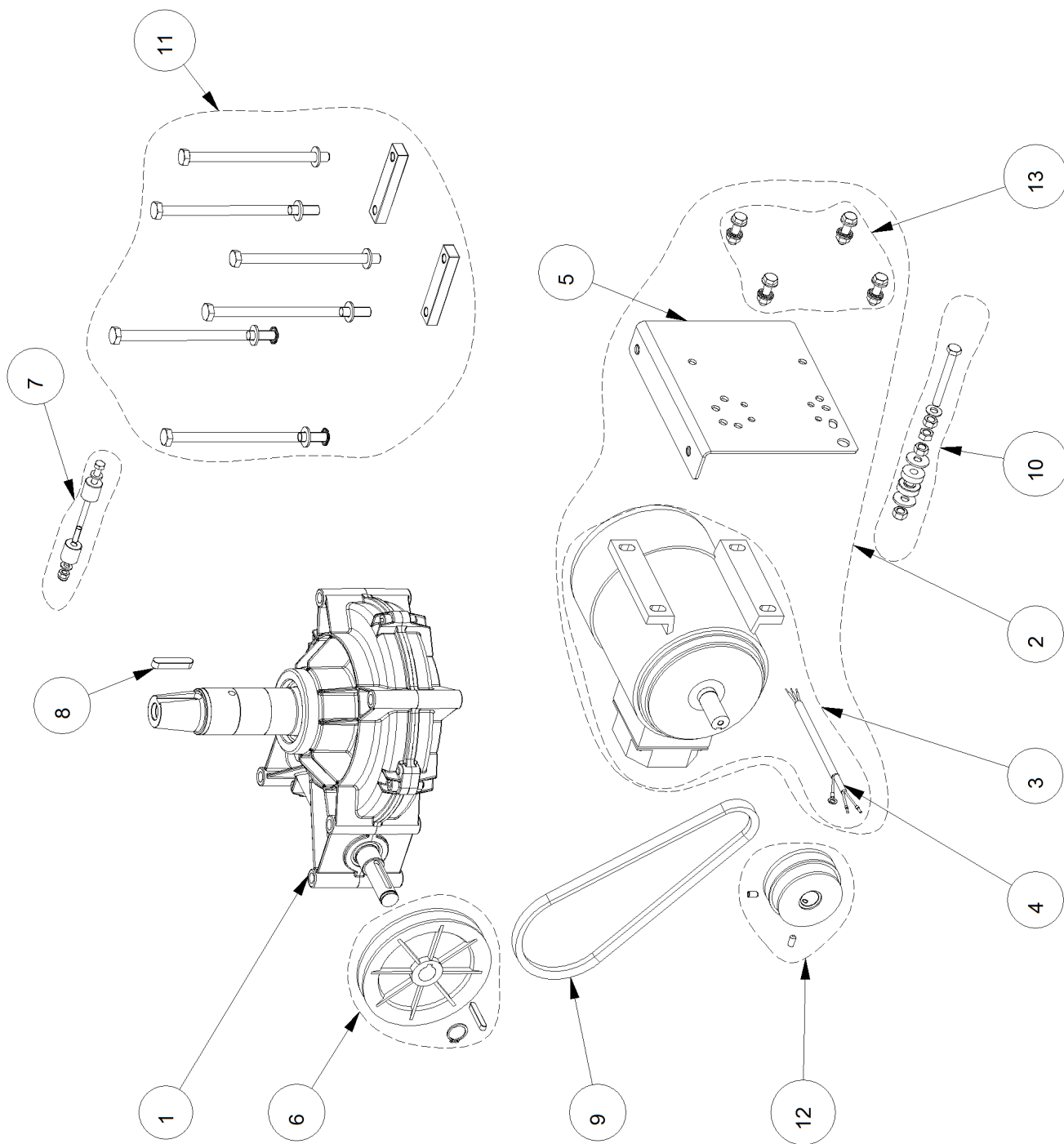

Pos	Code	Designation Designazione ОПИСАНИЕ	Désignation Designación	Bezeichnung Designação	N.	Note Nota	Nota HOTa	A	B	C
1	EAA0457G27A	GEARBOX RIDUTTORE РЕДУКТОР	REDUCTEUR REDUCTOR	GETRIEBEGEHÄUSE REDUTOR	1			X		
2	EAA0410G59A	INVERTER MOTOR ASM GRUPPO MOTORE PER INVERTER - JPN БЛОК ПРИВОДА В СБОРЕ	GROUPE MOTEUR POUR CONVERTISSEUR GRUPO MOTOR PARA INVERSOR	BAUGRUPPE MOTOR FÜR INVERTER GRUPO MOTOR PARA INVERTER	1		JAPAN 18RPM	X		
3	EAA0410G62A	MOTOR WITH CABLE FOR INVERTER MOTORE CON CAVO PER INVERTER ЭЛЕКТРОДВИГАТЕЛЬ С КАБЕЛЕМ ИНВЕРТОР	MOTEUR AVEC CABLE POUR CONVERTISSEUR MOTOR CON CABLE PARA INVERSOR	MOTOR MIT KABEL FÜR INVERTER MOTOR COM CABO PARA INVERTER	1			X		
4	EAW0282G17A	INVERTER-MOTOR CABLE CAVO INVERTER-MOTORE КАБЕЛЬ ЭЛЕКТРОДВИГАТЕЛЯ	CABLE CONVERTISSEUR MOTEUR CABLE INVERSOR-MOTOR	KABEL INVERTER-MOTOR CABO INVERTER-MOTOR	1			X		
5	EAS2131G28A	MOTOR SUPPORT SUPPORTO MOTORE ДЕРЖАТЕЛЬ ЭЛЕКТРОДВИГАТЕЛЯ	SUPPORT MOTEUR SOPORTE MOTOR	MOTORHALTERUNG SUORTE MOVIM.R	1			X		
6	EAK0341G09A	REDUCTION UNIT PULLEY KIT KIT PULEGGIA RIDUTTORE ШКИВ РЕДУКТОРА	KIT POULIE REDUCTEUR KIT POLEA REDUCTOR	SET GETRIEBE-RIEMENSCHIEBE KIT POLIA REDUTOR	1			X		
7	EAK0279G67A	ANTIROTATION KIT KIT ANTIROTAZIONE КОМПЛЕКТ ПРОТИВОВРАЩЕНИЯ	KIT ANTIROTATION KIT ANTIRROTACIÓN	KIT DREHSICHERUNG KIT ANTIROTAÇÃO	1			X		
8	1-1572	KEY-10x8x45 LINGUETTA ШПОНКА 10X8X45	LANGUETTE LENGUETA	FEDER 10X8X45 UNI 6604-69 LINGUETA	1		10x8x45	X		
9	EAC0099G95A	BELT, A27 CINGHIA A27 РЕМЕНЬ A27	COURROIE A27 CORREA A27	KEILRIEMEN, A 27 CORREIA A 27	1		A-27	X		X
10	EAK0279G66A	BELT TIGHTENER KIT KIT TENDICINGHIA НАБОР НАТЯЖИТЕЛЯ РЕМНЯ	KIT TENDEUR-COURROIE KIT TENSOR DE CORREA	KIT RIEMENSTRAFFER KIT ESTICADOR DE CORREIA	1			X		
11	EAK0279G65A	SCREWS KIT FOR GEARBOX KIT VITI RIDUTTORE КОМПЛЕКТ ВИНТОВ РЕДУКТОРА	KIT VIS REDUCTEUR KIT TORNILLOS REDUCTOR	SCHRAUBEN-KIT GETRIEBEGEHÄUSE KIT PARAFUSOS REDUTOR	1			X		
12	EAK0306G15A	MOTOR PULLEY KIT KIT PULEGGIA MOTORE ШКИВ ЭЛЕКТРОДВИГАТЕЛЯ	KIT POULIE MOTEUR KIT POLEA MOTOR	SET ANTRIEBSRIEMENSCHIEBE KIT POLIA MOVIM.R	1			X		
13	EAK0279G64A	SCREWS KIT FOR MOTOR KIT VITI MOTORE НАБОР ВИНТОВ ДЛЯ ДВИГАТЕЛЯ	KIT VIS MOTEUR KIT TORNILLOS MOTOR	SCHRAUBEN-KIT MOTOR KIT PARAFUSOS MOVIM.R	1			X		

A = available - disponible - vorhanden - beschikbaar
= disponibile - disponible - disponivel - Доступно

B = on request - sur demande - auf Antrag - op aanvraag
= a richiesta - a petición - no pedido - По запросу

C = suggested - suggeré - vorgeschlagene - aanbevelen
= consigliato - sugerido - sugerido - Предлагается

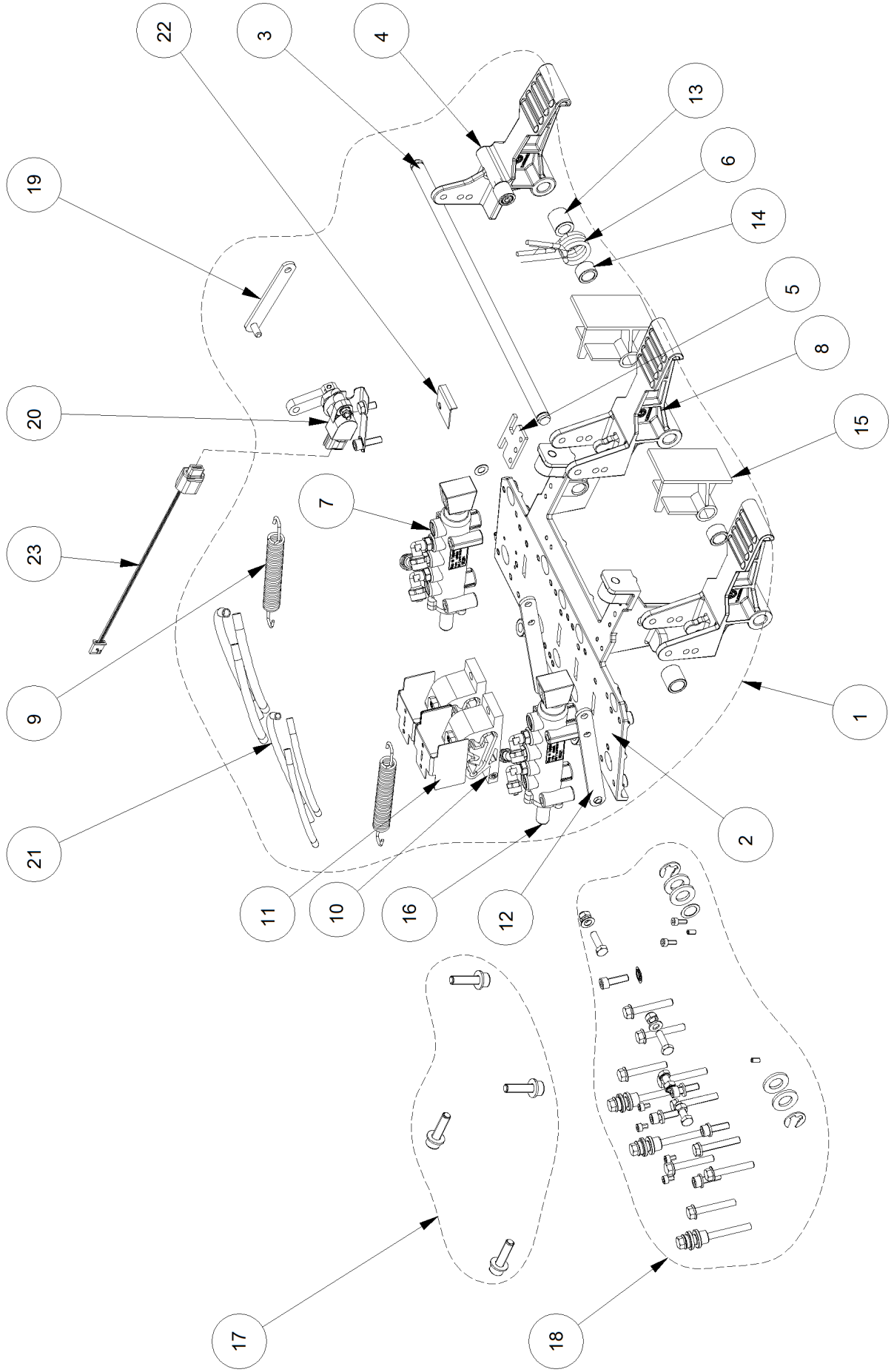

Pos	Code	Designation Designazione ОПИСАНИЕ	Désignation Designación	Bezeichnung Designação	N.	Note Nota HOTa	A	B	C
1	EAA0439G39A	3P CONTROL PEDAL WITH POTENTIOMETER PEDALIERA 3P CON POTENZIOMETRO 3P ПЕДАЛИ С ПОТЕНЦИОМЕТРОМ	PEDALIER 3P AVEC POTENTIOMETRE PEDALERA 3P CON POTENCIÓMETRO	PEDALEINHEIT 3P MIT POTENTIOMETER PEDALEIRA 3P COM POTENCIÓMETRO	1			X	
2	EAM0068G80A	PEDAL ASM SUPPORT - MACHINED SUPPORTO PEDALIERA - LAVORATO ДЕРЖАТЕЛЬ ПЕДАЛИ - МЕХ. ОБРАБОТКА	SUPPORT JEU PÉDALES - USINÉ SOPORTE JUEGO DE PEDALES - MECANIZADO	HALTERUNG PEDALSTEUERUNG - BEARBEITET SUPORTE PEDALEIRA - TRABALHADO	1			X	
3	EAM0068G10A	SHAFT-HINGE, PEDAL PERNO FULCRO PEDALI ШТИФТ ОПОРЫ ПЕДАЛИ СТ.1113/2	PIVOT PEDALES EJE PEDALES	ACHSE, PEDALEINHEIT PINO FULCRO PEDAIS	1		X		
4	EAA0356G92A	RIGHT SWITCH FOOT PEDAL PEDALE SWITCH DX ПЕДАЛЬ ПРАВАЯ	PEDALE INTERRUPTEUR DROIT PEDAL INTERRUPTOR DER.	PEDAL SCHALTER RECHTS PEDAL INTERRP. DIR.	1			X	
5	EAM0070G32A	COMMUTATOR SPRING GUIDE GUIDA MOLLA INVERTITORE ФИКСАТОР ПРУЖИНЫ	GUIDE RESSORT INVERSEUR GUÍ MUELLE INVERTIDOR	FEDERFÜHRUNG INVERTER GUIA MOLA INVERSOR	1		X		
6	EAM0075G56A	SPRING, PEDAL SWITCH 2SPEED MOLLA PEDALE INTERRUPTORE 2SP ПРУЖИНА ПЕДАЛИ ВЫКЛЮЧАТЕЛЯ 2СКОР.	RESSORT INTERRUPTEUR PÉDALE 2SP MUELLE PEDAL INTERRUPTOR 2SP	FEDER PEDALSCHALTER 2SPEED MOLA, INTERRUPTOR PEDAL 2VEL	1			X	
7	EAA0356G94A	VALVE BEAD-BREAKER VALVOLA STALLONATORE КЛАПАН РАЗБОРТОВОЧНОГО УСТРОЙСТВА	VALVE DÉTALONNEUR VÁLVULA DESTALONADOR	ABDRÜCKERVENTIL VÁLVULA DESMONT. PNEU	1		X		X
8	EAM0068G95A	STANDARD PEDAL - MACHINED PEDALE STD - LAVORATO ПЕДАЛЬ СТАНДАРТНАЯ, МЕХ. ОБРАБОТКА	PEDAL STD. PEDAL STD	PEDAL STD. PEDAL PDR - TRABALHADO	2			X	
9	EAM0075G91A	SPRING RECALL PEDALS MOLLA RITORNO PEDALI ПРУЖИНА ВОЗВРАТА ПЕДАЛИ	RESSORT RETOUR PEDALES MUELLE DE RETORNO PEDALES	RÜCKHOLFEDER PEDALE MOLA RETORNO PEDAIS	2		X		
10	EAC0103G56A	CAM FOR PEDAL B CAMMA PEDALE ST.2072 B БЛОК ПЕРЕМЕЩЕНИЯ ПЕДАЛИ B	CAME PEDALE ST.2072 B LEVA PEDAL EST.2072 B	PEDALNOCKEN ST.2072 B CAMES PEDAL ST.2072 B	2		X		
11	EAS2115G09A	PROTECTION SHEET FOR CAM LAMIERA PROTEZIONE CAMMA ЗАЩИТНЫЙ КОЖУХ МЕХАНИЗМА ПЕДАЛИ	TOLE PROTECTION CAME CHAPA PROTECCIÓN EXCÉNTRICO	SCHUTZBLECH NOCKEN CHAPA PROTEÇÃO CAMES	2		X		
12	EAS2111G73A	ROD POSITIONER PEDAL BIELLA POSIZIONATRICE PEDALE ТЯГА ПЕДАЛИ	BIELLE POSITIONNEMENT PEDALE BIELA DE POSICIONAMIENTO PEDAL	PLEUEL PEDALPOSITIONIERUNG BIELA POSICIONADORA PEDAL	2		X		
13	EAM0048G79A	BUSHING, CENTERING- SPRING BOCCOLA CENTRAGGIO MOLLA ЦЕНТРОВОЧНАЯ ВТУЛКА ПРУЖИНЫ	COQUILLE SIEGE RESSORT CASQUILLO CENTRADO MUELLE	BUCHSE ARRUELA CENTRALIZAÇÃO MOLA	1			X	
14	EAM0070G46A	SPACER L=11 mm Distanziale L=11 mm ПРОСТАВКА 11MM	ENTRETOISE L=11 mm DISTANCIADOR L=11 mm	DISTANZSTÜCK L=11 mm DISTANCIADOR L=12 mm	2		X		
15	EAC0096G11A	SPACER-PEDAL Distanziale Pedali РАСПОРКА ПЕДАЛИ СТ.1113/2	ENTRETOISE PÉDALES DISTANCIADOR PEDALES	DISTANZSTÜCK PEDALE DISTANCIADOR PEDAIS	2		X		
16	EAA0356G96A	TURNTABLE/ TILTING VALVE VALVOLA PER TUBI D.4X6 КРАН УПРАВЛЕНИЯ СТОЛОМ / КОЛОННОЙ	SOUPAPE POUR TUBES D.4X6 VÁLVULA PARA TUBOS D.4X6	VALVE FOR 6mm DIA HOSES VÁLVULA PARA TUBOS D.4X6	1		X		X
17	EAK0279G96A	CONTROL PEDALS MOUNTING KIT KIT MONTAGGIO PEDALIERE КОМПЛЕКТ КРЕПЛЕНИЯ ПЕДАЛЕЙ	KIT MONTAGE PEDALIER KIT MONTAJE PEDALERA	MONTAGESSET PEDALEINHEIT KIT MONTAGEM PEDALEIRA	1		X		

A = available - disponible - vorhanden - beschikbaar
= disponibile - disponible - disponível - Доступно

B = on request - sur demande - auf Antrag - op aanvraag
= a richiesta - a petición - no pedido - По запросу

C = suggested - suggeré - vorgeschlagene - aanbevolen
= consigliato - sugerido - sugerido - Предлагается

Pos	Code	Designation Designazione ОПИСАНИЕ	Désignation Designación	Bezeichnung Designação	N.	Note Nota NOTa	A	B	C
18	EAK0279G39A	NUTS/SCREWS FOR FOOT PEDAL ASM KIT VITI PEDALIERA БОЛТЫ И ГАЙКИ ДЛЯ ПЕДАЛИ В СБОРЕ	KIT VIS JEU PÉDALES KIT TORNILLOS JUEGO DE PEDALES	SCHRAUBENSATZ PEDALSTEUERUNG KIT PARAFUSOS PEDALEIRA	1		X		
19	EAS2132G66A	ROD PEDAL POTENTIOMETER BIELLA POTENZIOMETRO ТЯГА ПОТЕНЦИОМЕТР	BIELLE POTENTIOMETRE BIELA POTENCIÓMETRO	POTENTIOMENTERSTANGE BIELA POTENCIOMETRO	2			X	
20	EAK0330G64A	PEDAL CABLE WITH POTENTIOMETER CAVO PEDALIERA CON POTENZIOMETRO ПОТЕНЦИОМЕТР С КАБЕЛЕМ	CABLE PEDALIER AVEC POTENTIOMETRE CABLE PEDALERA CON POTENCIÓMETRO	KABEL PEDALEINHEIT MIT POTENTIOMETER CABO PEDALEIRA COM POTENCIÓMETRO	3		X		
21	EAA0364G11A	HOSES KIT FOR FOOT PEDAL ASM 3P KIT TUBI PEDALIERE 3 PEDALI ШЛАНГИ ДЛЯ КОМПЛ. ПЕДАЛЕЙ 3ШТ.	KIT TUBES PEDALIER 3 PEDALES KIT TUBOS PEDALERA 3 PEDALES	SCHLAUCHSATZ PEDALSTEUERUNG 3 PEDAL KIT TUBOS PEDALEIRAS 3 PEDAIS	1			X	
22	EAS2140G74A	END STROKE FOR PEDAL FINE CORSA PEDALE ОГРАНИЧИТЕЛЯ ХОДА ПЕДАЛЬ	FIN DE COURSE PEDAL FINAL CARRERA PEDAL	ENDSCHALTER PEDAL FIM DE CURSO PEDAL	1			X	
23	EAW0286G08A	CABLE FOR CTS POTENTIOMETER CAVO PER POTENZIOMETRO CTS CTS ПОТЕНЦИОМЕТР КАБЕЛЕМ	CABLE POUR POTENTIOMETRE CTS CABLE POTENCIÓMETRO CTS	KABEL FÜR POTENTIOMETER CTS CABO POTENCIOMETRO CTS	1		X		

A = available - disponible - vorhanden - beschikbaar
= disponibile - disponible - disponível - Доступно

B = on request - sur demande - auf Antrag - op aanvraag
= a richiesta - a petición - no pedido - По запросу

C = suggested - suggeré - vorgeschlagene - aanbevolen
= consigliato - sugerido - sugerido - Предлагается

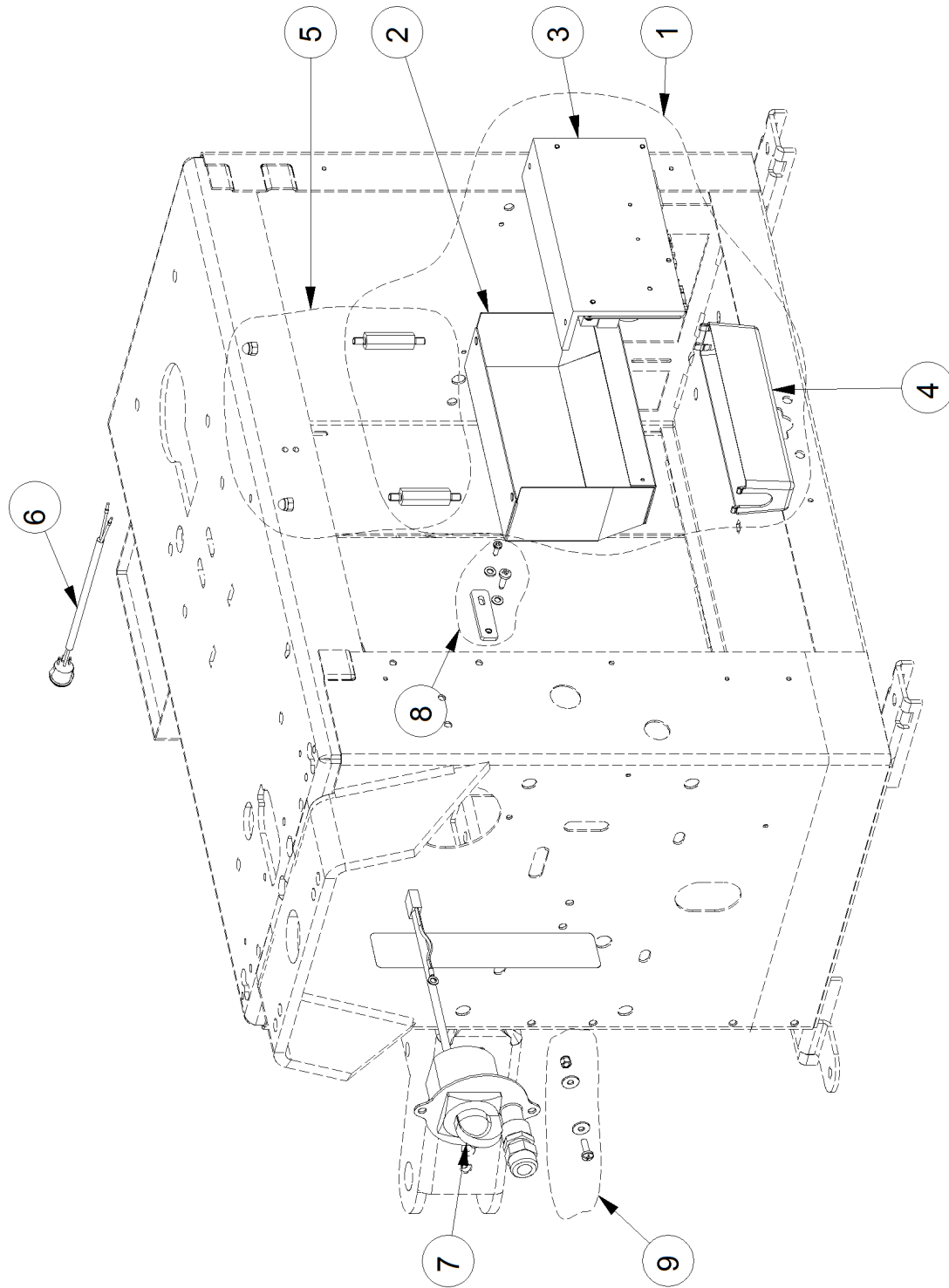

Pos	Code	Designation Designazione ОПИСАНИЕ	Désignation Designación	Bezeichnung Designação	N.	Note Nota HOTa	A	B	C
1	EAA0481G23A	INVERTER GROUP GRUPPO INVERTER x CT ИНВЕРТЕР В СБОРЕ	GROUPE ONDULEUR TC GRUPO INVERTER TC	INVERTEREINHEIT GRUPO INVERTER TC	1	18 rpm-new versior	X		X
2	EAS2139G18A	TC INVERTER COVER COVER PER INVERTER TC КОЖУХ ИНВЕРТЕРА	COUVERCLE POUR ONDULEUR TC TAPA PARA INVERTER TC	ABDECKUNG FÜR INVERTER RM TAMPA PARA INVERTER TC	1		X		
3	EAA0481G15A	INVERTER FOR ENHANCED POTENTIOMETEF INVERTER PER POTENZIOMETRO EVOLUTO ИНВЕРТЕР ДЛЯ ПОВЫШЕНИЯ ПОТ	ONDULEUR POTENTIOMÈTRE ÉVOLUÉ INVERTER POTENCIÓMETRO EVOLUCIONADC	INVERTERFÜR LEISTUNGSSTÄRKEREN POTE INVERTER PARA POTENCIOMETRO EVOLÚIDC	1	18 rpm-new version	X		
4	EAC0103G88A	COVER FOR INVERTER BOX COVER CASSETTA INVERTER КОЖУХ БЛОКА ИНВЕРТЕРА	COUVERCLE BOITE CONVERTISSEUR TAPA CAJA INVERTER	ABDECKUNG INVERTERFACH TAMPA CAIXA INVERTER	1		X		
5	EAK0317G28A	KIT, FIXING FOR INVERTER KIT FISSAGGIO INVERTER КОМПЛЕКТ КРЕПЛЕНИЯ ИНВЕРТЕРА	KIT FIXATION ONDULEUR KIT FIJACIÓN INVERTER	BEFESTIGUNGSSATZ INVERTER KIT FIXAÇÃO INVERTER	1			X	
6	EAK0317G58A	KIT CABLE WITH STOP PUSH BUTTON CSA KIT CAVO PULSANTE DI STOP CSA КАБЕЛЬ С КНОПКОЙ СТОП СЕ	KIT CABLE BOUTON D'ARRET CSA KIT CABLE PULSADOR DE PARO CSA	KIT KABEL STOPPTASTE CSA KIT CABO BOTÃO DE STOP CSA	1		X		
7	EAA0409G00A	ROTARY SWITCH CAM GROUP GRUPPO SEZIONATORE ВЫКЛЮЧАТЕЛЬ ПОВОРОТНЫЙ	GROUPE SECTIONNEUR GRUPO SECCIONADOR	TRENNSCHALTEREINHEIT GRUPO SECCIONADOR	1		X		X
8	EAK0317G29A	KIT, BRACKET FOR INVERTER KIT FISSAGGIO RINVIO PER INVERTER КРЕПЛЕНИЕ КОЖУХА ИНВЕРТЕРА	KIT FIXATION RENVOI POUR ONDULEUR KIT FIJACIÓN TRANSMISIÓN PARA INVERTER	BEFESTIGUNGSSATZ BÜGEL FÜR INVERTER KIT FIXAÇÃO REENVIO PARA INVERTER	1			X	
9	EAK0317G30A	KIT, FIXING FOR SWITCH KIT FISSAGGIO SEZIONATORE КРЕПЛЕНИЕ ВЫКЛЮЧАТЕЛЯ	KIT FIXATION SECTIONNEUR KIT FIJACIÓN SECCIONADOR	BEFESTIGUNGSSATZ TRENNSCHALTER KIT FIXAÇÃO SECCIONADOR	1			X	

A = available - disponible - vorhanden - beschikbaar
= disponibile - disponible - disponivel - Доступно

B = on request - sur demande - auf Antrag - op aanvraag
= a richiesta - a petición - no pedido - По запросу

C = suggested - suggeré - vorgeschlagene - aanbevelen
= consigliato - sugerido - sugerido - Предлагается

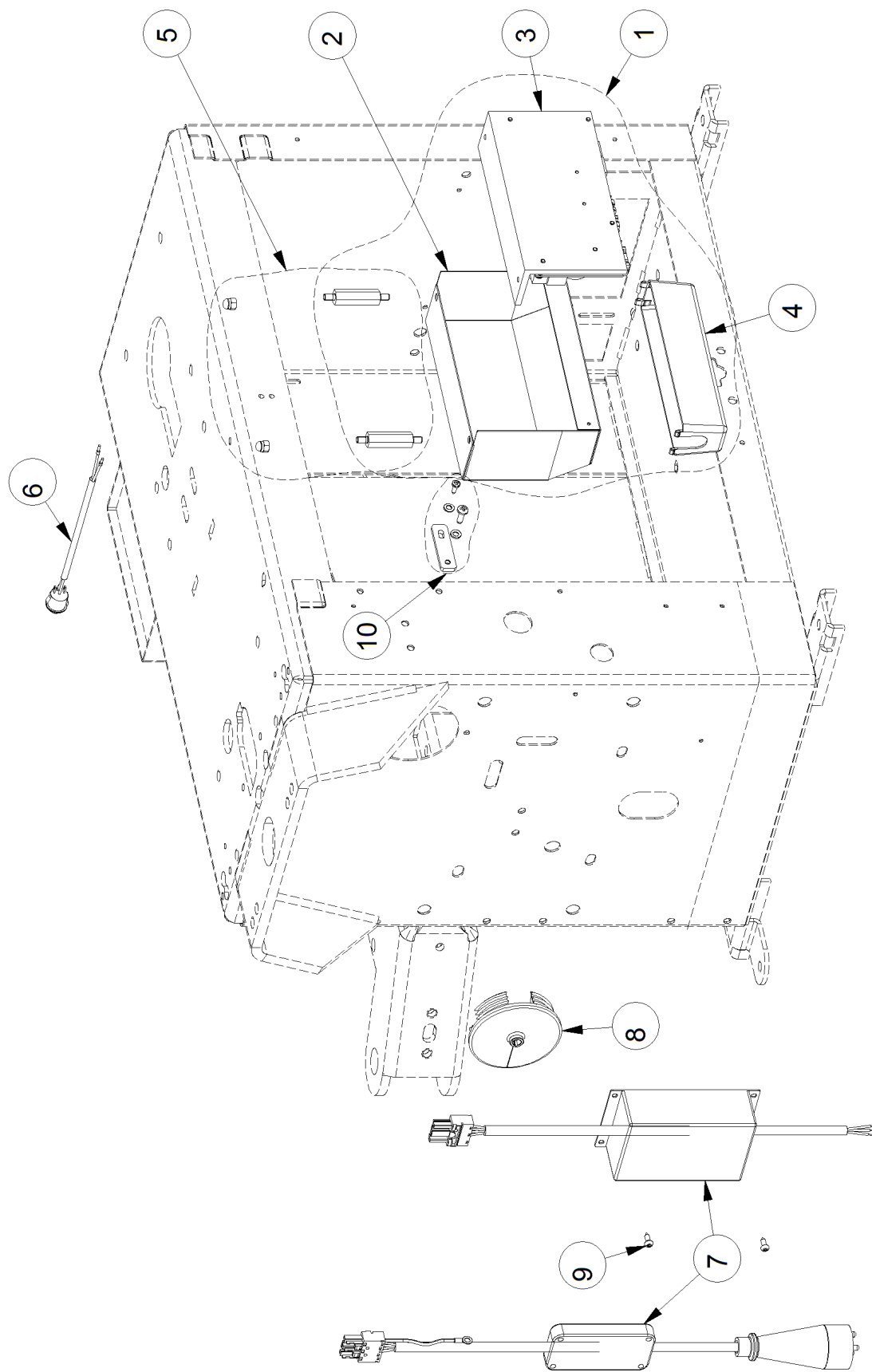

Pos	Code	Designation Designazione ОПИСАНИЕ	Désignation Designación	Bezeichnung Designação	N.	Note Nota HOTa	A	B	C
1	EAA0481G23A	INVERTER GROUP GRUPPO INVERTER x CT ИНВЕРТЕР В СБОРЕ	GROUPE ONDULEUR TC GRUPO INVERTER TC	INVERTEREINHEIT GRUPO INVERTER TC	1	18 rpm-new versior	X		X
2	EAS2139G18A	TC INVERTER COVER COVER PER INVERTER TC КОЖУХ ИНВЕРТЕРА	COUVERCLE POUR ONDULEUR TC TAPA PARA INVERTER TC	ABDECKUNG FÜR INVERTER RM TAMPA PARA INVERTER TC	1		X		
3	EAA0481G15A	INVERTER FOR ENHANCED POTENTIOMETEF INVERTER PER POTENZIOMETRO EVOLUTO ИНВЕРТЕР ДЛЯ ПОВЫШЕНИЯ ПОТ	ONDULEUR POTENTIOMÈTRE ÉVOLUÉ INVERTER POTENCIÓMETRO EVOLUCIONADC	INVERTERFÜR LEISTUNGSSTÄRKEREN POTE INVERTER PARA POTENCIOMETRO EVOLUÍDC	1	18 rpm-new version	X		
4	EAC0103G88A	COVER FOR INVERTER BOX COVER CASSETTA INVERTER КОЖУХ БЛОКА ИНВЕРТЕРА	COUVERCLE BOITE CONVERTISSEUR TAPA CAJA INVERTER	ABDECKUNG INVERTERFACH TAMPA CAIXA INVERTER	1		X		
5	EAK0317G28A	KIT, FIXING FOR INVERTER KIT FISSAGGIO INVERTER КОМПЛЕКТ КРЕПЛЕНИЯ ИНВЕРТЕРА	KIT FIXATION ONDULEUR KIT FIJACIÓN INVERTER	BEFESTIGUNGSSATZ INVERTER KIT FIXAÇÃO INVERTER	1			X	
6	EAK0317G59A	KIT CABLE WITH STOP PUSH BUTTON CE KIT CAVO PULSANTE DI STOP CE КАБЕЛЬ С КНОПКОЙ СТОП	KIT CABLE BOUTON D'ARRET CE CABLE PULSADOR DE PARO CE	KIT KABEL STOPPTASTE CE KIT CABO BOTÃO DE STOP CE	1		X		
7	EAA0393G44A	SUPPRESSOR ASSEMBLY GRUPPO FILTRO ANTIDISTURBO ФИЛЬТР-ПОМЕХОПОДАВИТЕЛЬ	GROUPE FILTRE ANTIPARASITE GRUPO FILTRO ANTIINTERFERENCIAS	ENTSTÖRFILTEREINHEIT GRUPO FILTRO ANTIDISTÚRBIO	1		X		X
7	EAA0438G94A	SUPPRESSOR ASSEMBLY WITH PLUG GRUPPO FILTRO ANTIDISTURBO CON SPINA ФИЛЬТР-ПОМЕХОПОДАВИТЕЛЬ И РАЗЪЕМОМ	GROUPE FILTRE ANTIPARASITE AVEC BROCH GRUPO FILTRO ANTIINTERFERENCIAS CON P	ENTSTÖRFILTEREINHEIT MIT STECKER GRUPO FILTRO ANTIDISTÚRBIO COM TOM.	1	Plug 2P+E 250V 16	X		
7	EAA0472G26A	SUPPRESSOR ASSY.WITH PLUG FOR AUSTR GRUPPO FILTRO ANTIDISTURBO CON SPINA ФИЛЬТР-ПОМЕХОПОДАВИТЕЛЬ И РАЗЪЕМОМ	GROUPE FILTRE ANTIPARASITE AVEC BROCH GRUPO FILTRO ANTIINTERFERENCIAS CON P	ENTSTÖRFILTEREINHEIT MIT STECKER GRUPO FILTRO ANTIDISTÚRBIO COM TOM.	1	AUSTRALIAN PLUG	X		
8	EAC0113G00A	BACK SHEET CABINET COVER COPERCHIO POSTERIORE CABINET ЗАДНИЙ КОЖУХ КОРПУСА	COUVERCLE POSTERIEUR ARMOIRE TAPA POSTERIOR ARMARIO	HINTERE GEHÄUSEABCKUNG TAMPA TORRERIOR ARMÁRIO	1		X		
9	1-20423	SCREW CROWN HEAD, SELF TAP. VITE AUTOF. ВИНТ С КОРОНЧАТОЙ КОЛОВКОЙ	VIS AUTOTAR. TORNILLO AUTORR.	SCHRAUBE, SELBSTSCHNEIDEND PARAFUSO AUTO-ROSC.	2	"D.4,2 13 TCB BR " DIN7981		X	
10	EAK0317G29A	KIT, BRACKET FOR INVERTER KIT FISSAGGIO RINVIO PER INVERTER КРЕПЛЕНИЕ КОЖУХА ИНВЕРТЕРА	KIT FIXATION RENVOI POUR ONDULEUR KIT FIJACIÓN TRANSMISIÓN PARA INVERTER	BEFESTIGUNGSSATZ BÜGEL FÜR INVERTER KIT FIXAÇÃO REENVIO PARA INVERTER	1			X	

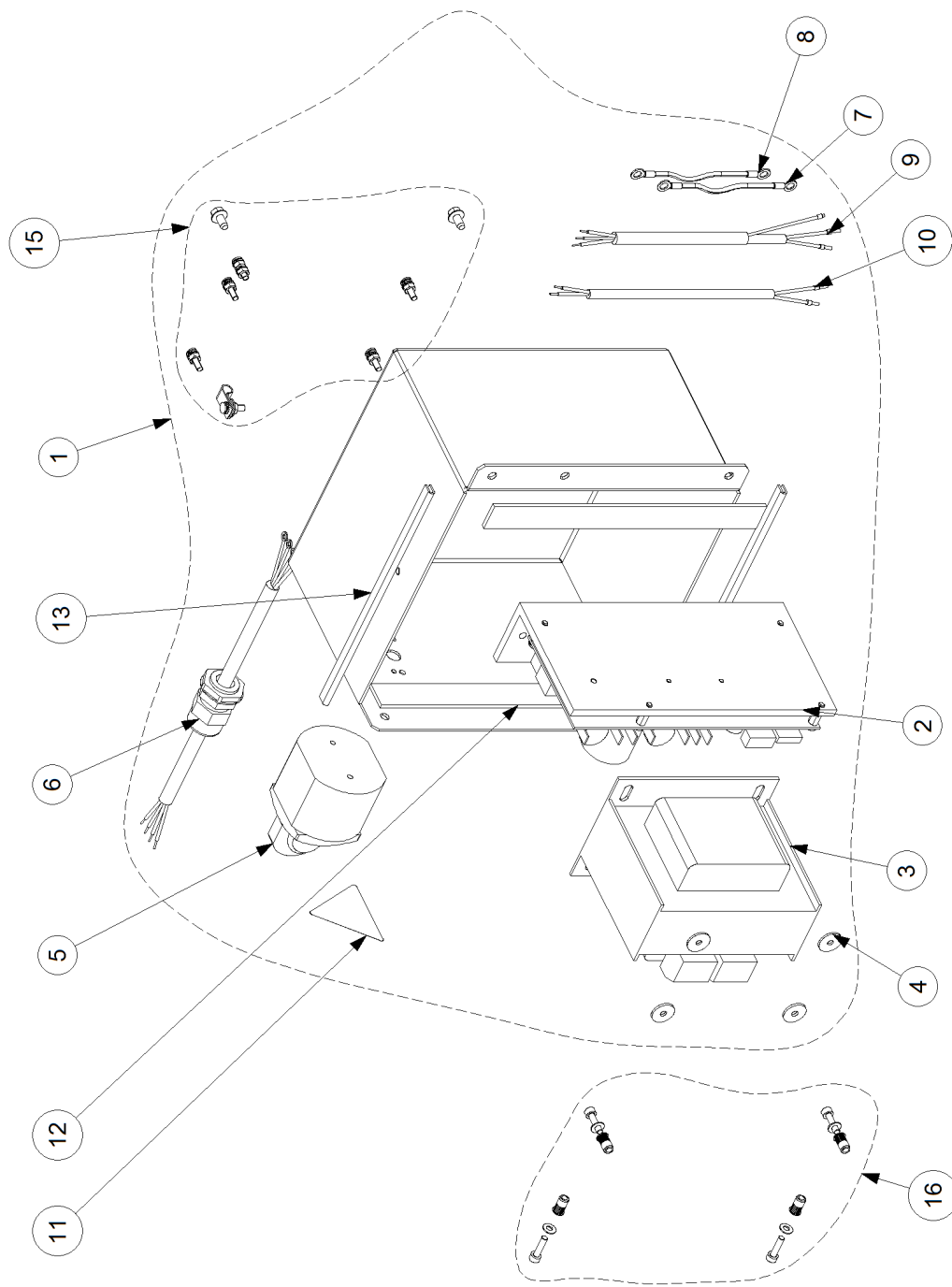

Pos	Code	Designation Designazione ОПИСАНИЕ	Désignation Designación	Bezeichnung Designação	N.	Note Nota HOTa	A	B	C
1	EAA0440G48A	JAPAN INVERTER BOX ASSY ENHANCED POT ENSEMBLE BOITE CONVERTISSEUR JAPAN F ASSIEME CASSETTA INVERTER POTENZIOMETRO E GRUPO CAJA INVERSOR POTENCIÓMETRO E БЛОК ИНВЕРТОРА ПОВЫШЕНИЯ ПОТ. JAPAN		BAUGRUPPE INVERTER-KASTEN LEISTUNGS- CONJUNTO CAIXA INVERTER POTENCIÓMETRO	1	14rpm ENH.POT. JAPAN		X	
1	EAA0457G67A	JPN INVERTER BOX ASSY ENHANCED POTEN ENSEMBLE BOITE CONVERTISSEUR JPN POT ASSIEME CASSETTA INVERTER POTENZIOMETRO E GRUPO CAJA INVERSOR POTENCIÓMETRO E БЛОК ИНВЕРТОРА ПОВЫШЕНИЯ ПОТ. JAPAN		BAUGRUPPE INVERTER-KASTEN LEISTUNGS- CONJUNTO CAIXA INVERTER POTENCIÓMETRO	1	18rpm ENH. POT. JAPAN		X	
2	EAA0440G49A	INVERTER FOR ENHANCED POTENTIOMETEF INVERTER POTENZIOMETRO EVOLUTO ИНВЕРТЕР ДЛЯ ПОВЫШЕНИЯ ПОТ.	VARIATEUR POUR POTENTIOMETRE ÉVOLUÉ INVERTER POTENCIÓMETRO EVOLUCIONADO	INVERTER FÜR LEISTUNGSSTÄRKEREN POTE INVERTER POTENCIÓMETRO EVOLUÍDO	1	14rpm ENH.POT. W/O STOP		X	
2	EAA0457G55A	INVERTER VER.B WITH HEATSINK INVERTER VER.B CON DISSIPATORE ИНВЕРТОР ВЕРСИЯ В С РАДИАТОРОМ	CONVERTISSEUR VER.B AVEC DISSIPATEUR INVERSOR VER. B CON DISIPADOR	INVERTER VER.B MIT WÄRMETAUSCHER INVERTER VER.B COM DISSIPADOR	1	18rpm ENH. POT.		X	
3	7-02602A	AUTOTRANSFORMER 200VAC/230VAC 1400VA/ AUTOTRASFOMATEUR 200VAC/230VAC 140 AUTOTRASFOMATORE 200VAC/230VAC 140i АВТОТРАНСФОРМ. 220В/230В 1400ВА	AUTOTRANSFORMATEUR 200VAC/230VAC 140 AUTOTRANSFORMADOR 200 VCA/230 VCA 140	SPARTRANSFORMATOR 200VAC/230VAC 1400 AUTOTRANSFORMADOR 200VAC/230VAC 1400	1	200VAC/230VAC 14		X	
4	1-22741A	WASHER - d. 4X16X1 BURNISHED RONDELLA COMUNE d.4X16X1 ZINC ШАЙБА - 4x16x1	RONDELLE d. 4X16X1 ARANDELA D.4X16X1 GALVANIZ.	UNTERLEGSCHIEBE D.4X16X1 VERZINKT UNI ARRUELA COMUM d.4X16X1 ZINC	2	D.4X16X1 ZINC UNI 6593 B		X	
5	2-14861A	BIPOLAR POWER SWITCH INTERRUPTTORE BIPOLARE 25A БИПОЛЯРНЫЙ ВЫКЛЮЧАТЕЛЬ ПИТАНИЯ	INTERRUPTEUR BIPOLAIRE 25A INTERRUPTOR BIPOLAR 25A	ZWEIPOLIGER SCHALTER 25A INTERRUPTOR BIPOLAR 25a	2			X	
6	EAW0282G14A	MAINS CABLE CAVO ALIMENTAZIONE КАБЕЛЬ ПИТАНИЯ	CABLE ALIMENTATION CABLE DE ALIMENTACIÓN	KABEL STROMVERSORGUNG CABO ALIMENTAÇÃO	2				X
7	EAW0282G22A	CABINET GROUNDING CABLE CAVO DI TERRA CASSONE КАБЕЛЬ ЗАЗЕМЛЕНИЯ КОРПУСА	CABLE DE TERRE BATI CABLE DE TIERRA CAJA	ERDUNGSKABEL SCHRANK CABO DE TERRA CAIXA	1			X	
8	EAW0282G18A	SUPPRESSOR GROUNDING CABLE CAVO DI TERRA FILTRO ANTIDISTURBO КАБЕЛЬ ЗАЗЕМЛЕНИЯ ПОДАВИТЕЛЯ	CABLE DE TERRE FILTRE ANTIPERTURBATIOI CABLE DE TIERRA FILTRO ANTIPARASITARIO	ERDUNGSKABEL STÖRSCHUTZFILTER CABO DE TERRA FILTRO ANTIDISTÚRBIO	1			X	
9	EAW0282G45A	UTOTRANSFORME-INVERTER CABLE CAVO AUTOTRASFOMATORE-INVERTER КАБЕЛЬ АВТОТРАНСФОРМАТОР-ИНВЕРТОР	CABLE AUTOTRANSFORMATEUR-CONVERTIS CABLE AUTOTRANSFORMADOR-INVERSOR	KABEL SPARTRANSFORMATOR-INVERTER CABO AUTOTRANSFORMADOR-INVERTER	1			X	
10	EAW0282G46A	MAIN SWITCH-AUTOTRANSFORMER CABLE CAVO INTERRUPTTORE-AUTOTRASFOMATOI КАБЕЛЬ ВЫКЛЮЧАТЕЛЬ-АВТОТРАНСФОРМА	CABLE INTERRUPTEUR-AUTOTRASFOMATEI CABLE INTERRUPTOR-AUTOTRANSFORMADO	KABEL TRENNSCHALTER-SPARTRANSFORMA CABO INTERRUPTOR-AUTOTRANSFORMADO	1	200VAC/230VAC 1400VA		X	
11	8-23562A	STICKER, DANGER VDE TARGHETTA PERICOLO VDE НАКЛЕЙКА "ОПАСНО"	PLAQUETTE DANGER VDE TARJETA PELIGRO	GEFAHRENSCHILD VDE PLACA PERIGO VDE	4				X
12	EAM0087G08A	AUTO ADHESIVE SEALING 3x20 GUARNIZIONE GOMMA ESPANSA 3x20 САМОКЛЕЯЮЩАЯСЯ ПРОКЛАДКА 3x20	JOINT CATOUCHOU 3X20 JUNTA GOMA EXPANDIDA 3X20	DICHTUNG SCHAUMGUMMI 3x20 GUARNIÇÃO BORRACHA EXP. 3x20	1				X
13	EAM0087G09A	U PROFILE 2 mm RUBBER GASKET GUARNIZIONE AD "U" IN GOMMA 2 mm РЕЗИНОВАЯ ПРОКЛАДКА U-ПРОФИЛЬ, 2 MM	JOINT CAOUTCHOUC EN "U" 2mm JUNTA EN "U" DE GOMA 2 mm	DICHTUNG, U-FORM, GUMMI 2 mm GUARNIÇÃO EM "U" DE BORRACHA 2 mm	1				X
15	EAK0306G08A	BOLTS AND SCREWS FOR INVERTER BOX KIT VITI CASSETTA INVERTER БОЛТЫ И ВИНТЫ БЛОКА ИНВЕРТОРА	KIT VIS BOITE CONVERTISSEUR KIT TORNILLOS CAJA INVERSOR	SCHRAUBENSATZ INVERTER-KASTEN KIT PARAFUSOS CAIXA INVERTER	1				X
16	EAK0306G07A	KIT FOR INVERTER BOX KIT FISSAGGIO CASSETTA INVERTER КОМПЛЕКТ КРЕПЕЖА ИНВЕРТОРА	KIT FIXATION BOITE CONVERTISSEUR KIT FIJACIÓN CAJA INVERSOR	BEFESTIGUNGSSET INVERTER-KASTEN KIT FIXAÇÃO CAIXA INVERTER	1				X

A = available - disponible - vorhanden - beschikbaar
= disponibile - disponible - disponivel - Доступно

B = on request - sur demande - auf Antrag - op aanvraag
= a richiesta - a petición - no pedido - По запросу

C = suggested - suggeré - vorgeschlagene - aanbevolen
= consigliato - sugerido - sugerido - Предлагается

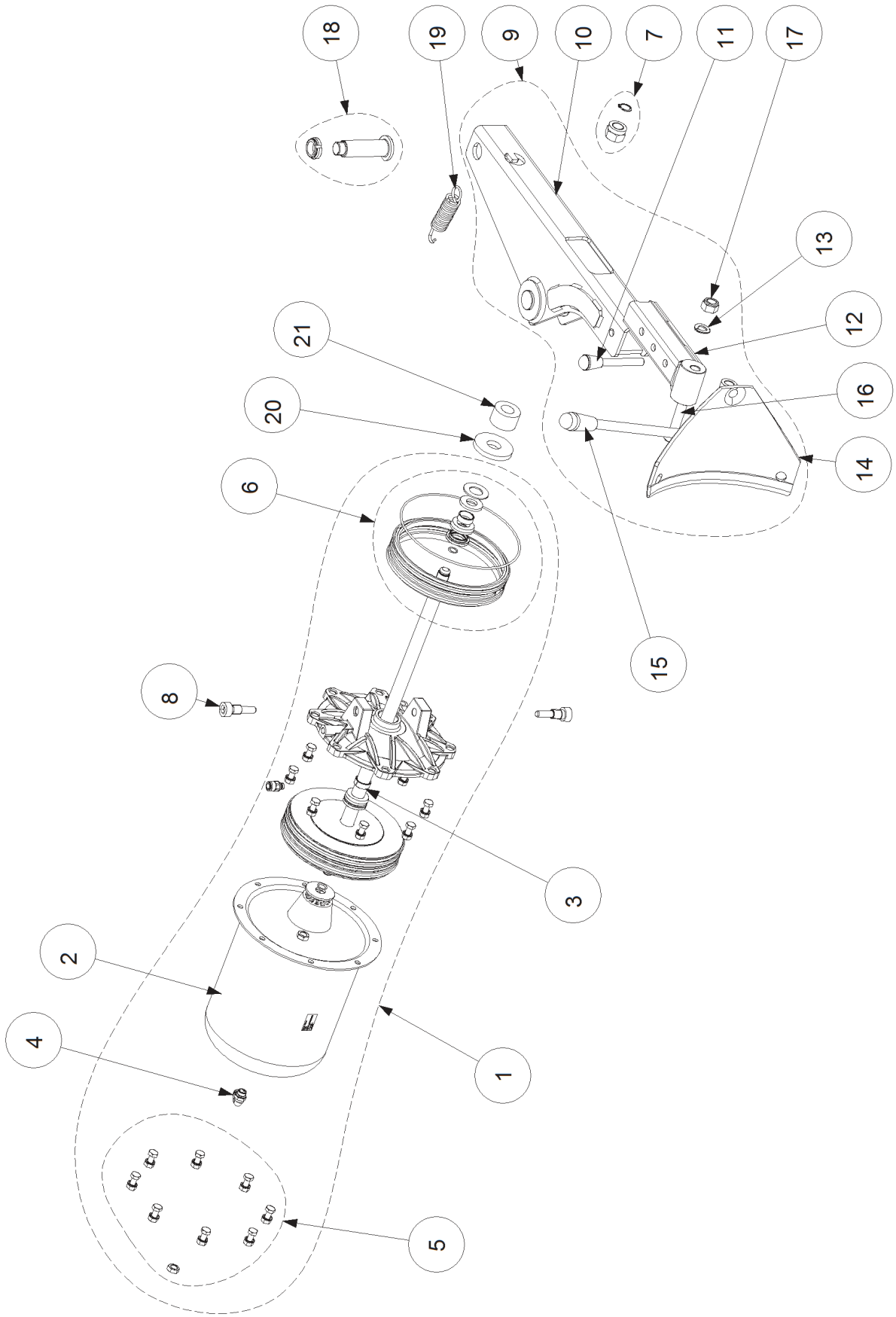

Pos	Code	Designation Designazione ОПИСАНИЕ	Désignation Designación	Bezeichnung Designação	N.	Note Nota HOTa	A	B	C
1	EAA0329G50A	CYLINDER, BEAD BREAKER CILINDRO STALLONATORE ЦИЛИНДР РАЗБОРТИРОВЩИКА	VERIN OUTIL DE DECOR. CILINDRO DESTALLONADOR	ABDRÜCKZYLINDER CILINDRO DESMONT. PNEU	1		X		
2	EAS2068G62A	CYLINDER CHAMBER CAMERA CILINDRO ЦИЛИНДР	CHAMBRE CYLINDRE CAMARA CILINDRO	ZYLINDERKAMMER CÂMARA CILINDRO	1			X	
3	EAM0048G05A	ROD BEAD-BREAKER CYLINDER ASTA CILINDRO STALLONATORE ШТОК ЦИЛИНДРА РАЗБОРТИРОВЩИКА	TIGE CYLINDRE DETALONNEUR VARILLA CILINDRO DESTALONADOR	STANGE ABDRÜCKZYLINDER HASTE CILINDRO DESMONT. PNEU	1		X		
4	1-20179A	FITTING "L" 6X8 RACCORDO RAP. ШТУЦЕР "L" 6X8	RACCORD CONEXION RÁPIDA	L ANSCHLUSS 6X8 ADAPTADOR	1		X		
5	EAK0306G16A	SCREWS AND BOLTS FOR BEAD BREAKER C KIT VITI FLANGIA CIL. STALL. БОЛТЫ КРЕПЛЕНИЯ ЦИЛИНДРА РАЗБОРТ.	KIT VIS FLASQUE VERIN DETAL. KIT TORNILLOS BRIDA CIL. DESTAL.	SCHRAUBENSATZ FLANSCH ABDRÜCKZYLIND KIT PARAFUSOS FLANGE CIL. DESM. PNEU	1		X		
6	EAK0306G19A	SEALS FOR BEAD BREAKER CYL. KIT GUARNIZIONI CIL. STALL. МАНЖЕТЫ ЦИЛИНДРА РАЗБОРТИРОВЩИКА	KIT GARNITURES VERIN DETAL. KIT JUNTAS CIL. DESTAL.	DICHTUNGSSATZ ABDRÜCKZYLINDER KIT GUARN.CIL.DESMT. PNEU	1		X		X
7	EAK0306G23A	FIXING KIT FOR BEAD BREAKER ARM KIT FISSAGGIO BRACCIO STALLONATORE ФИКСАТОР РЫЧАГА РАЗБОРТИРОВЩИКА	KIT FIXATION BRAS DETALONNEUR KIT FIJACIÓN BRAZO DESTALONADOR	BEFESTIGUNGSSATZ ABDRÜCKKARM KIT FIXAÇÃO BRAÇO DESMONT. PNEU	1		X		
8	EAM0067G34A	SCREW, FITTING- CYLINDER B/BREAK VITE FISSAGGIO CILINDRO STAL. БОЛТ ЦИЛИНДРА РАЗБОРТИРОВЩИКА	FIS FIXATION VERIN DETALONNEUR TORNILLO FIJACIÓN CIL.DESTALON.	SCHRAUBE PARAFUSO, JUNÇÃO - CIL.B/DISJUNTOR	2			X	
9	EAA0338G44A	BEAD BREAKER EXTENSIBLE STALLONATORE ESTENSIBILE РЫЧАГ РАЗБОРТИРОВЩИКА	DETTALONEUR EXTENSIBLE DESTALONADORA EXTENSIBLE	ABDRÜCKKARM BRAÇO DESMONT. PNEU	1			X	
10	EAS2108G27A	ARM SUPPORT, BEAD-BREAKER SUPPORTO BRACCIO STALLONATORE ДЕРЖАТЕЛЬ РЫЧАГА	SUPPORT BRAS DETALONNEUR SOPORTE BRAZO DESTALONADORA	HALTERUNG ABDRÜCKKARM SUP. BRAÇO DESM.PNEU PRETO RUGOSO	1		X		
11	EAA0328G72A	PIN - LOCK SPINA POSIZIONATRICE ПАЛЕЦ ФИКСАТОР	GOUPILLE DE REGLAGE ESPIÑA DE REGLAJE	POSITIONIERSTIFT PINO POSICIONADOR	1			X	
12	EAS2087G90A	EXTENSION-ARM, B/BREAKER PROLUNGA BRACCIO STALLONATORE УДЛИНИТЕЛЬ РЫЧАГА РАЗБОРТИРОВЩИКА	RALLONGE BRAS DETALONNEUR EXTENSION-BRAZO DESTALONADOR	VERLÄNGERUNG ABDRÜCKKARM EXTENSAO BRAÇO DESMONT. PNEU	1		X		
13	1-5246	WASHER 14MM RONDELLA ELAS.OND.TIPO B d.14 ШАЙБА 14MM	RONDELLE d.14 ARANDELA ELAST.OND.TIPO B D.14	SCHEIBE 14MM ARRUELA ELAS.OND.TIPO B d.14	1	B d.14 DIN 137	X		
14	EAS2087G93A	BLADE, BEADBREAKER PALETTA STALLONATORE ZINCATO BIANCO ЛЕЗВИЕ РАЗБОРТИРОВЩИКА	PALETTE DETALONNEUR PALETA DESTALONADOR	ABDRÜCKSCHAUFEL WEISS VERZINKT PÁ DESM. DE PNEU ZINCADO BRANCO	1		X		
15	EAC0078G04A	HANDLE-RUBBER POMELLO PER LEVA РУКОЯТКА	POIGNEE POUR LEVIER MANIJA PARA PALANCA	HANDGRIFF PEGADOR PARA ALAVANCA DESMONT.1157/0	1			X	
16	1-22609	SCREW TCEI M14X110 8.8 VITE TCEI M14X110 8.8 BR.UNI5931-67FIL.P ВИНТ TCEI M14X110 8.8	VIS CHC M14X110 8.8 TORNILLO TCEI M14X110 8.8	ZYLINDERSCHRAUBE INNENSECHSK. M14X11 PARAFUSO TCEI M14X110 8.8 BR.UNI5931-67F	1		X		
17	1-10433	NUT-S.LOCK, LOW- M14 DADO M14 AUT.BAS.CL.6 ANE.PLA.BI ГАЙКА САМОКОНТРЯЩАЯСЯ M14	ECROU AUTOBLOCANT M 14 TUERCA M14 AUT.BAS.CL.6	MUTTER, SELBSTSICHERND M14 PORCA M14 AUT.BAIX.CL.6 ANE.PLA.BI	1	M14 aut.bas.cl.6 din 985	X		

A = available - disponible - vorhanden - beschikbaar
= disponibile - disponible - disponivel - Доступно

B = on request - sur demande - auf Antrag - op aanvraag
= a richiesta - a petición - no pedido - По запросу

C = suggested - suggeré - vorgeschlagene - aanbevolen
= consigliato - sugerido - sugerido - Предлагается

Pos	Code	Designation Designazione ОПИСАНИЕ	Désignation Designación	Bezeichnung Designação	N.	Note Nota HOTa	A	B	C
18	EAK0306G20A	FULCRUM KIT FOR BEAD BREAKER ARM KIT FULCRO BRACCIO STALLONATORE КОМПЛЕКТ ЦЕНТРИРУЮЩИХ ФИКСАТОРОВ	KIT PIVOT BRAS DETALONNEUR KIT PERNO BRAZO DESTALONADOR	SATZ DREHPUNKT ABDRÜCKARM KIT FULCRO BRAÇO DESMONT. PNEU	1		X		
19	EAM0067G69A	SPRING-RECALL ARM, BEAD BREAKER MOLLA RITORNO BRACCIO STALL. ПРУЖИНА ВОЗВРАТНАЯ РЫЧАГА	RESSORT RAPPEL BRAS DETALONNEUR MUELLE REGRESO BRAZO DESTAL.	RÜCKHOLFEDER F. ABDRÜCKARM MOLA RETORNO BRAÇO DESM. PNEU	1			X	
20	EAM0067G33A	WASHER,SUPPORT-BEAD BREAKER RONDELLA ARPOG.STALLON.ZINC. BIANCA ШАЙБА КРОНШТЕЙНА РАЗБОРТИРОВЩИКА	RONDELLE APPUI DETALONNEUR ARANDELA SOPORTE DESTALONADOR GALV.	SCHEIBE-ABDRÜCKER ARRUELA, DESM. PNEU SUPORTE	1		X		
21	EAC0097G51A	WASHER - SHOCK ABSORBER RONDELLA AMMORTIZZATRICE ШАЙБА АМОТИЗАТОРА	RONDELLE- AMORTISSEMENT ARANDELA DE AMORTIGUACIÓN	SCHEIBE ARRUELA AMORTECEDORA	1		X		

A = available - disponible - vorhanden - beschikbaar
= disponibile - disponible - disponível - Доступно

B = on request - sur demande - auf Antrag - op aanvraag
= a richiesta - a petición - no pedido - По запросу

C = suggested - suggeré - vorgeschlagene - aanbevolen
= consigliato - sugerido - sugerido - Предлагается

EAZ0090G16A

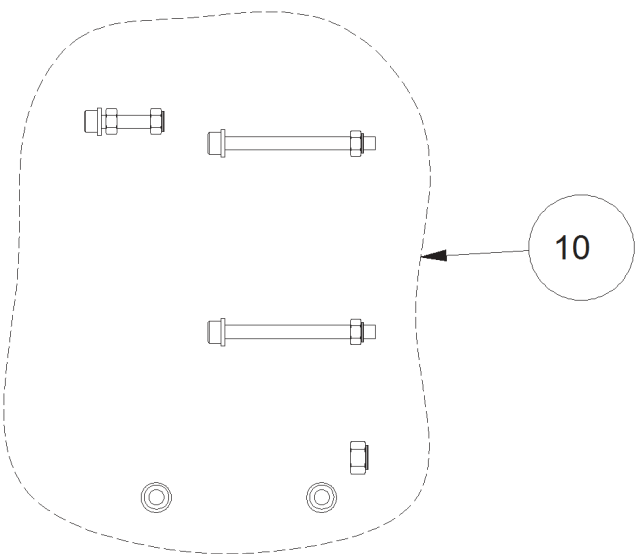
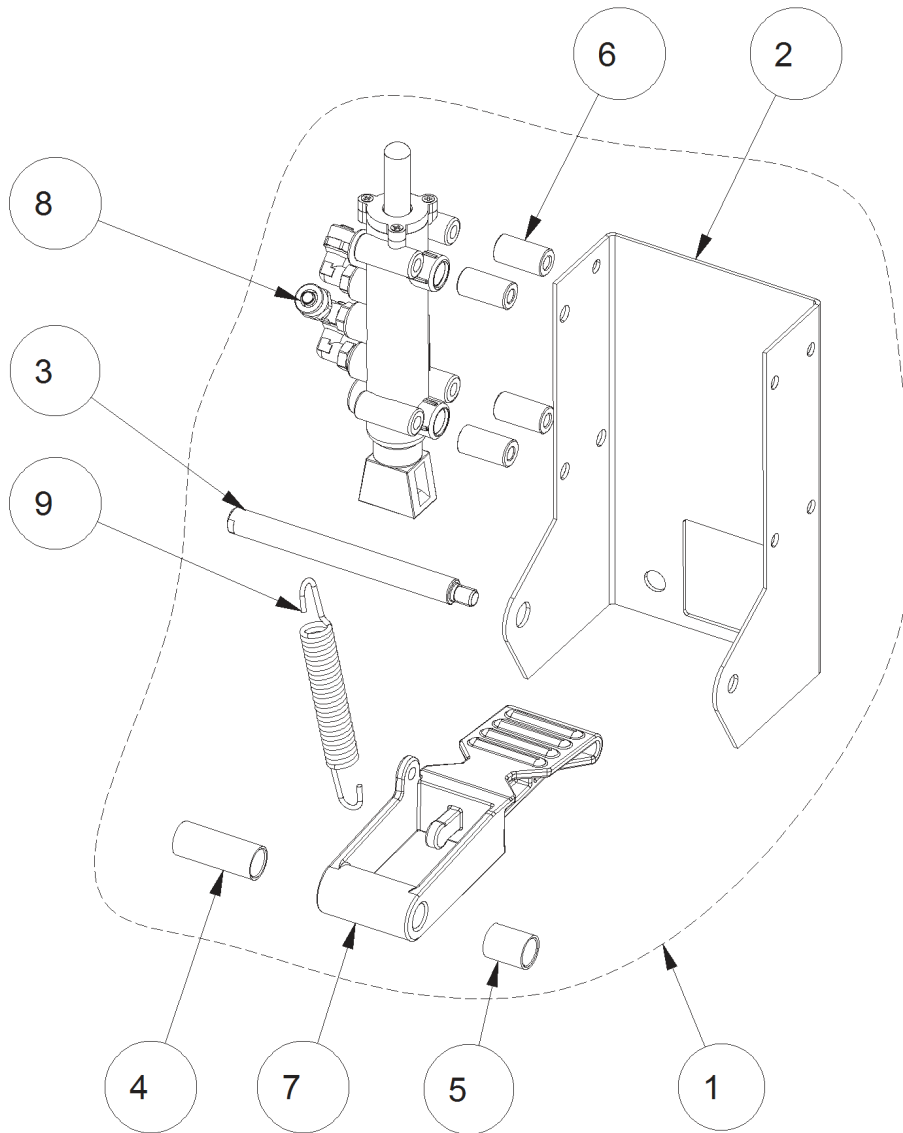

05/2015

Pos	Code	Designation Designazione ОПИСАНИЕ	Désignation Designación	Bezeichnung Designação	N.	Note NOTa	Nota	A	B	C
1	EAA0362G31A	BEAD BREAKER FOOT PEDAL ASM GRUPPO PEDALE STALLONATORE ПЕДАЛЬ РАЗБОРТИРОВЩИКА	PEDALIER DETALONNEUR GRUPO PEDAL DESTALONADOR	ABDRÜCKPEDALSTEUERUNG PEDAL DESMONT. PNEU	1				X	
2	EAS2115G46A	BEAD BREAKER PEDAL SUPPORT SHEET LAMIERA SUPPORTO PED. STALLONATORE КРОНШТЕЙН ПЕДАЛИ РАЗБОРТИРОВЩИКА	SUPPORT PEDAL. DETALONNEUR ACIER CHAPA DE SOPORTE PEDAL	TRAGBLECH ABDRÜCKPEDAL CHAPA SUPORTE PED. DESMONT. PNEU	1				X	
3	EAM0075G89A	BEAD BREAKER PEDAL SHAFT PERNO FULCRO PEDALE STALLONATORE ОСЬ ПЕДАЛИ РАЗБОРТИРОВЩИКА	AXE PIVOT PEDALE DETALONNEUR PERNO PIVOTE PEDAL DESTALONADOR	DREHPUNKTBOLZEN ABDRÜCKPEDAL PINO FULCRO PEDAL DESMONT. PNEU	1			X		
4	EAM0075G90A	FOOT PEDAL SPACER DISTANZIALE PEDALIERA ПРОСТАВКА ПЕДАЛИ	PIÈCE D'ÉCARTEMENT PEDAL DISTANCIADOR JUEGO DE PEDALES	DISTANZSTÜCK PEDALSTEUERUNG DISTANCIADOR PEDALEIRA	1			X		
5	EAM0074G76A	Ø13x21 SPACER DISTANZIALE Ø13 L=21 ПРОСТАВКА Ø13X21	PIÈCE D'ÉCARTEMENT DISTANCIADOR	DISTANZSTÜCK DISTANCIADOR Ø13 L=21	1				X	
6	EAM0074G79A	SPACER Ø6,2 L=25 DISTANZIALE Ø6,2 L=25 ПРОСТАВКА 6,2X25	PIÈCE D'ÉCARTEMENT DISTANCIADOR	DISTANZSTÜCK DISTANCIADOR Ø6,2 L=25	4				X	
7	EAM0068G96A	BEAD BREAKER PEDAL - MACHINED PEDALE STALLONATORE - LAVORATO ПЕДАЛЬ РАЗБОРТИРОВЩИКА	PEDALE DETALONNEUR PEDAL DESTALONADOR - MECANIZADO	ABDRÜCKPEDAL, BEARBEITET PEDAL DESMONT. PNEU - TRABALHADO	1				X	
8	EAA0356G94A	VALVE BEAD-BREAKER VALVOLA STALLONATORE КЛАПАН РАЗБОРТОВОЧНОГО УСТРОЙСТВА	VALVE DÉTALONNEUR VÁLVULA DESTALONADOR	ABDRÜCKERVENTIL VÁLVULA DESMONT. PNEU	1			X		X
9	EAM0074G78A	SPRING WIRE Ø2,2 L=115 mm MOLLA FILO Ø2,2 L=115 mm ПРУЖИНА	RESSORT FIL Ø2,2 L=115 mm MUELLA HILO Ø2,2 L=115 mm	DRAHTFEDER Ø2,2 L=115 mm MOLRENTE Ø2,2 L=115 mm	1				X	
10	EAK0279G43A	NUTS/BOLTS FOR BEAD BREAKER PED. KIT VITI PEDALE STALLONATORE БОЛТЫ И ГАЙКИ ПЕДАЛИ РАЗБОРТИРОВЩИКА	KIT VIS PEDALE DETALONNEUR KIT TORNILLOS PEDAL DESTALONADOR	SCHRAUBENSATZ ABDRÜCKER KIT PARAFUSOS PEDAL DESMONT. PNEU	1			X		

A = available - disponible - vorhanden - beschikbaar
= disponibile - disponible - disponivel - Доступно

B = on request - sur demande - auf Antrag - op aanvraag
= a richiesta - a petición - no pedido - По запросу

C = suggested - suggeré - vorgeschlagene - aanbevelen
= consigliato - sugerido - sugerido - Предлагается

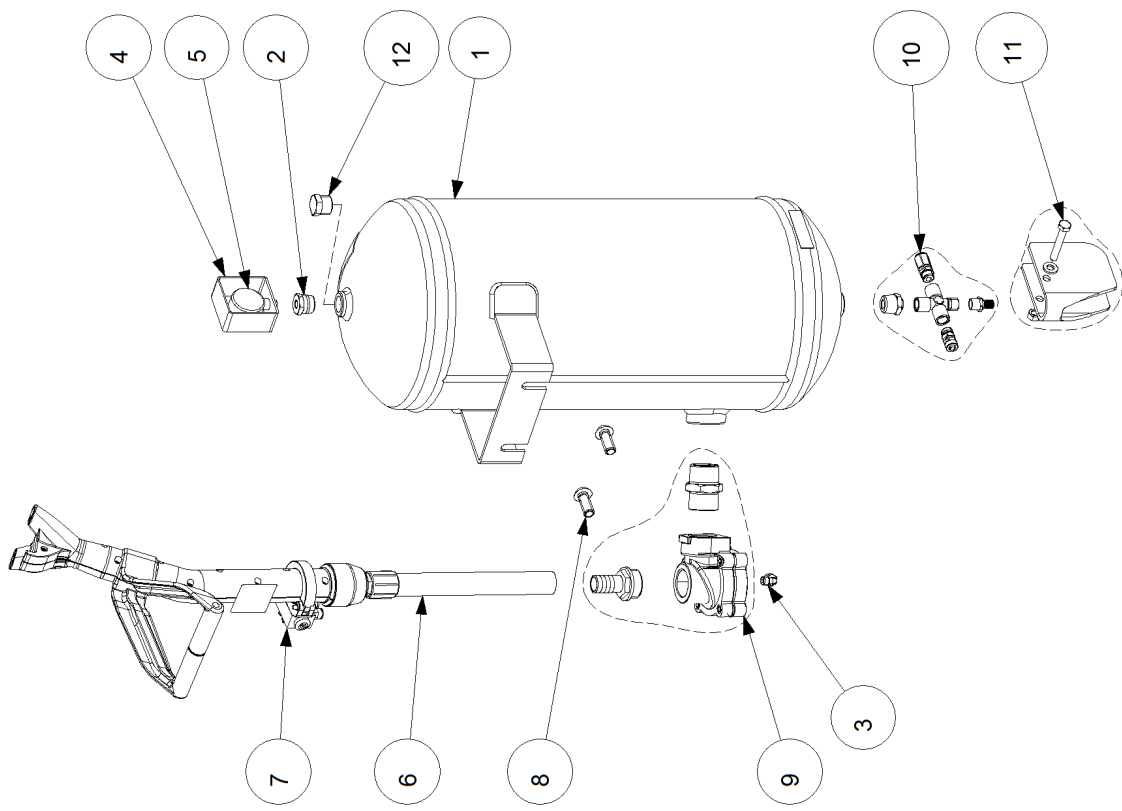

Pos	Code	Designation Designazione ОПИСАНИЕ	Désignation Designación	Bezeichnung Designação	N.	Note Nota HOTa	A	B	C
1	EAS2089G67A	TANK - INFLATOR SERBATOIO GONFIATUBELESS VERNICIATO РЕСИБЕР	RESERVOIR POMPE LAQUE NOIR TANQUE INFLATOR TUBELESS	BEHÄLTER F. SCHLAUCHLOSREIFENPUMPE, I TANQUE INFLATUBELESS ENVERNIZADO PRE	1		X		
2	1-12579A	STRAIGHT, FITTING MF 1/2"-1/8" RIDUZIONE MF 1/2"-1/8" CILINDRICO ШТУЦЕР ПРЯМОЙ 1/2" - 1/8"	REDUCTION MF 1/2"-1/8" CYLINDRIQUE REDUCCIÓN MH 1/2"-1/8" CILÍNDRICO	MF-ADAPTER 1/2"-1/8", ZYLINDRISCH REDUÇÃO MF 1/2"-1/8" CILÍNDRICO	1	"3/8""-1/8"" CIL"	X		
3	1-17179A	ELBOW FITTING "L" 4X6 1/4" RACCORDO A VITE A "L" 4X6 1/4" "L" ШТУЦЕР СТАКАНА 4X6 1/4"	ELBOW FITTING "L" 4X6 1/4" CONEXIÓN DE TORNILLO EN "L" 4X6 1/4"	L-FÖRMIGER-ANSCHLUSS M. GEWINDE 4X6 JUNÇÃO AO PARAFUSO A "L" 4X6 1/4"	1		X		
4	EAM0074G01A	PROTECTION, MANOMETER PROTEZIONE MANOMETRO NERO BUCCIATO ЗАЩИТА МАНОМЕТРА	PROTECTION MANOMETRE PROTECCIÓN MANÓMETRO	ABDECKUNG F. MANOMETER, SCHWARZ HAN PROTEÇÃO MANÓMETRO PRETO RUGOSO	1			X	
5	8-06120A	MANOMETER-RADIAL 0-16 D.40 MANOMETRO RADIALE 0-16 D.40 МАНОМЕТР 0-16 D 40	MANOMETRE RADIAL 0-16 D.40 MANÓMETRO RADIAL 0-16 BAR D.40	MANOMETER, RADIAL 0-16 D.40 MANÓMETRO RADIAL 0-16 D.40	1		X		
6	EAA0363G53A	GT ASSEMBLY GRUPPO GT ВЗРЫВНАЯ НАКАЧКА В СБОРЕ	GROUPE GT GRUPO GT	GT-BAUGRUPPE CONJUNTO GT	1		X		
7	EAA0362G84A	BEAD INFLATOR CONTROL VALVE VALVOLA AZIONAMENTO GT COMPLETA КЛАПАН УПРАВЛЕНИЯ НАКАЧКОЙ	VALVE ACTIONNEMENT DETALONNEUR VÁLVULA ACCIONAMENTO GT COMPLETA	VENTIL, GT-AKTIVIERUNG, KOMPLETT VÁLVULA ACIONAMENTO GT COMPLETA	1			X	
8	1-58409A	SCREW VITE ВИНТ	VIS TORNILLO	SCHRAUBE PARAFUSO	1	M12X30 8K ISO 7380	X		
9	EAK0306G44A	ASSY, VALVE FOR GT NOZZLE KIT VALVOLA PER UGELLO GT КЛАПАН В СБОРЕ СОПЛА ВЗРЫВНОЙ НАКАЧ	KIT SOUPE POUR BUSE GT KIT VÁLVULA PARA BOQUILLA GT	SET VENTIL FÜR GT-DÜSE KIT VÁLVULA PARA BICO DE SOPRO GT	1		X		X
10	EAK0306G46A	FITTINGS FOR GT NOZZLE KIT RACCORDI UGELLO GT ШТУЦЕРЫ ДЛЯ СОПЕЛ GT	KIT RACCORDS BUSE GT KIT CONEXIONES BOQUILLA GT	SET ANSCHLÜSSE GT-DÜSE KIT JUNÇÕES BICO DE SOPRO GT	2			X	
11	EAK0306G45A	FITTINGS PROTECTION FOR GT KIT PROTEZIONE RACCORDI GT ЗАЩИТА ШТУЦЕРОВ GT	KIT PROTECTION RACCORDS GT KIT PROTECCIÓN RACORES GT	SCHUTZ-SET GT-ANSCHLÜSSE KIT PROTEÇÃO JUNÇÕES GT	1			X	
12	1-09276A	1/2" CAP TAPPO 1/2" ЗАГЛУШКА 1/2"	BOUCHON 1/2" TAPÓN 1/2"	VERSCHLUSS 1/2" TAMPA 1/2"	1			X	

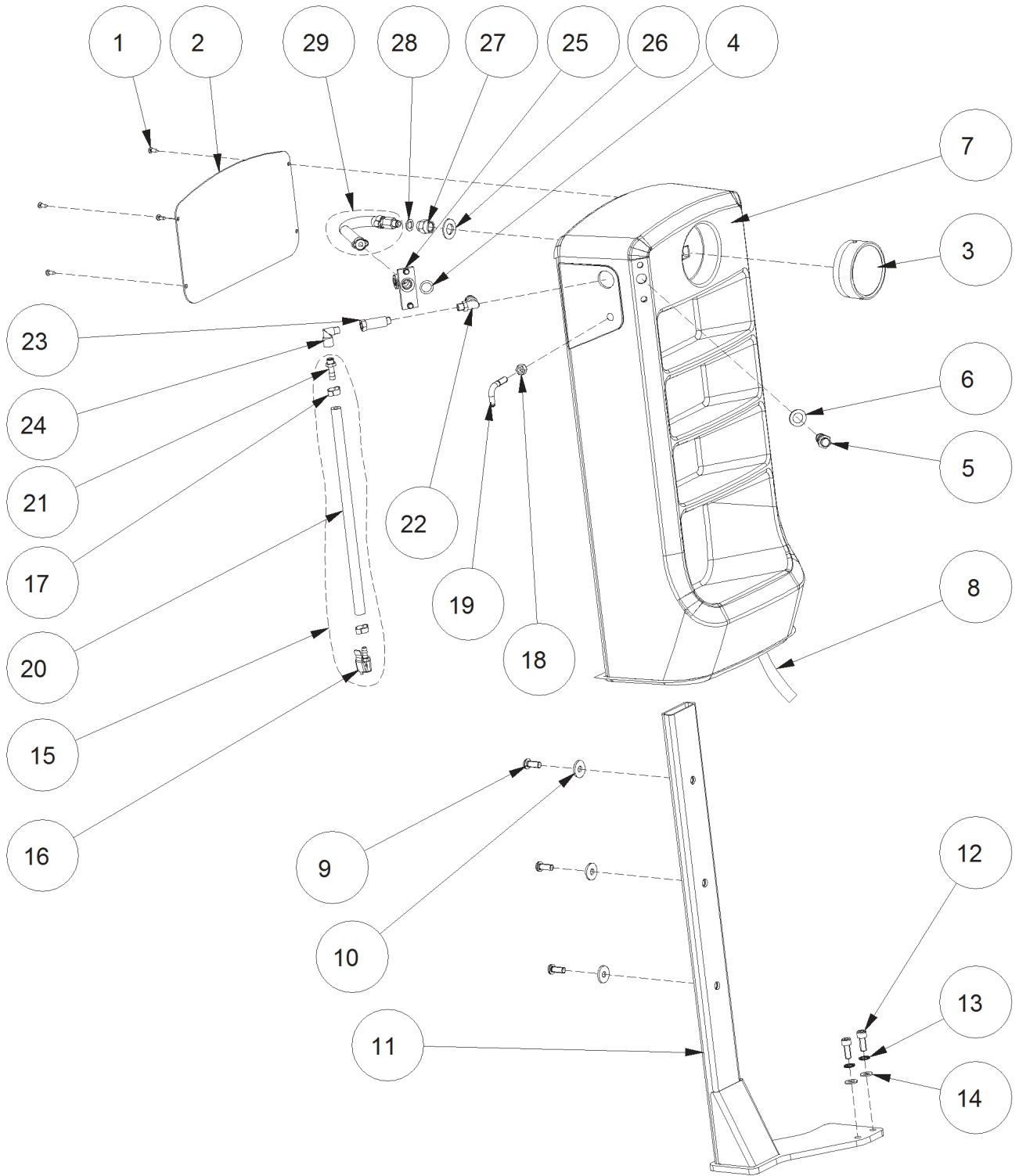

Pos	Code	Designation Designazione ОПИСАНИЕ	Désignation Designación	Bezeichnung Designação	N.	Note Nota HOTa	A	B	C
1	1-20423	SCREW CROWN HEAD, SELF TAP. VITE AUTOF. ВИНТ С КОРОНЧАТОЙ КОЛОВКОЙ	VIS AUTOTAR. TORNILLO AUTORR.	SCHRAUBE, SELBSTSCHNEIDEND PARAFUSO AUTO-ROSC.	4	"D.4,2 13 TCB BR " DIN7981		X	
2	EAS2153G75A	COVER, FOR BOX, BLACK PAINTED LAMIERA CHIUSURA CASSETTA NERO BUCC. КОЖУХ БЛОКА, ЧЕРНЫЙ	COUVERCLE BOITE NOIRE TAPA POR CAJA NEGRA	COVER, FOR BOX, BLACK PAINTED TAMPA PARA CAIXA, PRETA	1			X	
3	8-06520A	MANOMETER EEC APPROVED 0-10 BAR MANOMETRO CEE МАНОМЕТР ЕЕС 0-10 БАР	MANOMETRE CEE MANÓMETRO NORMAS CEE	MANOMETER, EG-GEPRÜFT D.80 1/4 0-10 BAR MANÓMETRO EEC	1	BAR		X	
3	EAC0078G28A	MANOMETER D80 EEC BAR/PSI MANOMETRO D80 CEE 10 BAR/PSI * МАНОМЕТР 080 ЕЕС БАР/ПСИ	MANOMETRE D80 CEE BAR/PSI MANÓMETRO D80 CEE BAR/PSI	MANOMETER D80 EWG 10 BAR/PSI * MANÓMETRO D80 CEE 10 BAR/PSI *	1			X	
3	EAA0332G41A	GAUGE-AIR PSI / Кра MANOMETRO PSI / Кра МАНОМЕТР PSI/кПа	MANOMETRE PSI/Кра MANÓMETRO PSI/Кра	MANOMETER PSI/Кра MANÓMETRO PSI / Кра	1			X	
4	8-10414A	SEAL-OR d.14 GUARNIZIONE OR d.14 OR 3056 МАНЖЕТА D 14	JOINT OR d. 14 JUNTA OR d.14	DICHTUNG OR D.14 OR 3056 VEDAÇÃO-OR d.14	1			X	
5	EAA0328G57A	BLEEDER VALVE VALVOLA SGONFIATORE КЛАПАН СБРОСА ДАВЛЕНИЯ	VALVE DEGONFLAGE VALVULA DESENFADOR	VENTIL LUFTABLASSVORR. VÁLVULA DESINSUFLADOR	1			X	
6	EAM0043G64A	WASHER, BLEEDER VALVE RONDELLA PER BLOCCHETTO SGONFIATORI ШАЙБА КЛАПАНА	RONDELLE SOUPAPE DEGONFLAGE ARANDELA PARA BLOQUE DESHINCHADOR	SCHEIBE FÜR LUFTABLASSVENTIL ARRUELA PARA BLOCO DESINFLADOR	1			X	
7	EAC0114G08A	TOOL STORAGE BOX CASSETTA PORTA OGGETTI КОРОБ ДЛЯ ХРАНЕНИЯ ИНСТРУМЕНТА	CASSETTE PORTE-OBJECTS CAJON PUERTA OBJETOS	OBJEKTkasten CAIXA DE FERRAMENTAS	1			X	
8	24201	HOSE-AIR 6X8, BLACK TUBO ARIA 6X8 NERO L.1600 ПНЕВМОШЛАНГ 6X8	TUYAU AIR 6X8, NOIR TUBO AIRE 6X8, NEGRO	PNEUMATIKLEITUNG 6X8 SCHWARZ TUBO DE AR 6X8 PRETO L.1600	1			X	
9	1-18702A	SCREW FILLISTER HEAD MACH M8X20 ISO VITE TBEI ВИНТ С ЦИЛИНДРИЧЕСКОЙ ГОЛОВКОЙ	VIS BHc TORNILLO TBEI	SCHRAUBE 8X20 10.9 BR. ISO7380 PARAFUSO TBEI	3	8X20 ISO7380 (B)		X	
10	1-17841A	WASHER d. 8X24, BLK RONDELLA COMUNE d.8x24 BR. ШАЙБА 8X24	RONDELLE D 8X 24 ARANDELA D 8X 24	UNTERLEGSCHIEBE D 8X 24 UNI6593 ARRUELA COMUM d.8x24 BR.	3	D.8x24		X	
11	EAA0410G29A	SUPPORT FOR STORAGE BOX SUPPORTO CASSETTA PORTAOGG. + RIVETI КРОНШТЕЙН КОРОБА	SUPPORT CASSETTE PORTE-OBJETS SOPORTE CAJA PORTAOBJETOS + REMACHE	HALTERUNG ABLAGEFACH + NIETEN SUORTE PARA CAIXA DE FERRAMENTAS	1			X	
12	1-17709	SCREW TCEI 8X20 8G VITE TCEI ВИНТ TCEI M8X20	VIS CHc TORNILLO TCEI	ZYLINDERSCHRUB.M.ISKT.M8X20-8.8-A2J PARAFUSO TCEI	2	M8X100 8K ISO 4762		X	
13	1-3048	WASHER SHAKEPROOF D8 BLK. RONDELLA DE d.8 BRUNITA. ШАЙБА D8	RONDELLE DIAM 8 ARANDELA DE D.8	SCHEIBE D.8 ARRUELA DE D.8 BRUNIDA	2	D.8 DIN 6798/A		X	
14	1-10041	WASHER D.8 RONDELLA P.D.8 Z.BIANCA ШАЙБА D 8	RONDELLE DIAM 8 ARANDELA PLANA D.8 GALVANIZ.	SCHEIBE B 8,4 -A2J ARRUELA P.D.8 Z.BRANCA	2	D8-UNI6592-69 DIN 125		X	
15	EAA0329G99A	HOSE, INFLAT.GUN WITH FITTINGS TUBO PISTOLA CON RACCORDI ШЛАНГ ПИСТОЛЕТА ДЛЯ НАКАЧКИ	TUYAU PISTOLET AVEC RACCORDS TUBO PISTOLETA INFLAJE + EMPALM	SCHLAUCH F. FÜLLPISTOLE MIT ANSCHLÜSSI TUBO PISTOLA COM JUNÇÕES	1			X	

A = available - disponible - vorhanden - beschikbaar
= disponibile - disponible - disponivel - Доступно

B = on request - sur demande - auf Antrag - op aanvraag
= a richiesta - a petición - no pedido - По запросу

C = suggested - suggeré - vorgeschlagene - aanbevolen
= consigliato - sugerido - sugerido - Предлагается

Pos	Code	Designation Designazione ОПИСАНИЕ	Désignation Designación	Bezeichnung Designação	N.	Note Nota HOTa	A	B	C
16	1-12279A	INFLATING CHUCK PINZA DI GONFIAGGIO * НАКОНЕЧНИК ШЛАНГА	PINCE GONFLAGE PINZA DE HINCHADO	FÜLLVENTIL, SPANNFUTTER PINÇA DE INSUFLAMENTO	1		X		
17	1-03482A	HOSE CLAMP FASCETTA STRINGITUBO 13-15 *PINZABILI ХОМУТ ШЛАНГА	COLLIER SERRE-TUBE ABRAZADERA APRIETA-TUBO 13-15 MM *CON	3SCHLAUCHKLEMMEN 13-15 GRAMPO TUBO	2	13-15 MM	X		
18	1-11733	NUT M8 UNI5588-65/DIN934 DADO M8 CL.8 NORM.ZINC.BIANCO ГАЙКА М8	ECROU M8 6S STAND.JAUNE TUERCA M8 6S NORM.GALV.BLANCA	SECHSKANTMUTTER M 8 -8-A2J PORCA M8 CL.8 NORM.ZINC.BRANCO	1	M8 8K DIN 934	X		
19	EAM0032G94A	HOOK FOR INFLATING GAUGE GANCIO ATTACCO PISTOLA КРЮК	CROCHET PISTOLET DE GONFLAGE GANCHO PISTOLA HINCHADO	HAKEN, FÜLLMANNOMETER GANCHO CONEXAO PISTOLA	1			X	
20	EAN0049G13A	TIRE GUN TUBE TUBO ARIA PISTOLA ШЛАНГ ПИСТОЛЕТА НАКАЧКИ	TUYAU AIR PISTOLET TUBO AIRE PISTOLA	LUFTSCHLAUCH TUBO INJETOR PNEU	1		X		
21	1-12079A	FITTING - AIR 1/8 d.7 RACCORDO ARIA 1/8 D.7 ШТУЦЕР 1/8 D7	RACCORD AIR 1/8 d.7 CONEXIÓN 1/8 d.7	LUFT-VERSCHRAUBUNG 1/8 D.6 JUNÇÃO AR 1/8 D.7	1	D7	X		
22	1-11479A	FITTING - L 6X8 1/8 RACCORDO RAP.GIR. A L 6X8 1/8 * ШТУЦЕР L 6X8 1/8"	RACCORD EN L 6X8 1/8 CONEXIÓN EN L 6X8 1/8	VERSCHRAUBUNG 6X8 1/8 JUNÇÃO - L 6X8 1/8	1		X		
23	1-11779A	FITTING, STRAIGHT, M/F 1/4" L.36mm RACCORDO DRITTO M/F 1/8" L.36mm ШТУЦЕР ПРЯМОЙ 1/4" L=36MM	RACCORD DROIT M/F 1/4" L36MM CONEXIÓN DERECHO M/F 1/4" L.36MM	GERADER ANSCHLUSS M/W 1/8" L=36 mm JUNÇÃO RETA M/F 1/8" L.36mm	1			X	
24	1-11979A	FITTING L MF 1/8" RACCORDO ШТУЦЕР 1/8"-4	RACCORD CONEXIÓN	L-VERSCHRAUBUNG MF 1/8" JUNÇÃO	1		X		
25	EAC0078G59A	BODY BLEEDER VALVE BLOCCETTO SGONFIATORE КРОНШТЕЙН КРЕПЛЕНИЯ ТРОЙНИКА	VALVE-DEGONFLEUR BLOQUE DESHINCHADOR	BLOCK FÜR LUFTABLASSVORR. CORPO, VÁLVULA DE PURGA	1		X		
26	1-10341	WASHER - d.14 RONDELLA PIANA D.14 ZINC ШАЙБА D 14	RONDELLE d.14 ARANDELA PLANA D.14 GALVANIZ.	SCHEIBE D.14 ARRUELA D14	1	D.14 white zinc UNI 6592-70	X		
27	1-11879A	COUPLING REDUCT. FF 1/4-1/8" MANICOTTO RIDOTTO FF 1/4-1/8" АДАПТЕР 1/4"-1/8"	MANCHON REDUCT. FF 1/4-1/8" CASQUILLO REDUCT. FF 1/4-1/8"	REDUZIERKUPPLUNG FF 1/4-1/8" PAR REDUTOR FF 1/4-1/8"	1		X		
28	1-26741A	WASHER, COPPER 1/8 RONDELLA RAME 1/8 ШАЙБА МЕДНАЯ 1/8	RONDELLE EN CUIVRE 1/8 ARANDELA EN COBRE 1/8	UNTERLEGSCHIEBE KUPFER 1/8 ARRUELA COBRE 1/8	1		X		
29	EAA0356G06A	PIPE, W. MANOMETER DAMPER TUBO CON SMORZATORE MANOMETRO ШЛАНГ МАНОМЕТРА	TUYAU AMORTISSEUR MANOMETRE TUBO C.AMORTIGUADOR MANÓMETRO	ROHR MIT DÄMPFER F. MANOMETER TUBO COM REDUTOR MANÓMETRO	1			X	

A = available - disponible - vorhanden - beschikbaar
= disponibile - disponible - disponivel - Доступно

B = on request - sur demande - auf Antrag - op aanvraag
= a richiesta - a petición - no pedido - По запросу

C = suggested - suggeré - vorgeschlagene - aanbevolen
= consigliato - sugerido - sugerido - Предлагается

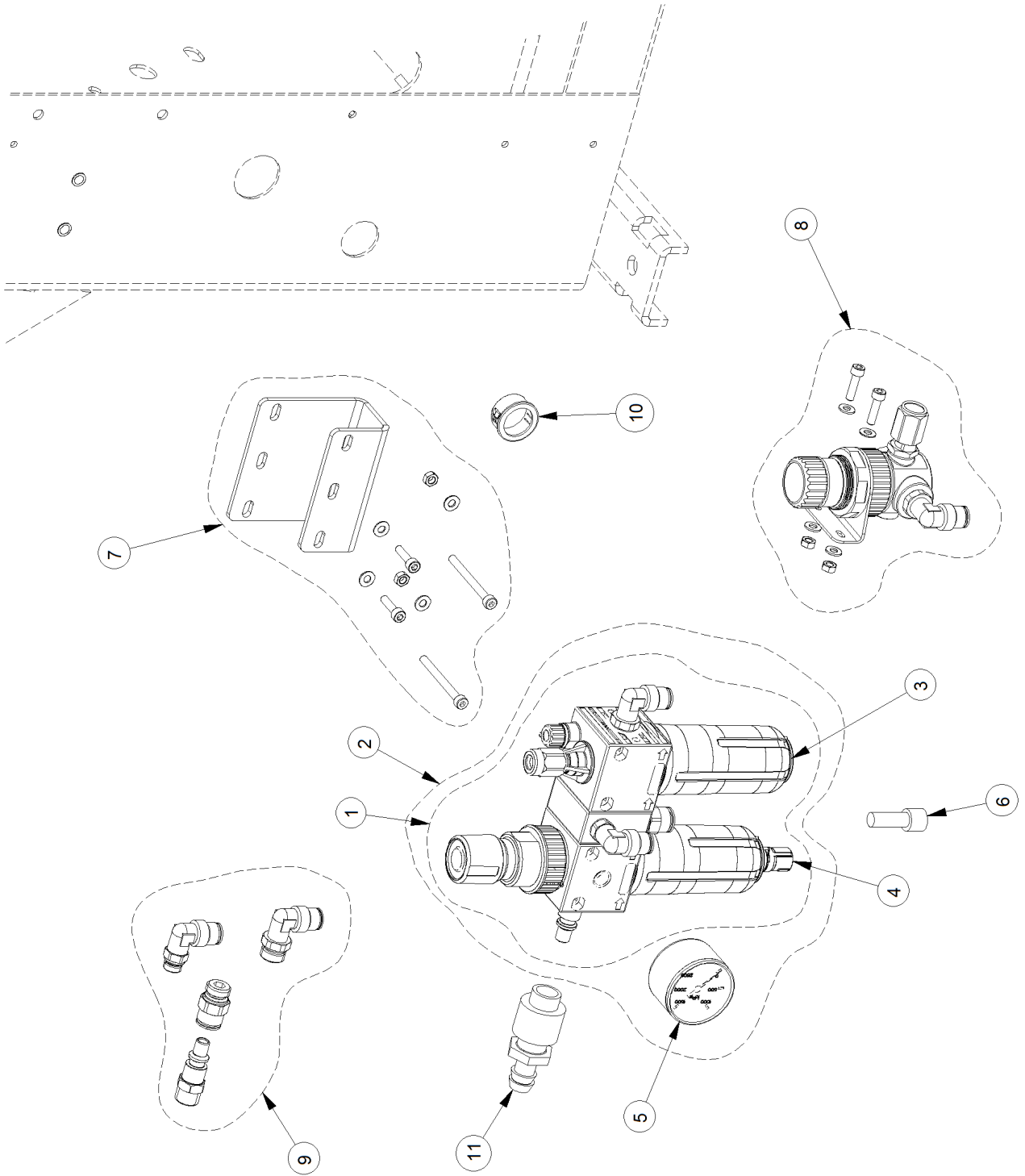

Pos	Code	Designation Designazione ОПИСАНИЕ	Désignation Designación	Bezeichnung Designação	N.	Note Nota HOTa	A	B	C
1	EAA0439G89A	AIR FILTER+LUBRICATOR+PRESS.REG+AIR II GROUPE GRUPPO FILTRO RID. + LUBRIF. AIRIA SINIST ФИЛЬТР+ЛУБРИКАТОР+РЕГУЛЯТОР ДАВЛЕН	FILTRE RED. + LUBRIF AIR GAUCHE GRUPO FILTRO RED. + LUBRIC. AIRE IZQ.	BAUGRUPPE UNTERS.FILTER + ÖLER LUFT LI CONJUNTO FILTRO RED. + LUBRIF. AR ESQU.	1			X	
2	EAA0439G88A	FILTER-PRESS.RED.-LUBRIC.ASSY AIR IN LEF FILTRO RID.+LUBR.ARIA SINISTRA ФИЛЬТР+ЛУБРИКАТОР+РЕГУЛЯТОР ДАВЛЕН	FILTRE RED. + LUBRIF AIR GAUCHE FILTRO RED. + LUBRIC. AIRE IZQ.	UNTERS.FILTER + ÖLER LUFT LINKS FILTRO RED. + LUBRIF. AR ESQU.	1			X	
3	EAC0100G35A	BOWL, OILER COMPLETE VICCHIERE LUBRIFI.COMPL. СТАКАН ЛУБРИКАТОРА	BOL LUBRIFICATEUR COMPLETE VASO LUBRICADOR COMPLETO	SCHAUGLAS, ÖLER COPO LUBRIF. COMPLETO	1		X		X
4	EAC0100G34A	COMPLETE SEPARATOR BOWL VICCHIERE FILTRO COMPLETO СТАКАН ВЛАГООТДЕЛИТЕЛЯ	BOL FILTRE COMPLETE VASO FILTRO COMPLETO	SCHAUGLAS WASSERABSCHIEDER COPO FILTRO COMPLETO	1		X		X
5	8-06420A	MANOMETER D.40 KPA 1/8" MANOMETRO D.40 KPA 1/8" МАНОМЕТР D40 KPA 1/8"	MANOMETRE D.40 KPA 1/8" MANÓMETRO D.40 KPA 1/8"	MANOMETER D.40 KPA 1/8 MANOMETRO KPA	1	(option)		X	
6	EAC0094G49A	CAP, FITTING D.8 TAPPO PER RACCORDI D.8 ЗАГЛУШКА ШТУЦЕРА D 8	BOUCHON POUR RACCORDS D.8 TAPON CONEXIÓN D.8	ABDECKKAPPE, VERSCHRAUBUNG D.8 TAMPA PARA JUNÇÕES D.8	1	(option)	X		
7	EAK0329G18A	FIXING KIT FOR FILTER KIT FISSAGGIO FILTRO Новый комплект крепления фильтра	KIT FIXATION FILTRE KIT DE BLOQUEO FILTRO	FILTER BEFESTIGUNGSSET KIT FIXAÇÃO FILTRO	1	new		X	
8	EAA0408G36A	KIT INFLATION ASSY + FITTINGS + SCREWS KIT LIMITATORE DI GONF. + RACC. + BULLON РЕГУЛЯТОР ПОДКАЧКИ СО ШТУЦЕРАМИ И ВІ	KIT LIMITEUR DE GONF. + RACC. + BOULONNE KIT LIMITADOR HINCHADO + RAC. + BULON.	FÜLLBEGRENZERSSET. + VERSCHR. + BOLZEN KIT LIMITADOR DE INSUFL. + JUNÇÕES + PAR	1	(option)	X		X
9	EAK0315G99A	FITTINGS KIT FOR FILTER KIT RACCORDI PER FILTRO КОМПЛЕКТ ШТУЦЕРОВ ФИЛЬТРА	KIT RACCORDS POUR FILTRE KIT RACORES PARA FILTRO	VERSCHRAUBUNGSSET FILTER KIT JUNÇÕES PARA FILTRO	1		X		X
10	8-11616A	SNAP BUSHING Øe 22.2mm - Øi 17.5mm BOCCOLA AD INNESTO Øe 22.2mm ВТУЛКА	DOUILLE Øe 22.2mm - Øi 17.5mm CASQUILLO	BUCHSE ARRUELA	1	Øe 22.2mm Øi 17.5mm	X		
11	1-13179A	FITTING RACCORDO INN. RAP.F. ШТУЦЕР	RACCORDEMENT CONEXIÓN RAPIDA	VERSCHRAUBUNG JUNÇÃO IN. RAP.F.	1	(steel)	X		

REV	CHANGES - MODIFICHE	DATE	NAME
A	Production release	2015.03.02	N. Castagnoli

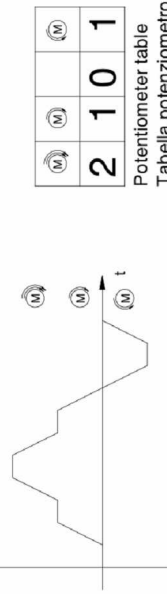
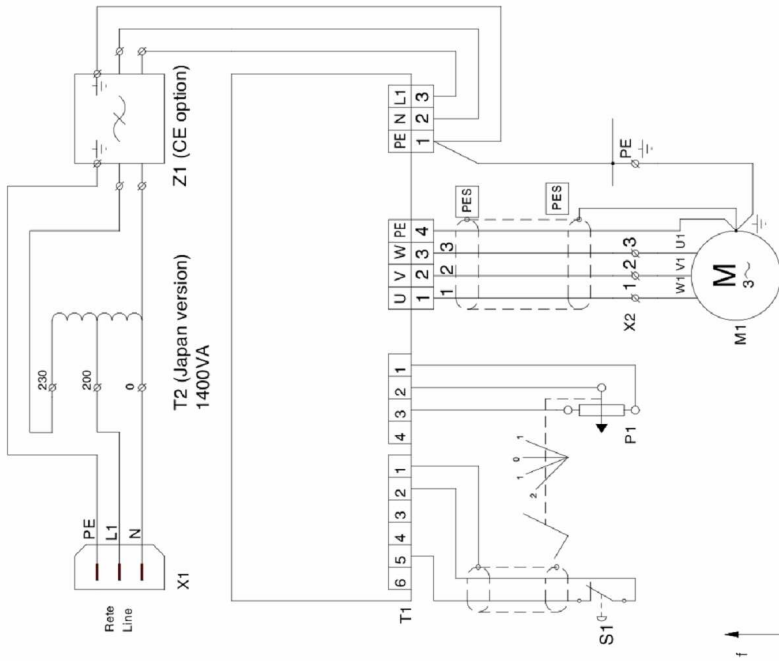

(M)	(M)	(M)	(M)
2	1	0	1

- Potentiometro
Tabella potenziometro
Motore
Interruttore principale
Potenziometro
Pulsante di Stop
Inverter
Trasformatore
Spina di alimentazione
Morseletta motore
Filtro antidisturbo
- M1 Motor
Q1 Main switch
P1 Potentiometer
S1 Stop push button
T1 Inverter
T2 Trasformatore
X1 Main plug
X2 Motor terminal block
Z1 Suppressor

DENOMINAZIONE: SCHEMA ELETTRICO		FAMIGLIA: 824	COD. GS: EEWH556AWD
THE DATA, DRAWINGS AND INFORMATION CONTAINED IN THIS DOCUMENT IS CONFIDENTIAL AND THE SOLE PROPERTY OF SNAP-ON, AND MAY NOT BE REPRODUCED, USED, OR DISCLOSED WITHOUT WRITTEN PERMISSION OF AN OFFICER OF SNAP-ON.			
COPYRIGHT 2015			
MATERIAL		FINISH	
UNLESS OTHERWISE SPECIFIED DIMENSIONS ARE IN MILLIMETERS GENERAL TOLERANCES		CORREGGIO, ITALY	
OVER 0.5 TO 0.0 +0.1		ELECTRIC DIAGRAM	
OVER 0.0 TO 0.30 ± 0.2		PROJ NO TC 22	
OVER 0.3 TO 0.5 ± 0.3		DR N. Castagnoli	
ANGULAR ± 1°		DATE 2015.03.02	
HOLES ± 0.1		CK	
SHEET METAL ± 0.5		APP	
SURFACE: ISO 1302		A3	
FIRST ANGLE PROJECTION		QUALITY DOC	
		RELEASE REV A	
		EEWH556AWD	
		SUPERCEDES	
		SHEET 1 OF 1	

REV	PCN HISTORY
A	15G0057

TEEWH001T
SHEET 1 OF 2

REV _____ DATE _____ NAME _____

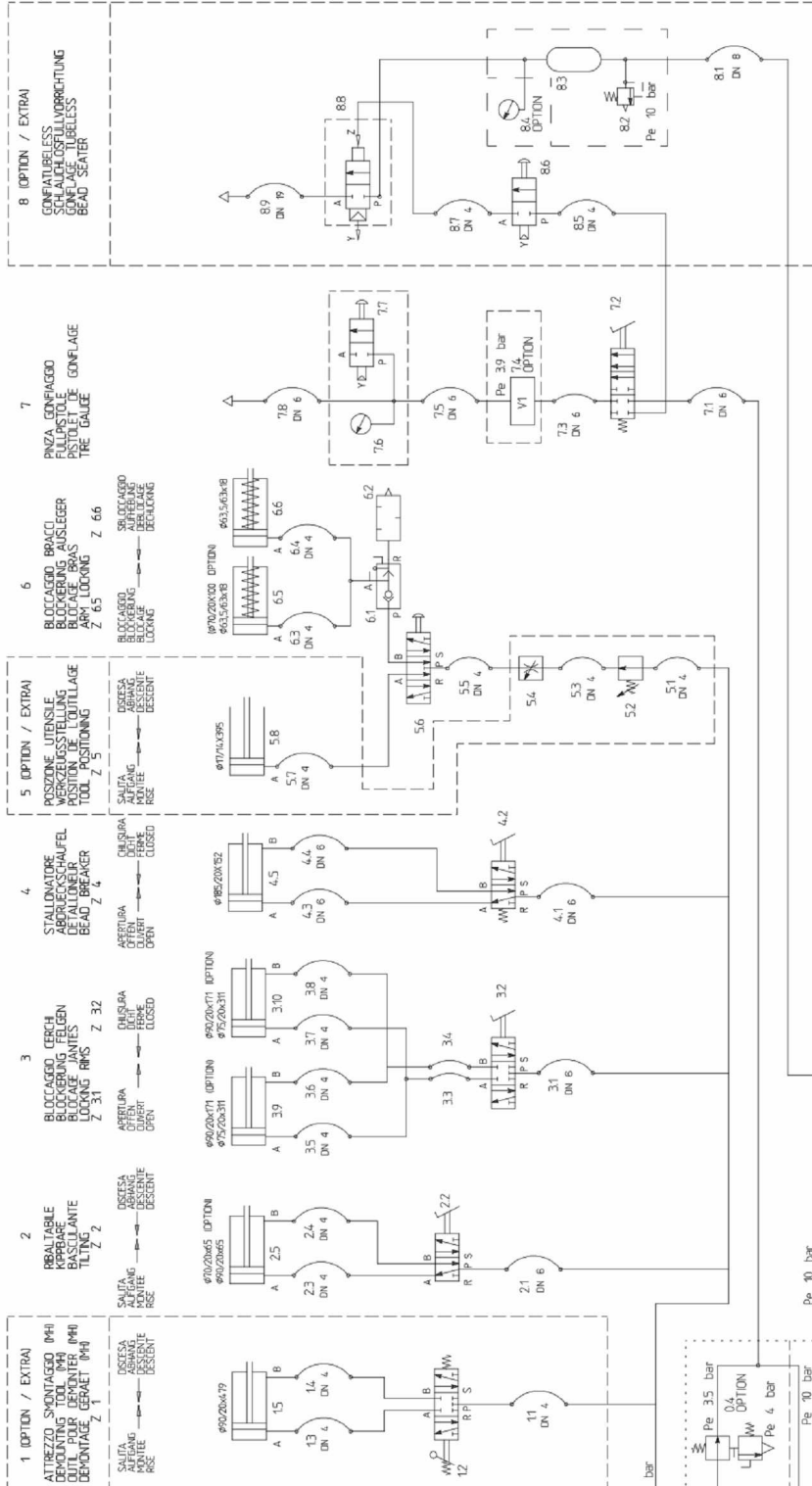

- 0 GRUPPO FILTRO
FILTER GROUP
GRUPPE FÜR
FILTERGRUPP
- 1 (OPTION / EXTRA)
ATTREZZO SMONTAGGIO (M4)
TOOL PIPER (M4)
DEMONTAGE GERÄT (M4)
Z 1
SALITA
AUFGANG
MONTÉE
MONTÉE
DESCENTE
DESCENTE
- 2 RIBALTABILE
REVERSIBLE
GRUPPE FÜR
BASISCHWINGEN
TILTING
Z 2
DESSA
ABWÄRTS
DESCENTE
DESCENTE
- 3 BLOCCAGGIO CERCHI
BLOCKING RIMS
LOCKING RIMS
Z 32
APERTURA
OFFEN
OFFEN
OFFEN
- 4 STALLONATORE
BREAKER
BEAD BREAKER
Z 4
APERTURA
OFFEN
OFFEN
OFFEN
- 5 (OPTION / EXTRA)
POSIZIONE LITENSILE
POSITIONING
TOOL
Z 5
SALITA
AUFGANG
MONTÉE
MONTÉE
DESCENTE
DESCENTE
- 6 BLOCCAGGIO BRACCI
BLOCKING ARMS
ARM LOCKING
Z 66
BLOCCAGGIO
LOCKING
LOCKING
- 7 PINZA GONFIAGGIO
PINCH
CONFEZIONE
PACKAGING
TIRE GAUGE
Z 66
SALITA
AUFGANG
MONTÉE
MONTÉE
DESCENTE
DESCENTE
- 8 (OPTION / EXTRA)
CONFEZIONE
PACKAGING
TIRELESS
BEAD SEATER

V1) VALVOLA LIMITATRICE E DI CONTROLLO DELLA PRESSIONE DI GONFIAGGIO
UTILIZZATA IN ASSENZA DELLA VALVOLA 04
V1) INFLATING PRESSURE LIMITING AND REGISTER VALVE
USED ONLY IF VALVE 04 IS NOT INCLUDED

DEGNOMAZIONE SCHEMA PNEUMATICO SMONTAGGIO TILTING
THE DATA, DIMENSIONS AND INFORMATION CONTAINED IN THIS DOCUMENT IS CONFIDENTIAL AND THE SOLE PROPERTY OF SNAIPAN. NO PART MAY BE REPRODUCED, USED, OR DISCLOSED WITHOUT WRITTEN PERMISSION OF AN OFFICER OF SNAIP-ON

FAMIGLIA	824	COD. GS	0036321
COPYRIGHT	2010		
MATERIAL	CORREGGIO, ITALY		
FINISH			
PROJ NO			
DR			
CK	2010/07/25 M. MARIANI		
A3 APP	RELEASE		
QUALITY DOC	N/A		
SUPERCEDES	N/A		
REV	A		
PCN HISTORY	10050060		
FRST ANGLE PROJECTION	FIRST ANGLE PROJECTION		
TEEWH001T	SHEET 1 OF 2		



8.9	1	TUBO FLESSIBILE	SCHLAUCH	TUYAU FLEXIBLE	FLEXIBLE HOSE	MANULI
8.8	1	VALVOLA A COMANDO PNEUMATICO	VENTIL MIT PNEUM. STEUERUNG	VANNE A COMMANDE PNEUMATIQUE	VALVE WITH PNEUMATIC DRIVE	KPM / AUTEL
8.7	1	TUBO FLESSIBILE	SCHLAUCH	TUYAU FLEXIBLE	FLEXIBLE HOSE	MAZZER
8.6	1	VALVOLA A 2 VIE	ZWEISEITIGE VENTIL	VANNE A 2 VOIES	TWOWAY VALVE	Snap-on
8.5	1	TUBO FLESSIBILE	SCHLAUCH	TUYAU FLEXIBLE	FLEXIBLE HOSE	MAZZER
8.4	1	MANOMETRO	MANOMETER	MANOMETRE	MANOMETER	AIREX
8.3	1	SERBATOIO	TANK	RESRVOIR	TANK	Snap-on / FABBRI
8.2	1	VALVOLA DI SICUREZZA	SICHERHEITSVENTIL	VANNE DE SICURETE	SAFETY VALVE	STIMA
8.1	1	TUBO FLESSIBILE	SCHLAUCH	TUYAU FLEXIBLE	FLEXIBLE HOSE	MAZZER
7.8	1	TUBO FLESSIBILE	SCHLAUCH	TUYAU FLEXIBLE	FLEXIBLE HOSE	MAZZER
7.7	1	VALVOLA A 2 VIE	ZWEISEITIGE VENTIL	VANNE A 2 VOIES	TWOWAY VALVE	Snap-on
7.6	1	MANOMETRO	MANOMETER	MANOMETRE	MANOMETER	WIKA
7.5	1	TUBO FLESSIBILE	SCHLAUCH	TUYAU FLEXIBLE	FLEXIBLE HOSE	MAZZER
7.4	1	AIR CONTROL	AIR CONTROL	AIR CONTROL	AIR CONTROL	Snap-on
7.3	1	TUBO FLESSIBILE	SCHLAUCH	TUYAU FLEXIBLE	FLEXIBLE HOSE	MAZZER
7.2	1	VALVOLA A 4 VIE	VIERSEITIGE VENTIL	VANNE A 4 VOIES	FOURWAY VALVE	Snap-on
7.1	1	TUBO FLESSIBILE	SCHLAUCH	TUYAU FLEXIBLE	FLEXIBLE HOSE	MAZZER
6.6	1	CILINDRO A SEMPLICE EFFETTO	EINFACH WIRKENDE ZYLINDER	VERIN A SIMPLE EFFET	SINGLE EFFECT CYLINDER	Snap-on
6.5	1	CILINDRO A SEMPLICE EFFETTO	EINFACH WIRKENDE ZYLINDER	VERIN A SIMPLE EFFET	SINGLE EFFECT CYLINDER	Snap-on
6.4	1	TUBO FLESSIBILE	SCHLAUCH	TUYAU FLEXIBLE	FLEXIBLE HOSE	MAZZER
6.3	1	TUBO FLESSIBILE	SCHLAUCH	TUYAU FLEXIBLE	FLEXIBLE HOSE	MAZZER
6.2	1	SILENZIATORE	SILENCER	SILENCIEUX	SCHALLDAMPFER	GENERAL CONTROL
6.1	1	VALVOLA DI SCARICO RAPIDO	RAPID EXHAUST VALVE	SOUPAPE D'ECHAPPEMENT RAPIDE	SCHNELLENTLUFTUNGS VENTIL	CAMOZZI
5.8	1	CILINDRO A SEMPLICE EFFETTO	EINFACH WIRKENDE ZYLINDER	VERIN A SIMPLE EFFET	SINGLE EFFECT CYLINDER	Snap-on
5.7	1	TUBO FLESSIBILE	SCHLAUCH	TUYAU FLEXIBLE	FLEXIBLE HOSE	MAZZER
5.6	1	VALVOLA A 5 VIE	FUNFSEITIGE VENTIL	VANNE A 5 VOIES	FIVEWAY VALVE	Snap-on
5.5	1	TUBO FLESSIBILE	SCHLAUCH	TUYAU FLEXIBLE	FLEXIBLE HOSE	MAZZER
5.4	1	VALVOLA REGOLATRICE DI PORTATA	GESCHALTETES STROMREGELVENTIL	REGULATEUR DE DEBIT	FLOW CONTROL VALVE	CAMOZZI
5.3	1	TUBO FLESSIBILE	SCHLAUCH	TUYAU FLEXIBLE	FLEXIBLE HOSE	MAZZER
5.2	1	RIDUTTORE	REDUKTOR	REDUCTEUR	REDUCER	STAMPOTECNICA
5.1	1	TUBO FLESSIBILE	SCHLAUCH	TUYAU FLEXIBLE	FLEXIBLE HOSE	MAZZER
4.5	1	CILINDRO A DOPPIO EFFETTO	DOPPELTWIRKENDER ZYLINDER	VERIN A DOUBLE EFFET	DOUBLE EFFECT CYLINDER	Snap-on
4.4	1	TUBO FLESSIBILE	SCHLAUCH	TUYAU FLEXIBLE	FLEXIBLE HOSE	MAZZER
4.3	1	TUBO FLESSIBILE	SCHLAUCH	TUYAU FLEXIBLE	FLEXIBLE HOSE	MAZZER
4.2	1	VALVOLA A 5 VIE	FUNFSEITIGE VENTIL	VANNE A 5 VOIES	FIVEWAY VALVE	Snap-on
4.1	1	TUBO FLESSIBILE	SCHLAUCH	TUYAU FLEXIBLE	FLEXIBLE HOSE	MAZZER
3.10	1	CILINDRO A DOPPIO EFFETTO	DOPPELTWIRKENDER ZYLINDER	VERIN A DOUBLE EFFET	DOUBLE EFFECT CYLINDER	Snap-on
3.9	1	CILINDRO A DOPPIO EFFETTO	DOPPELTWIRKENDER ZYLINDER	VERIN A DOUBLE EFFET	DOUBLE EFFECT CYLINDER	Snap-on
3.8	1	TUBO FLESSIBILE	SCHLAUCH	TUYAU FLEXIBLE	FLEXIBLE HOSE	MAZZER
3.7	1	TUBO FLESSIBILE	SCHLAUCH	TUYAU FLEXIBLE	FLEXIBLE HOSE	MAZZER
3.6	1	TUBO FLESSIBILE	SCHLAUCH	TUYAU FLEXIBLE	FLEXIBLE HOSE	MAZZER
3.5	1	TUBO FLESSIBILE	SCHLAUCH	TUYAU FLEXIBLE	FLEXIBLE HOSE	MAZZER
3.4	1	TUBO FLESSIBILE	SCHLAUCH	TUYAU FLEXIBLE	FLEXIBLE HOSE	MAZZER
3.3	1	TUBO FLESSIBILE	SCHLAUCH	TUYAU FLEXIBLE	FLEXIBLE HOSE	MAZZER
3.2	1	VALVOLA A 5 VIE	FUNFSEITIGE VENTIL	VANNE A 5 VOIES	FIVEWAY VALVE	Snap-on
3.1	1	TUBO FLESSIBILE	SCHLAUCH	TUYAU FLEXIBLE	FLEXIBLE HOSE	
2.5	1	CILINDRO A DOPPIO EFFETTO	DOPPELTWIRKENDER ZYLINDER	VERIN A DOUBLE EFFET	DOUBLE EFFECT CYLINDER	Snap-on
2.4	1	TUBO FLESSIBILE	SCHLAUCH	TUYAU FLEXIBLE	FLEXIBLE HOSE	MAZZER
2.3	1	TUBO FLESSIBILE	SCHLAUCH	TUYAU FLEXIBLE	FLEXIBLE HOSE	MAZZER
2.2	1	VALVOLA A 5 VIE	FUNFSEITIGE VENTIL	VANNE A 5 VOIES	FIVEWAY VALVE	Snap-on
2.1	1	TUBO FLESSIBILE	SCHLAUCH	TUYAU FLEXIBLE	FLEXIBLE HOSE	MAZZER
1.5	1	CILINDRO A DOPPIO EFFETTO	DOPPELTWIRKENDER ZYLINDER	VERIN A DOUBLE EFFET	DOUBLE EFFECT CYLINDER	Snap-on
1.4	1	TUBO FLESSIBILE	SCHLAUCH	TUYAU FLEXIBLE	FLEXIBLE HOSE	MAZZER
1.3	1	TUBO FLESSIBILE	SCHLAUCH	TUYAU FLEXIBLE	FLEXIBLE HOSE	MAZZER
1.2	1	VALVOLA A 5 VIE	FUNFSEITIGE VENTIL	VANNE A 5 VOIES	FIVEWAY VALVE	STAMPOTECNICA
1.1	1	TUBO FLESSIBILE	SCHLAUCH	TUYAU FLEXIBLE	FLEXIBLE HOSE	MAZZER
0.4	1	RIDUTTORE + VALVOLA DI SICUREZZA	REDUKTOR + SICHERHEITSVENTIL	REDUCTEUR + SOUPAPE DE SICURETE	REDUCER + SAFETY VALVE	STAMPOTECNICA
0.3	1	MANOMETRO	MANOMETER	MANOMETRE	MANOMETER	AIREX
0.2	1	LUBRIFICATORE	SCHMIERVORRICHTUNG	LUBRIFIANT	LUBRIFICATOR	STAMPOTECNICA
0.1	1	FILTRO + RIDUTTORE	FILTER + REDUKTOR	FILTRE + REDUCTEUR	FILTER + REDUCER	STAMPOTECNICA
N.	Q.TA' Stuck Q.TE' Q.TY	DENOMINAZIONE	BENENNUNG	DESCRIPTION	DESCRIPTION	PRODUTTORE HERSTELLER PRODUCTEUR PRODUCER

		PROJ NO. -	SCALE NO	Snap-on Correggio (RE) - ITALY		
		DR MARIANI		PNEUMATIC DIAGRAM FOR TILT T/CHANGER	Release	REV A
		DATE 2010/03/03			TEEWH001T	
A	10G0060	QUALITY DOC -			SHEET 2 OF 2	
REV	PCN HISTORY	SUPERCEDES -				

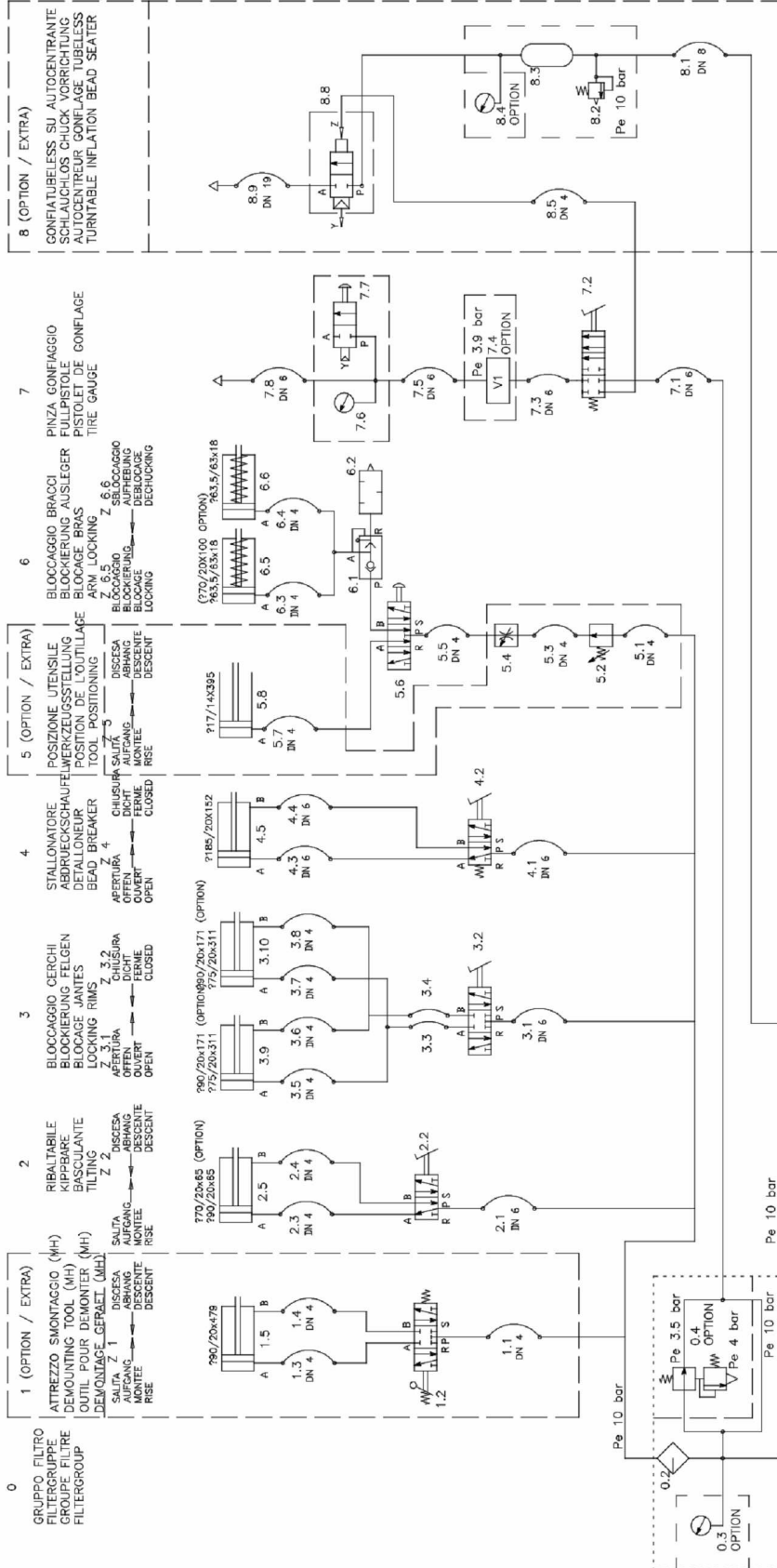

0 GRUPPO FILTRO
FILTERGRUPPE
GROUPE FILTRE
FILTERGROUP

1 (OPTION / EXTRA)
ATTREZZO SMONTAGGIO (MH)
DEMOUNTING TOOL (MH)
OUTIL POUR DEMONTER (MH)
DEMONTAGE GERÄT (MH)

2 RIBALTABILE
KIPPBARE
BASCULANTE
TILTING

3 BLOCCAGGIO CERCHI
BLOCKIERUNG FELGEN
BLOCCAGE JANTES
LOCKING RIMS

4 STALLONATORE
ABDRUECKSCHAUFELE
DÉTALLONNEUR
BEAD BREAKER

5 (OPTION / EXTRA)
POSIZIONE UTENSILE
WERKZEUGSSTELLUNG
POSITION DE L'OUTILLAGE
TOOL POSITIONING

6 BLOCCAGGIO BRACCI
BLOCKIERUNG AUSLEGER
BLOCCAGE BRAS
ARM LOCKING

7 PINZA GONFIAGGIO
FULLPISTOLE
PISTOLET DE CONFLAGE
TIRE GAUGE

8 (OPTION / EXTRA)
CONFIATUBELESS SU AUTOCENTRANTE
SCHLAUCHLOS CHUCK VORRICHTUNG
AUTOCENTREUR CONFLEGE TUBELESS
TURNTABLE INFLATION BEAD SEATER

DENOMINAZIONE: SCHEMA PNEUMATICO SMONTACOMME TILTING 824		FAMIGLIA: 600. 05:
THE DATA, DRAWINGS, AND INFORMATION CONTAINED IN THIS DOCUMENT IS CONFIDENTIAL AND THE SOLE PROPERTY OF SNIP-ON, AND MAY NOT BE REPRODUCED, USED, OR DISCLOSED WITHOUT WRITTEN PERMISSION OF AN OFFICER OF SNIP-ON.		
UNLESS OTHERWISE SPECIFIED DIMENSIONS ARE IN MILLIMETERS GENERAL TOLERANCES OVER 6.5 TO 30 ± 0.1 OVER 30 TO 120 ± 0.3 OVER 120 TO UP ± 0.5 ANGULAR ± 1° HOLES ± 0.1 SHEET METAL ± 0.5 SURFACE: ISO 1302		
CORREGGIO, ITALY		
PNEUMATIC DIAGRAM FOR TILT		
TIRE CHANGER		
RELEASE REV A		
TEEWH003T		
SHEET 1 OF 2		
A3 APP		
QUALITY DOC N/A		
SUPERCEDES N/A		
FIRST ANGLE PROJECTION		
REV PCN HISTORY		
A 12G0268		

V1) VALVOLA LIMITATRICE E DI CONTROLLO DELLA PRESSIONE DI GONFIAGGIO.
UTILIZZATA IN ASSENZA DELLA VALVOLA 0.4.
V1) INFLATING PRESSURE LIMITING AND REGISTER VALVE.
USED ONLY IF VALVE 0.4 IS NOT INCLUDED

8.9	1	TUBO FLESSIBILE	SCHLAUCH	TUYAU FLEXIBLE	FLEXIBLE HOSE	MANULI
8.8	1	VALVOLA A COMANDO PNEUMATICO	VENTIL MIT PNEUM. STEUERUNG	VANNE A COMMANDE PNEUMATIQUE	VALVE WITH PNEUMATIC DRIVE	KPM / AUTEL
8.5	1	TUBO FLESSIBILE	SCHLAUCH	TUYAU FLEXIBLE	FLEXIBLE HOSE	MAZZER
8.4	1	MANOMETRO	MANOMETER	MANOMETRE	MANOMETER	AIREX
8.3	1	SERBATOIO	TANK	RESRVOIR	TANK	Snap-on / FABBRI
8.2	1	VALVOLA DI SICUREZZA	SICHERHEITSVENTIL	VANNE DE SICURETE	SAFETY VALVE	STIMA
8.1	1	TUBO FLESSIBILE	SCHLAUCH	TUYAU FLEXIBLE	FLEXIBLE HOSE	MAZZER
7.8	1	TUBO FLESSIBILE	SCHLAUCH	TUYAU FLEXIBLE	FLEXIBLE HOSE	MANULI
7.7	1	VALVOLA A 2 VIE	ZWEISEITIGE VENTIL	VANNE A 2 VOIES	TWOWAY VALVE	Snap-on
7.6	1	MANOMETRO	MANOMETER	MANOMETRE	MANOMETER	WIKA
7.5	1	TUBO FLESSIBILE	SCHLAUCH	TUYAU FLEXIBLE	FLEXIBLE HOSE	MAZZER
7.4	1	AIR CONTROL	AIR CONTROL	AIR CONTROL	AIR CONTROL	Snap-on
7.3	1	TUBO FLESSIBILE	SCHLAUCH	TUYAU FLEXIBLE	FLEXIBLE HOSE	MAZZER
7.2	1	VALVOLA A 4 VIE	VIERSEITIGE VENTIL	VANNE A 4 VOIES	FOURWAY VALVE	Snap-on
7.1	1	TUBO FLESSIBILE	SCHLAUCH	TUYAU FLEXIBLE	FLEXIBLE HOSE	MAZZER
6.6	1	CILINDRO A SEMPLICE EFFETTO	EINFACH WIRKENDE ZYLINDER	VERIN A SIMPLE EFFET	SINGLE EFFECT CYLINDER	Snap-on
6.5	1	CILINDRO A SEMPLICE EFFETTO	EINFACH WIRKENDE ZYLINDER	VERIN A SIMPLE EFFET	SINGLE EFFECT CYLINDER	Snap-on
6.4	1	TUBO FLESSIBILE	SCHLAUCH	TUYAU FLEXIBLE	FLEXIBLE HOSE	MAZZER
6.3	1	TUBO FLESSIBILE	SCHLAUCH	TUYAU FLEXIBLE	FLEXIBLE HOSE	MAZZER
6.2	1	SILENZIATORE	SILENCER	SILENCIEUX	SCHALLDAMPFER	GENERAL CONTROL
6.1	1	VALVOLA DI SCARICO RAPIDO	RAPID EXHAUST VALVE	SOUPAPE D'ECHAPPEMENT RAPIDE	SCHNELLENTLUFTUNGS VENTIL	CAMOZZI
5.8	1	CILINDRO A SEMPLICE EFFETTO	EINFACH WIRKENDE ZYLINDER	VERIN A SIMPLE EFFET	SINGLE EFFECT CYLINDER	Snap-on
5.7	1	TUBO FLESSIBILE	SCHLAUCH	TUYAU FLEXIBLE	FLEXIBLE HOSE	MAZZER
5.6	1	VALVOLA A 5 VIE	FUNFSEITIGE VENTIL	VANNE A 5 VOIES	FIVEWAY VALVE	Snap-on
5.5	1	TUBO FLESSIBILE	SCHLAUCH	TUYAU FLEXIBLE	FLEXIBLE HOSE	MAZZER
5.4	1	VALVOLA REGOLATRICE DI PORTATA	GESCHALTETES STROMREGELVENTIL	REGULATEUR DE DEBIT	FLOW CONTROL VALVE	CAMOZZI
5.3	1	TUBO FLESSIBILE	SCHLAUCH	TUYAU FLEXIBLE	FLEXIBLE HOSE	MAZZER
5.2	1	RIDUTTORE	REDUKTOR	REDUCTEUR	REDUCER	STAMPOTECNICA
5.1	1	TUBO FLESSIBILE	SCHLAUCH	TUYAU FLEXIBLE	FLEXIBLE HOSE	MAZZER
4.5	1	CILINDRO A DOPPIO EFFETTO	DOPPELTWIRKENDER ZYLINDER	VERIN A DOUBLE EFFET	DOUBLE EFFECT CYLINDER	Snap-on
4.4	1	TUBO FLESSIBILE	SCHLAUCH	TUYAU FLEXIBLE	FLEXIBLE HOSE	MAZZER
4.3	1	TUBO FLESSIBILE	SCHLAUCH	TUYAU FLEXIBLE	FLEXIBLE HOSE	MAZZER
4.2	1	VALVOLA A 5 VIE	FUNFSEITIGE VENTIL	VANNE A 5 VOIES	FIVEWAY VALVE	Snap-on
4.1	1	TUBO FLESSIBILE	SCHLAUCH	TUYAU FLEXIBLE	FLEXIBLE HOSE	MAZZER
3.10	1	CILINDRO A DOPPIO EFFETTO	DOPPELTWIRKENDER ZYLINDER	VERIN A DOUBLE EFFET	DOUBLE EFFECT CYLINDER	Snap-on
3.9	1	CILINDRO A DOPPIO EFFETTO	DOPPELTWIRKENDER ZYLINDER	VERIN A DOUBLE EFFET	DOUBLE EFFECT CYLINDER	Snap-on
3.8	1	TUBO FLESSIBILE	SCHLAUCH	TUYAU FLEXIBLE	FLEXIBLE HOSE	MAZZER
3.7	1	TUBO FLESSIBILE	SCHLAUCH	TUYAU FLEXIBLE	FLEXIBLE HOSE	MAZZER
3.6	1	TUBO FLESSIBILE	SCHLAUCH	TUYAU FLEXIBLE	FLEXIBLE HOSE	MAZZER
3.5	1	TUBO FLESSIBILE	SCHLAUCH	TUYAU FLEXIBLE	FLEXIBLE HOSE	MAZZER
3.4	1	TUBO FLESSIBILE	SCHLAUCH	TUYAU FLEXIBLE	FLEXIBLE HOSE	MAZZER
3.3	1	TUBO FLESSIBILE	SCHLAUCH	TUYAU FLEXIBLE	FLEXIBLE HOSE	MAZZER
3.2	1	VALVOLA A 5 VIE	FUNFSEITIGE VENTIL	VANNE A 5 VOIES	FIVEWAY VALVE	Snap-on
3.1	1	TUBO FLESSIBILE	SCHLAUCH	TUYAU FLEXIBLE	FLEXIBLE HOSE	
2.5	1	CILINDRO A DOPPIO EFFETTO	DOPPELTWIRKENDER ZYLINDER	VERIN A DOUBLE EFFET	DOUBLE EFFECT CYLINDER	Snap-on
2.4	1	TUBO FLESSIBILE	SCHLAUCH	TUYAU FLEXIBLE	FLEXIBLE HOSE	MAZZER
2.3	1	TUBO FLESSIBILE	SCHLAUCH	TUYAU FLEXIBLE	FLEXIBLE HOSE	MAZZER
2.2	1	VALVOLA A 5 VIE	FUNFSEITIGE VENTIL	VANNE A 5 VOIES	FIVEWAY VALVE	Snap-on
2.1	1	TUBO FLESSIBILE	SCHLAUCH	TUYAU FLEXIBLE	FLEXIBLE HOSE	MAZZER
1.5	1	CILINDRO A DOPPIO EFFETTO	DOPPELTWIRKENDER ZYLINDER	VERIN A DOUBLE EFFET	DOUBLE EFFECT CYLINDER	Snap-on
1.4	1	TUBO FLESSIBILE	SCHLAUCH	TUYAU FLEXIBLE	FLEXIBLE HOSE	MAZZER
1.3	1	TUBO FLESSIBILE	SCHLAUCH	TUYAU FLEXIBLE	FLEXIBLE HOSE	MAZZER
1.2	1	VALVOLA A 5 VIE	FUNFSEITIGE VENTIL	VANNE A 5 VOIES	FIVEWAY VALVE	STAMPOTECNICA
1.1	1	TUBO FLESSIBILE	SCHLAUCH	TUYAU FLEXIBLE	FLEXIBLE HOSE	MAZZER
0.4	1	RIDUTTORE + VALVOLA DI SICUREZZA	REDUKTOR + SICHERHEITSVENTIL	REDUCTEUR + SOUPAPE DE SICURETE	REDUCER + SAFETY VALVE	STAMPOTECNICA
0.3	1	MANOMETRO	MANOMETER	MANOMETRE	MANOMETER	AIREX
0.2	1	LUBRIFICATORE	SCHMIERVORRICHTUNG	LUBRIFIANT	LUBRIFICATOR	STAMPOTECNICA
0.1	1	FILTRO + RIDUTTORE	FILTER + REDUKTOR	FILTRE + REDUCTEUR	FILTER + REDUCER	STAMPOTECNICA
N.	Q.TA' Stuck Q.TE' Q.TY	DENOMINAZIONE	BENENNUNG	DESCRIPTION	DESCRIPTION	PRODUTTORE HERSTELLER PRODUCTEUR PRODUCER

		PROJ NO. -	SCALE NO	Snap-on	Correggio (RE) - ITALY	
		DR MANICARDI				
		DATE 2012/07/12		PNEUMATIC DIAGRAM FOR TILT T/CHANGER	Release	REV A
A	12G0268	QUALITY DOC -			TEEWH003T	
REV	PCN HISTORY	SUPERCEDES -			SHEET 2 OF 2	

ENG - DECLARATION OF CE CONFORMITY
FRA - DECLARATION CE DE CONFORMITE
DEU - KONFORMITÄTSERKLÄRUNG
FIN - EY-VAATIMUSTENMUKAISUUSVAKUUTUS
NLD - VERKLARING VAN OVEREENSTEMMING
SWE - EG-FÖRSÄKRAN OM ÖVERENSSTÄMMELSE
DAN - EF-OVERENSSTEMMELSESERKLÆRING
ISL - EB-SAMRÆMISYFIRLÝSING
POL - DEKLARACJA ZGODNOŚCI "CE"
RUM - DECLARAȚIE DE CONFORMITATE CU NORMELE CE
SLO - ES VYHLÁSENIE O ZHODE
SLV - IZJAVA O SKLADNOSTI CE
ALB - DEKLARATË KONFORMITETI KE
HUN - EK MEGFELELŐSÉGI NYILATKOZAT



DICHIARAZIONE CE DI CONFORMITA' - ITA
DECLARAÇÃO CE DE CONFORMIDADE - POR
DECLARACIÓN CE DE CONFORMIDAD - SPA
ДЕКЛАРАЦИЯ ЗА СЪОТВЕТСТВИЕ - BUL
ES PROHLÁŠENÍ O SHODĚ - CES
DEKLARACIJA CE O PODOBNOSTI - HRV
EÜ VASTAVUSDEKLARATSIOON - EST
ΔΗΛΩΣΗ CE ΣΥΜΜΟΡΦΩΣΗΣ - ELL
ES ATBILSTĪBAS DEKLARĀCIJA - LAV
ATITIKTIES DEKLARACIJA - LIT
"EC" ДЕКЛАРАЦИЈА ЗА СООБРАЗНОСТ - MKD
DEKLARACIJA CE O USKLAĐENOSTI - MON
EC UYGUNLUK BEYANNAMESİ - TUR
ДЕКЛАРАЦИЯ СООТВЕТСТВИЯ СТАНДАРТАМ ЕС - RUS

Snap-on Equipment Srl - Via Provinciale per Carpi, 33 - 42015 Correggio (RE) Italy

ENG - takes full responsibility for declaring that the machine:
FRA - déclare sous sa propre responsabilité que la machine :
DEU - erklart auf eigene Verantwortung, dass die Maschine:
ITA - dichiara sotto la propria responsabilità che la macchina:
POR - declara sob a própria responsabilidade que a máquina:
SPA - declara bajo su propia responsabilidad que la máquina:
ALB - deklarón nën përgjegjësinë e tij se makineria:
BUL - декларира под отговорност, че машината:
CES - prohlašuje na vlastní zodpovědnost, že strojní zařízení:
HRV - izjavljuje pod vlastitom odgovornošću da stroj:
DAN - erklærer på eget ansvar, at maskinen:
EST - kinnitab omal vastutusel, et aparaat:
FIN - vakuuttaa omalla vastuullaan, että kone:
ELL - δηλώνει υπεύθυνα ότι η μηχανή:
ISL - lýsir því yfir á eigin ábyrgð að billinn:
LAV - apzinādamies savu atbildību apliecina, ka mašīna/iekārta:
LIT - prisiimdamą atsakomybę skelbia, kad mašina:
MKD - изјавува под своја одговорност дека машината:
MON - izjavljuje pod vlastitom odgovorošću da mašina:
NLD - verklaart voor eigen verantwoordelijkheid dat de machine:
POL - oświadcza na własną odpowiedzialność, że maszyna:
RUM - declară pe propria răspundere că mașina:
SLO - vyhlasuje na vlastnú zodpovednosť, že strojové zariadenie:
SLV - pod lastno odgovornostjo izjavljamo, da je stroj:
SWE - försäkrar under eget ansvar att maskinen:
TUR - kendi sorumluluğu altında makinenin aşağıda belirtilen yöntemlerle uygun olduğunu beyan etmektedir:
HUN - a saját felelőssége tudatában kijelenti, hogy a gép:
RUS - с полной ответственностью заявляет что машина

TIRE CHANGER
DEMONTÉ-PNEUS
REIFENMONTIERMASCHINE
SMONTAGOMME
DEMONTADORA DE PNEUS
DESMONTADOR DE NEUMÁTICOS
ÇMONTUESE GOMASH
МАШИНА ЗА ДЕМОНТАЖ НА ГУМИ
ZOUVAČKA PNEUMATIK
DEMONTIRAČ GUMA
DÆKAFFMONTERINGSMASKINE
REHVIVAHETUSSEADE
RENKAANVAIHTOKONE
ΜΟΧΛΟΣ ΑΦΑΙΡΕΣΗΣ ΑΕΡΟΘΑΛΑΜΟΥ
AFFELGUNARVÉL
RIEPU MONTĀPAS IEKĀRTA
PADANGØ KEITIMO PRIETAISAS
ДЕМОНТИРАЧ НА ГУМИ
DEMONTIRKA GUMA
BANDENLICHTER
URZĄDZENIE DO ZDEJMOWANIA OPON
DISPOZITIV DE DEMONTAT CAUCIUCURI
VYZÚVAČKA PNEUMATIK
SNEMALEC GUM
DÄCKMONTERINGSMASKIN
LASTİK SÖKÜCÜ
GUMISZERELŐ
ШИНОМОНТАЖНЫЙ СТАНОК



EQUIPMENT

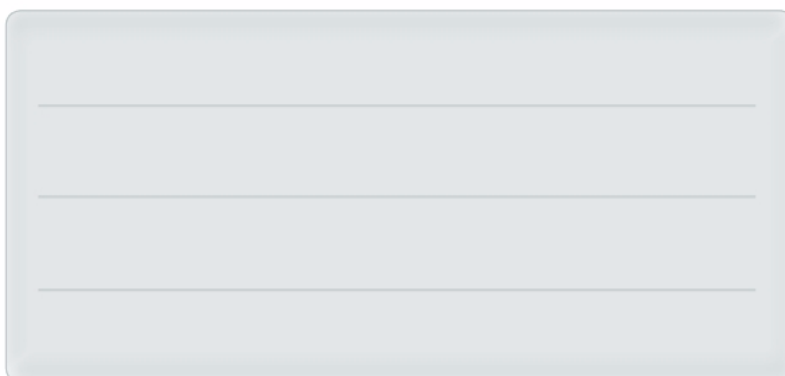

ENG - complies with all the relevant regulations in the following directives:
FRA - est conforme à toutes les dispositions pertinentes des directives suivantes :
DEU - Allen zu folgenden Richtlinien gehörenden Bestimmungen entspricht:
ITA - è conforme a tutte le disposizioni pertinenti delle seguenti direttive:
POR - satisfaz todas as disposições relevantes das seguintes directivas:
SPA - es conforme con todas las disposiciones pertinentes a las siguientes directivas:
ALB - është konform me të gjitha dispozitat që kanë të bëjnë me direktivat e mëposhtme:
BUL - съответства на всички разпоредби, съдържащи се в следващите директиви:
CES - vyhovuje všem požadavkům, které se vztahují na následující směrnice:
HRV - udovoljava svim relevantnim odredbama slijedećih smjernica:
DAN - er i overensstemmelse med bestemmelserne i følgende direktiver:
EST - vastab järgmistele direktiivide kõikidele asjassepuutuvatele sätetele:
FIN - on seuraavien direktiivien asiaankuuluvien säännösten mukainen:
ELL - είναι σύμφωνα με όλες τις προβλέψεις σχετικές με τις ακόλουθες οδηγίες:
ISL - er í samræmi við allar viðeigandi tilskipanir eftirfarandi reglugerða:
LAV - atbilst visiem attiecīgajiem noteikumiem šādās direktīvās:
LIT - atitinka visus toliau nurodytų direktyvų reikalavimus:
MKD - e во согласност со сите норми од следниве директиви:
MON - je u skladu sa svim relevantnim odredbama sledećih direktiva:
NLD - overeenstemt met alle toepasselijke voorschriften van de volgende richtlijnen:
POL - jest zgodna (jest zgodny) ze wszystkimi zarządzeniami zawartymi w następujących dyrektywach:
RUM - este fabricat în conformitate cu toate prevederile în materie din următoarele directive:
SLO - vyhovuje všetkým požiadavkám, vzťahujúcim sa na nasledujúce smernice:
SLV - v skladu z vsemi predpisi, ki se nanašajo na naslednje direktive:
SWE - överensstämmer med alla bestämmelser tillhörande följande direktiv:
TUR - aşağıda belirtilen yönetmeliklere ilişkin tüm hükümlere uygundur:
HUN - megfelel a következő irányelvekbe foglalt, valamennyi rendelkezésnek:
RUS - соответствует всем применяемым нормам следующих директив:

2006/42/EC

2014/30/EU

ENG-The Manager of the Technical Office is authorised to compile a technical leaflet in compliance with appendix VII, letter A, of the 2006/42/CE directive.
FRA-Le Responsable du Bureau Technique est autorisé à constituer le fascicule technique visé sous l'annexe VII lettre A de la directive 2006/42/CE.
DEU-Der Leiter der technischen Abteilung ist bevollmächtigt, die technischen Unterlagen zu erstellen (siehe Anhang VII, Buchstabe A der Richtlinie 2006/42/CE).
ITA-Il Responsabile dell'Ufficio Tecnico è autorizzato a costituire il fascicolo tecnico di cui all'allegato VII lettera A della direttiva 2006/42/CE.
POR-O Responsável do Gabinete Técnico está autorizado a compilar o processo técnico, referido no anexo VII alínea A da directiva 2006/42/CE.
SPA-El Responsable del Departamento Técnico está autorizado a constituir el fascículo técnico indicado en el anexo VII letra A de la directiva 2006/42/CE.
ALB-Përgjegjësi i Zyrës Teknike është i autorizuar të realizojë fashikullin teknik sipas dokumentit bashkëngjitur VII germa A e direktivës 2006/42/KE.
BUL-Отговорникът на Техническият отдел е упълномощен да състави техническата брошура в съответствие с Приложение VII, „А“, Директива 2006/42/ЕС.
CES-Zodpovědný pracovník technického oddělení je oprávněný vypracovat technickou dokumentaci podle přílohy VII části A Směrnice 2006/42/ES.
HRV-Odgovorna osoba Tehničkog ureda je ovlaštena ustrojiti tehnički svezak kako se vidi u dodatku VII slovo A smjernice 2006/42/CE.
DAN-Chefen i den tekniske afdeling har tilladelse til udarbejdelse af den tekniske dokumentation jf. bilag VII litra A i direktivet 2006/42/EF.
EST-Tehnoosakonna vastutav töötaja on volitatud koostama tehnilise toimiku vastavalt direktiivi 2006/42/EÜ VII lisa osale A.
FIN-Teknisen toimiston vastuhenkilö on valtuutettu kokoamaan tekninen eritelmä direktiivin 2006/42/EY liitteen VII kohdan A mukaisesti.
ELL-ΟΥπεύθυνος του Τεχνικού Γραφείου είναι εξουσιοδοτημένος να παράξει τον τεχνικό φάκελο σύμφωνα με το συνημμένο VII γράμμα Α της οδηγίας 2006/42/ΕΚ.
ISL-Ábyrgðarmanni tækniskrifstofunnar er heimilt að gera tækniskjalið samkvæmt A-lið VII. viðauka í reglugerð 2006/42/EB.
LAV-Tehniskās nodaļas vadītājs ir pilnvarots sastādīt tehnisko dokumentāciju atbilstoši ES direktīvas 2006/42/EK VII pielikuma A iedaļai.
LIT-už techninį skyrių atsakingas asmuo yra įgaliotas sudaryti techninę bylą, kurios sudarymo tvarka nurodyta Direktyvos 2006/42/EB VII priedo A dalyje.
MKD-Odgovorniот на техничкиот оддел е овластен да го состави техничкиот прирачник даден во прилог VII писмо А од директивата 2006/42/CE.
MON-Odgovorno lice Tehničkog ureda je ovlašteno da sastavi tehničku fasciklu kako se vidi u dodatku VII slovo A direktive 2006/42/CE.
NLD-Het Hoofd van de Technische Afdeling is gemachtigd om het technisch dossier samen te stellen waarover in Bijlage VII, afdeling A, van de richtlijn 2006/42/EG.
POL-Kierownik Biura Projektowego jest upoważniony do założenia skroszytu technicznego, o którym mowa w Załączniku VII litera A dyrektywy 2006/42/UE.
RUM-Responsabilul Biroului Tehnice este autorizat să întocmească dosarul tehnic prevăzut în anexa VII litera A directiva 2006/42/CE privind echipamentele tehnice.
SLO-Zodpovedný pracovník technického oddelenia je oprávněný vypracovať technickú dokumentáciu podľa prílohy VII časti A Smernice 2006/42/ES.
SLV-Vodja tehničnega urada je pooblaščen za sestavo tehnične mape, kot navedeno v prilogi VII, črka A direktive 2006/42/ES.
SWE-Ansvarig på det tekniska kontoret har behörighet att sammanställa medföljande teknisk dokumentation i enlighet med avsnitt A i bilaga VII i direktiv 2006/42/EG.
TUR-Teknik Ofis Sorumlusu 2006/42/EC Yönetmeliği'nin VII. ekinin A harfinde belirtilen teknik dosyayı hazırlamaya yetkilidir.
HUN-AMűszaki Iroda Irodavezetője feljogosított a 2006/42/EK irányelv Arészének VII. Mellékletében meghatározott, műszaki dokumentáció összeállítására
RUS-Руководитель технического отдела уполномочен составить технический лист в соответствии с приложением VII, литер А директивы 2006/42/CE

ITA-Direttore Operativo SPA-Director Operativo POR-Director Operacional ENG-Operations Manager FRA-Directeur Opérationnel
DEU-Betriebsleiter ALB-Drejtori Operativ BUL-Оперативен директор CES-Výkonný ředitel HRV-Operativni direktor DAN-Driftsleder
EST-Tegevdirektor FIN-Operatiivinen johtaja ELL-Επιχειρησιακός Διευθυντής ISL-Starfandi framkvæmdarstjóri LAV-Operatīvais direktors
LIT-Operacijų vadovas MKD-Оперативен директор MON-Operativni direktor NLD-Operationeel directeur POL-Dyrektor Operacyjny
RUM-Director Operator SLO-Výkonný riaditeľ SLV-Operativni vodja SWE-Driftledare TUR-İşletme Müdürü HUN-Operatív Igazgató
RUS - Управляющий производством

Francesco Frezza

F. Frezza

CE

Correggio (RE) - ITALY

date:



Notice

The information contained in this document is subject to change without notice. Snap-on makes no warranty with regard to this material. Snap-on shall not be liable for errors contained herein or for incidental consequential damages in connection with furnishings, performance, or use of this material.

Snap-on EQUIPMENT



Snap-on Equipment Srl a unico socio

Via Provinciale per Carpi 33,
42015 Correggio (R.E.), Italy
Tel. ++39 (0)522 733480
Fax: ++39 (0)522 733479
E-mail: corrcs@snapon.com
Internet: www.snapon-equipment.eu

copyright 2018