

TECHNICAL DATA

ASPHALT MANAGER 2

BW 154 AP-4I AM, BW 174 AP-4F AM

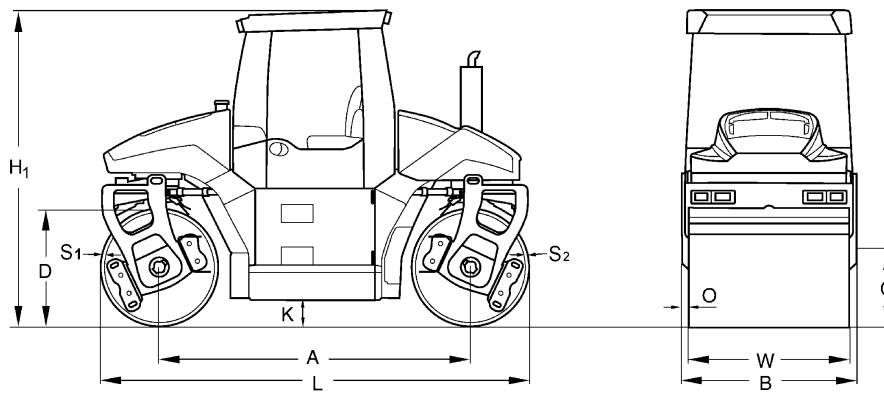



Dimensions in mm

	A	B	C	D	H1	K	L	O	S1	S2	W
BW 154 AP-4I AM	2890	1665	735	1100	2955	240	3990	72	16	16	1500
BW 174 AP-4F AM	3200	1826	660	1220	3000	288	4420	73	19	17	1680

Shipping dimensions in m3

BW 154 AP-4I AM
BW 174 AP-4F AM

with cabin

19,631
 24,213

Machine type	Compaction output (t/h) at different asphalt layer thicknesses		
	2-4	6-8 cm	10-14 cm
BW 154 AP-4I AM	35-70	70-150	100-180
BW 174 AP-4F AM	60-120	110-210	190-300

Technical Data**BOMAG
BW 154 AP-4I AM****BOMAG
BW 174 AP-4F AM****Weights**

Operating weight CECE w. ROPS-cabin	kg	7.300	9.500
Axle load, front / rear CECE	kg	3.750/3.550	5.000/4.500
Static linear load, front / rear CECE	kg/cm	25,0/23,7	29,8/26,8
Grossweight	kg	8.800	11.100

Driving Characteristics

Speed (1)	km/h	0 - 10,0	0- 10,5
-----------------	------	----------	---------

Drive

Engine manufacturer		Kubota	Deutz
Type		V3307 CR-T	TCD 3.6 L4
Emission stage		Stage IIIb / TIER4f	Stage IV / TIER4f
Exhaust gas aftertreatment		DOC+DPF	DPF+SCR
Cooling		water	Liquid
Number of cylinders		4	4
Performance ISO 14396	kW	55,4	74,4
Performance SAE J 1995	hp	74,2	99,6
Speed	min-1	2.400	2.000
Split drum		front + rear	front + rear

Brakes

Service brake		hydrost.	hydrost.
Parking brake		mech.	mech.

Steering

Steering system		2-p. pivoted	2-p. pivoted
Lateral displacement right/left	mm	1.130	1.350

Exciter system

Amplitude	mm	0,66/0,32	0,46/0,20
Frequency	Hz	45/46	45/45
Centrifugal force	kN	88/44	80/34

Vario system

ASPHALT MANAGER		front	front
Frequency	Hz	45	46
Amplitude directed (hor./vert.)	mm	0- 0,80	0,73
Centifugal force	kN	119	146

Capacities

Fuel	l	155,0	180,0
Water	l	550,0	680,0

Technical modifications reserved. Machines may be shown with options.

Standard Equipment

- ECOMODE
- ASPHALT MANAGER
- Oscillation mode
- Plastic water tank under the operator's platform
- Water-saving pressure sprinklers
- 1 Directed exciter, front
- 1 Rotary exciter, rear
- Individual vibration control
- 4 spring-loaded hinged scrapers
- Autom. vibration operation
- Indicator and hazard lights
- ROPS cabin with seat belts + heating
- 2 Outside mirrors
- Steering method/Operator's seat sliding / rotatable
- Steering with comfort control - 5 Steering modes
- Back-up alarm
- Brake release device
- Split drums
- Integrated display(BOP)
- Emergency STOP

Optional Equipment

- Edge cutter
- Rotary beacon
- Special paint
- Environmentally compliant hydraulic oil
- Tool kit
- Precision spreader
- Precision spreader laterally slidable
- Air condition
- Printer for ASPHALT MANAGER
- Radio/Radio preparation
- Lighting for drum edge
- By-pass filter
- Backup warning buzzer with broadband technology
- Additional outside mirrors
- BCM 05 + GPS Documentation system
- Increased amplitude (BW174AP-AM)
- BOMAG TELEMATIC POWER
- Rearview camera
- BOMAG ECOSTOP

