

# Batch Controller

## with numerical keypad and receipt printer driver



### Advantages

- ☑ Save time and cost with the easy to operate numerical keypad.
- ☑ Your crew is in control with our highly praised “know one, know them all” configuration structure, saving time, cost and aggravation.
- ☑ Key information at a glance as the display simultaneously shows actual value, preset value, batch process indication, relay status and measuring units.
- ☑ Easy installation with the rugged aluminum DIN-size panel mount enclosure.

### Features

- ☑ Receipt printing function after each batch.
- ☑ Five control inputs for remote START, HOLD, RESUME, keypad lock and external alarm.
- ☑ 7 large digits for actual value, flow rate, total and 10 smaller digits for preset value, accumulated total and batch count.
- ☑ Selectable on-screen engineering units; volumetric or mass.
- ☑ Power requirements: 24V DC / 110 - 230V AC.
- ☑ Sensor supply: 1.2 / 3 / 8.2 / 12 / 24V DC.
- ☑ No-flow monitoring.
- ☑ Automatic overrun correction.
- ☑ Handheld or panel printers are optional available as accessory.

### Outputs

- ☑ Two field replaceable, heavy duty, mechanical relays (make-and-break/ NO-NC), configurable for i.e. batching with one-stage or two-stage control.
- ☑ Three transistor outputs for connection to PLC's or other controlling equipment.

### Inputs

- ☑ Ability to process various types of volumetric or mass flowmeter signals: Reed-switch, open collector, Namur, NPN, PNP, Sine wave (coil) or active 8/12/24V pulse signals.

### Applications

- ☑ Accurate batching or filling of liquids where the batch size changes frequently and easy ticket printing on location is required.
- ☑ The N413 offers the perfect solution for batch control applications where a user-friendly instrument is required. Whether you focus on its clear display information, the very easy to operate numerical keypad or the easy menu-driven configuration structure, you've got to have a Fluidwell!
- ☑ Alternative basic batch controller with receipt printer driver: [F132](#). For analog inputs we offer our F-Series and D-Series [batch controllers](#). For intrinsically safe applications we offer our field mount [F-Series](#) indicators.

## General information

### Introduction

The N413 batch controller distinguishes itself by its user-friendly features: Numerical keypad, easy ticket printing, clear programming menu structure, easy to read display and simple mounting enclosure. The numerical keypad allows simple and fast changing of the preset batch quantity. Fluidwell stands for simplicity and reliability which is now available in N413.

### Ticket printing

End-of-batch tickets can be printed automatically, manually or after a notification. Multiple reprints are easily executed on demand. Even in the unexpected event of an uncompleted batch, it is possible to print a ticket. An external printing device is necessary, which is available as accessory.

### Display

The unique LCD display provides multiple batch control data at a glance. The main information like actual value, flow rate or batched total are displayed with 7 large digits (14mm, 0.56"). The preset value and units of measure are displayed with 10 smaller segments (8mm, 0.3"). A graphical indication of the batch process and relay status are displayed simultaneously. On-screen engineering units are easily configured in the configuration menu. All values are saved in EEPROM memory. The N413 is standard provided with a bright backlight, which ensures good readings during day and night and it can be adjusted in 6 steps from 0 to 100%.

### Configuration

The N413 uses the same highly appreciated configuration structure as our other product series. Each setting is clearly indicated with an alphanumeric description, eliminating confusing abbreviations. Once familiar with an N-series product, you will be able to program all models in all series without a manual. For example: the configuration menu of the (intrinsically safe) F-Series batch controllers operate almost identical to an N413! In other words: Know one, know them all. Operation and configuration is done via the easy-to-operate numerical keypad. All settings are accessed via a simple operator menu that can be password protected.

### Batch sizes

The preset value of the batched quantity can be programmed fast and easily by the operator via the numerical keypad. Repeating batches are executed, paused and reset easily with a start, hold and reset button.

### Overrun correction

The Fluidwell N413 measures the overrun quantity at the end of every batch. With the automatic overrun correction procedure, the batch is corrected automatically; every run is executed with the highest accuracy.

### Flow meter input

The N413 accepts various input signals for volume flow or mass flowmeters, like reed-switch, open collector, Namur, NPN, PNP, Sine wave (coil) or active 8/12/24V pulse signals.

### No-flow monitor

Following the START command, the flowmeter generates a signal. If this fails to come within the programmed time, an alarm is triggered. The batch is interrupted and the latest process values are stored in the memory. At the same time, the cause of the alarm is displayed. Alarm conditions are indicated visibly and can be configured as an alarm output. The No-flow function detects the absence of liquid, an obstruction in the pipeline or a breakdown.

### Control, Pulse or Alarm outputs

Five outputs are available with the N413: two field replaceable, heavy duty relays and three transistor outputs. Relay 1 is fixed as the main batch control relay. Relay 2 and the transistor outputs can be configured as 1- or 2-stage batch control, alarm or pulse outputs.

### Power requirements

Two power inputs are available to power the N413 and sensor. A 110 - 230V AC and a 24V DC power supply. Both offer an 1.2/3/8.2/12 or 24V DC sensor supply to power the sensor.

### Enclosures

The N413 has an IP67 (Type4X) aluminum DIN size front panel and an IP20 GRP back cover. The removable screw terminal connectors on the back-side and the 4 mounting clamps make the N413 very easy to install.

### Limited depth clearance



### Very easy menu structure



## Receipt information

Standard information printed on the receipt:

- A date- and timestamp.
- Tagnumber.
- Number of completed batches
- Delivered total.
- Accumulated total.

Configurable information printed on the receipt:

- 16 character upper case text header.
- 1 to 9 empty lines before printing the receipt.
- 1 to 9 empty lines after printing the receipt.

## Receipt example

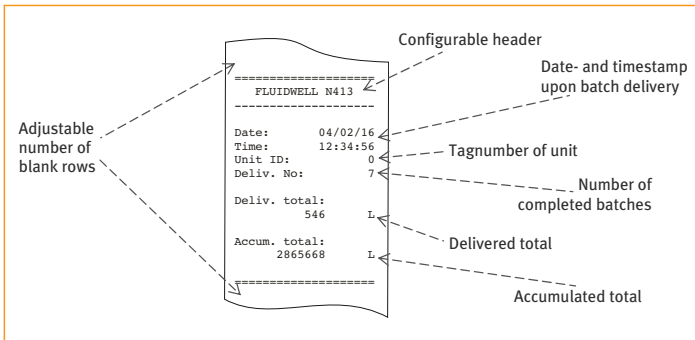

## Printer accessories

An external printing device is necessary, below handheld and panel printers are optional available as accessory.



## Overview application N413

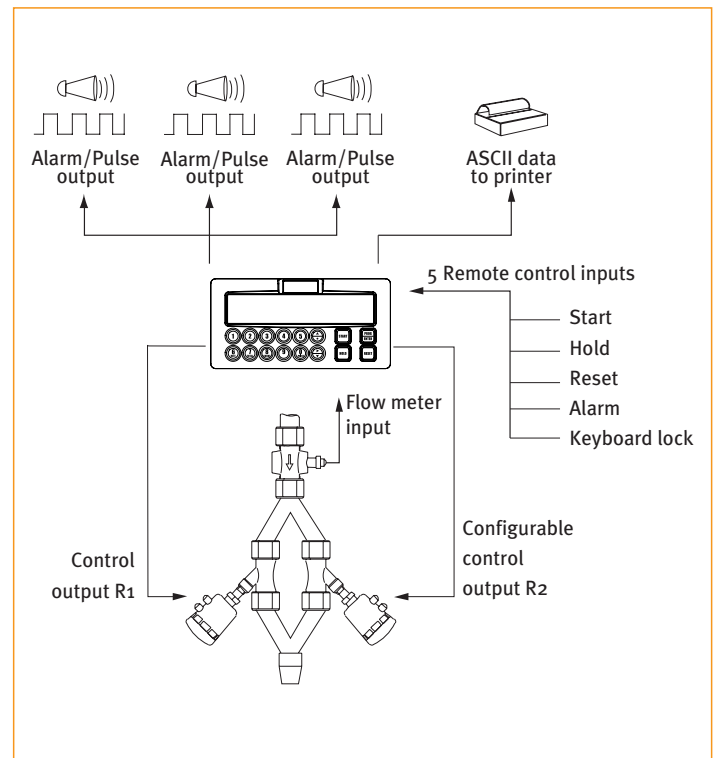

## Terminal connections

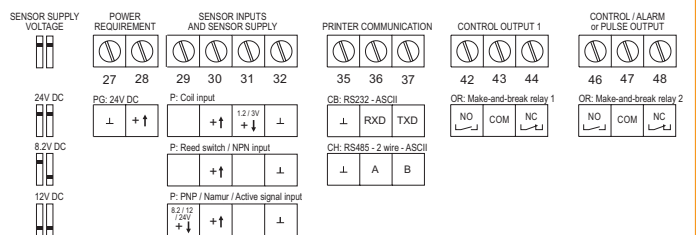
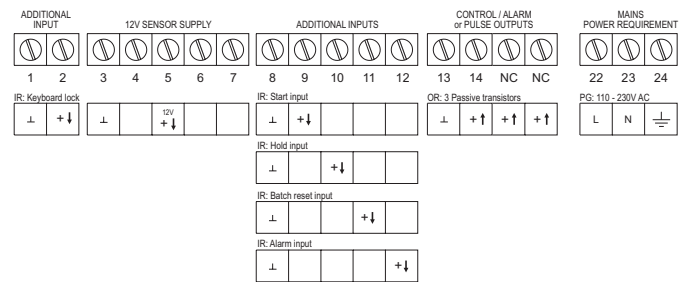

## Display example 1:1 - 22 x 116mm (0.87 x 4.57")

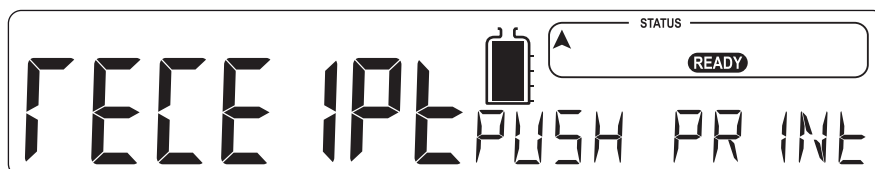

## Dimensions enclosures

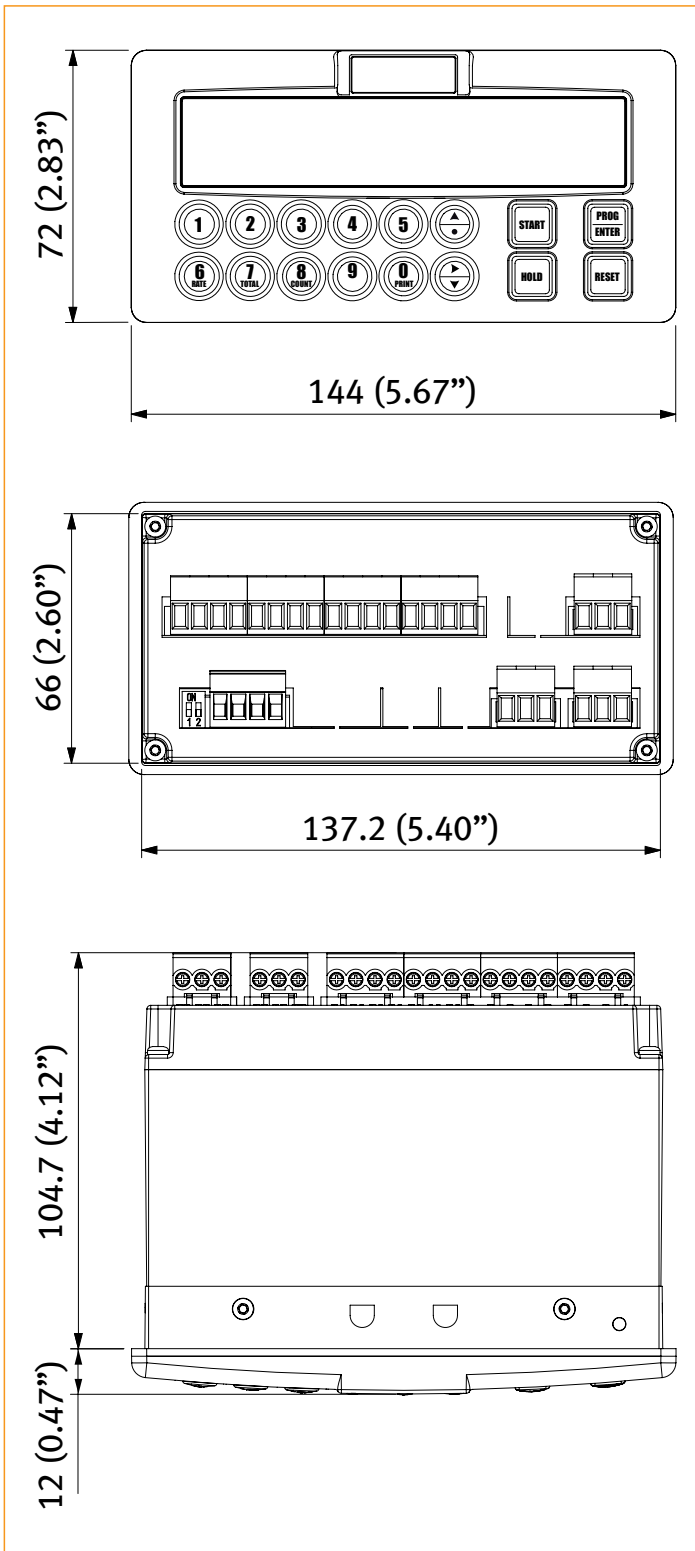

## Panel cut-out

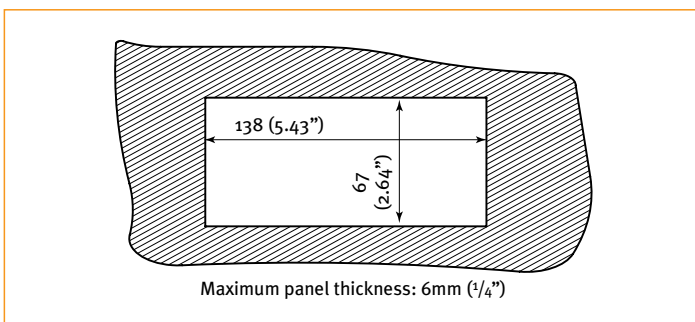

## Wiring example N413-P-CB-IR-OR-PG-ZB

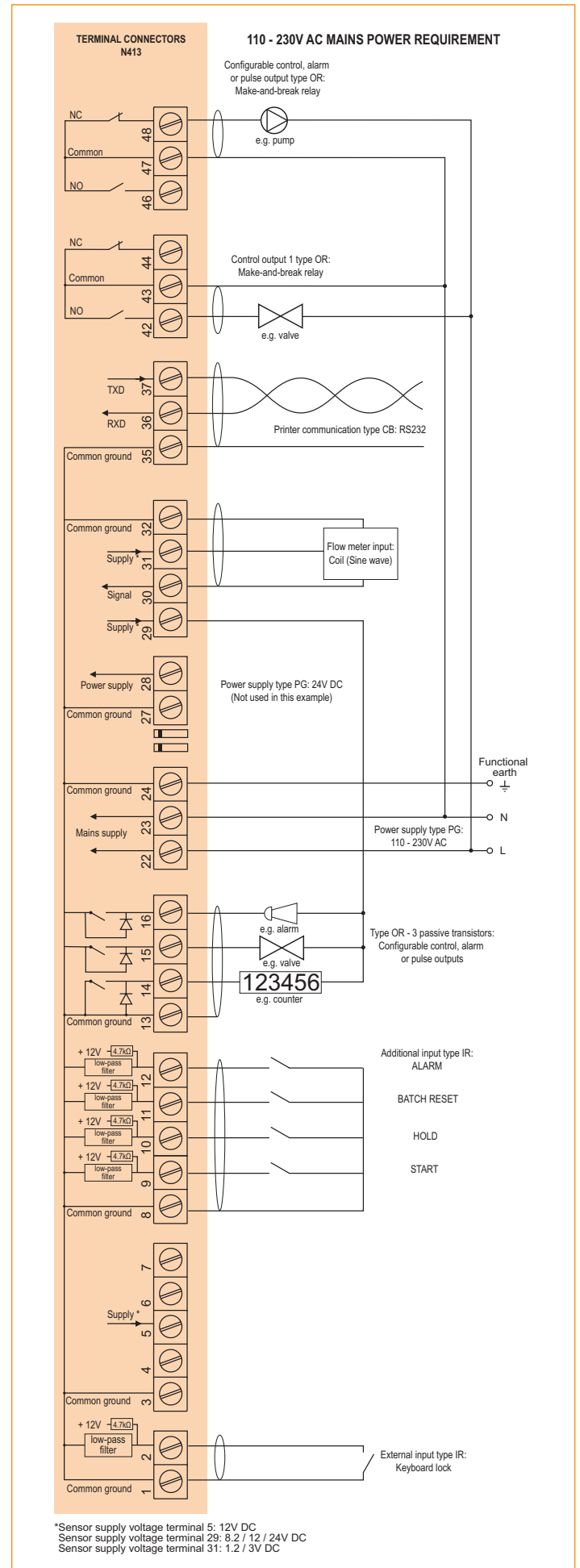



# Technical specification

## General

Display	
Type	High intensity transfective numeric and alpha-numeric LCD, UV-resistant. White LED backlight. Intensity adjustable from 0 – 100% in steps of 20%. Good readings in full sunlight and in darkness.
Dimensions	22 x 116mm (0.87 x 4.57”).
Digits	Seven 14mm (0.56”) and ten 8mm (0.3”) digits. Various symbols and measuring units.
Refresh rate	8 times/sec.

Enclosure	
General	Die-cast aluminum front panel, GRP back enclosure. Polycarbonate window, silicone gasket; UV stabilized and flame retardant material.
Keypad	Sixteen industrial micro-switch keys; UV-resistant silicone keypad; replaceable front.
Painting	UV-resistant 2-component industrial painting.
Dimension	144 x 72 x 110mm (5.67” x 2.83” x 4.33”) – W x H x D.
Classification	IP67 (Type4X) at the front side. IP20 at the back side.
Panel cut-out	138 x 67mm (5.43” x 2.64”) W x H.
Weight	650 gram / 1.7 lbs.
Panel thickness	Max. 6mm (¼”).

Operating temperature / humidity	
Temperature	-20°C to +60°C (-4°F to +140°F).
Storage	-40°C to +80°C (-40°F to +176°F).
Humidity	85% non-condensing, relative.

Power requirements	
Type PG	110 - 230V AC. Power consumption max. 10 Watt. 24V DC ± 10%. Power consumption max. 10 Watt.

Sensor excitation	
Type PG	Terminal 5: 12V DC. $I_{out}$ max. 30mA. Terminal 29: 8.2 / 12 or 24V DC. 8.2V DC, $I_{out}$ max. 20mA. 12V DC, $I_{out}$ max. 30mA. 24V DC, $I_{out}$ max. 75mA. Terminal 31: 1.2 or 3V DC. For sensors with a very low power consumption. (Coil / reed-switch)

Terminal connections	
Type	Removable plug-in terminal strip. Wire max. 2.5mm <sup>2</sup> .

Data protection	
Type	EEPROM backup of all settings. Backup of running totals every minute. Data retention at least 10 years.
Password	Configuration settings can be password protected.
Lock function	Complete keyboard can be locked with external input (e.g. key lock or PLC).

Directives & Standards	
EMC	Directive 2014/30/EU, FCC 47 CFR part 15.
Low voltage	Directive 2014/35/EU.
RoHS	Directive 2011/65/EU.
IP & NEMA	EN 60529 & NEMA 250.

## Signal input

Flowmeter sensor	
Type P	Namur, Coil / sine wave (HI: 20mVpp or LO: 80mVpp, sensitivity selectable), NPN/PNP, open collector, reed-switch, active pulse signals 8 - 12 and 24V DC.
Frequency	Minimum 0Hz - maximum 5kHz for total and flow rate. Maximum frequency depends on signal type and internal low-pass filter. E.g. reed switch with low-pass filter: max. frequency 120Hz.
K-Factor	0.000010 - 9,999,999 with variable decimal position.
Low-pass filter	Available for all pulse signals.
Low Level	0V DC min. to 3V DC max.
High Level	8V DC min. to 24V DC max.
Load impedance	4.7kOhm pull-up to +12V DC.
Current	2.5mA steady state.

Additional inputs	
Function	5 remote control inputs: start, hold, reset, keypad lock and external alarm.
Type IR	Current sinking.
Logic	Level sensitive.
Low Level	0V DC min. to 3V DC max.
High Level	8V DC min. to 24V DC max.
Load impedance	4.7kOhm pull-up to +12V DC.
Current	2.5mA steady state.
Response	100ms make and break time.

## Signal outputs

Digital outputs	
Type OR	<ul style="list-style-type: none"><li>One batch output (always a mechanical relay).</li><li>Four configurable outputs (one mechanical relay and three transistors): batch / two-stage control / any alarm / scaled pulse outputs.</li></ul>
Pulse frequency	Max. 500Hz. Pulse length user definable between 1msec up to 10 seconds.
Relays	2 isolated, field replaceable, electro-mechanical relays (NO-NC). Max. switching capacity (resistive load): 8A @ 250V AC / 30V DC Max. switching power (resistive load): 2000VA 240W.
Transistor	Three passive transistor outputs - not isolated. Load max. 50V DC - 300mA.

Printer communication	
Function	Send a “Print receipt” command after every batch.
Type CB	RS232 - ASCII data.
Type CH	RS485 2-wire - ASCII data.
Speed	1200 - 2400 - 4800 - 9600 - 19200 - 38400 baud.
Addressing	Maximum 255 addresses.
Type CX	No communication, ticket printing is not possible.

# Datasheet N413

Batch Controller for ticket printing



Reliable

*Count on us.*

## Operational

### Operator functions

Functions	<ul style="list-style-type: none"> <li>• Enter a preset value.</li> <li>• Start, hold and stop the batch process.</li> <li>• Total can be reset to zero.</li> <li>• Batch counter can be reset to zero.</li> <li>• End-of-batch ticket printing.</li> </ul>
Displayed functions	<ul style="list-style-type: none"> <li>• Preset value.</li> <li>• Running batch total or remaining quantity.</li> <li>• Flow rate, total and accumulated total.</li> <li>• Batch counter.</li> <li>• Graphical indication progress of the actual batch.</li> </ul>
Additional functions	<ul style="list-style-type: none"> <li>• Active overrun correction.</li> <li>• Minimum / maximum preset value.</li> </ul>

### Preset / Total

Digits	7 digits.
Units	L, m <sup>3</sup> , USGAL, IGAL, ft <sup>3</sup> , bbl, kg, Ton, US Ton, lb.
Decimals	0 - 1 - 2 or 3.
Note	Total can be reset to zero.

### Accumulated total

Digits	10 digits.
Units / decimals	According to selection for preset.
Note	Cannot be reset to zero.

### Batch counter

Digits	10 digits.
Note	Counter can be reset to zero.

### Flow rate

Digits	7 digits.
Units	L, m <sup>3</sup> , USGAL, IGAL, ft <sup>3</sup> , bbl, kg, Ton, US Ton, lb.
Decimals	0 - 1 - 2 or 3.
Time units	/sec - /min - /hr - /day.

## Accessories

### General N-Series accessories & spare parts

ACNo1	Shock proof stainless steel mounting brackets (2pcs).
SRNo1	Spare part: Set of field replaceable relays (2pcs).
SNFo1	Spare part: Aluminum N-Series frontcover

## Ordering information

Standard configuration: N413-P-CB-HB-IR-OR-PG-XX-ZB.

Ordering information: N413	-P	-C	-HB	-IR	-OR	-PG	-XX	-ZB
<b>Flowmeter input signal</b>								
<b>P</b> Coil, NPN, PNP, open collector, Namur, reed-switch, active pulse signals.								
<b>Printer communication</b>								
<b>CB</b> RS232 communication - ASCII data.								
<b>CH</b> RS485 communication - 2-wire - ASCII data.								
<b>CX</b> No communication, ticket printing is not possible.								
<b>Panel mount front enclosure</b>								
<b>HB</b> Aluminum front panel - IP67 (Type4X).								
<b>Additional input signal</b>								
<b>IR</b> Remote control input to start, hold, reset, keypad lock and external alarm.								
<b>Digital output signals</b>								
<b>OR</b> 2 field replaceable, mechanical relays (NO-NC) and 3 passive transistor outputs.								
<b>Power requirements</b>								
<b>PG</b> 24V DC and 110 - 230V AC, with 1.2 / 3 / 8.2 / 12 / 24V DC sensor supply.								
<b>Hazardous area</b>								
<b>XX</b> Safe areas only.								
<b>Other options</b>								
<b>ZB</b> Backlight included as standard.								

The bold marked text contains the standard configuration.



Fluidwell bv  
 P.O. Box 6 • 5460 AA • Veghel  
 Voltaweg 23 • 5466 AZ • Veghel  
 The Netherlands

Telephone: +31 (0) 413 - 343 786  
 Telefax: +31 (0) 413 - 363 443  
 Email: displays@fluidwell.com  
 Internet: www.fluidwell.com



Specifications are subject to change without notice.  
 Copyright: Fluidwell bv - 2016 - N413-DATA-EN-V1618