



VIB HD 56

MEDIUM DEFLECTION MOUNTS

HIGH LOADS

DESCRIPTION

A complete range of high deflection omnidirectional mounts. They are made of two cast iron inserts, a threaded steel plate holding the fixing interfaces is added to one end. The elastomer is a specially developed natural rubber to meet the NAVY requirements (Other materials can be delivered on request).

ADVANTAGES

These mounts will provide both a very high level of vibration attenuation and a high shock capacity to reduce the transmitted acceleration. It's structural resistance correspond to a continuous acceleration of 10 g at the maximum load.

The range is made of several references with a load range ranging from 1125 daN up to 7000 daN per mount.

These mounts meet both the European and North American shock standards.

The metalwork are treated against corrosion.

DIMENSIONS IN mm

(for Shapes 1 & 2)

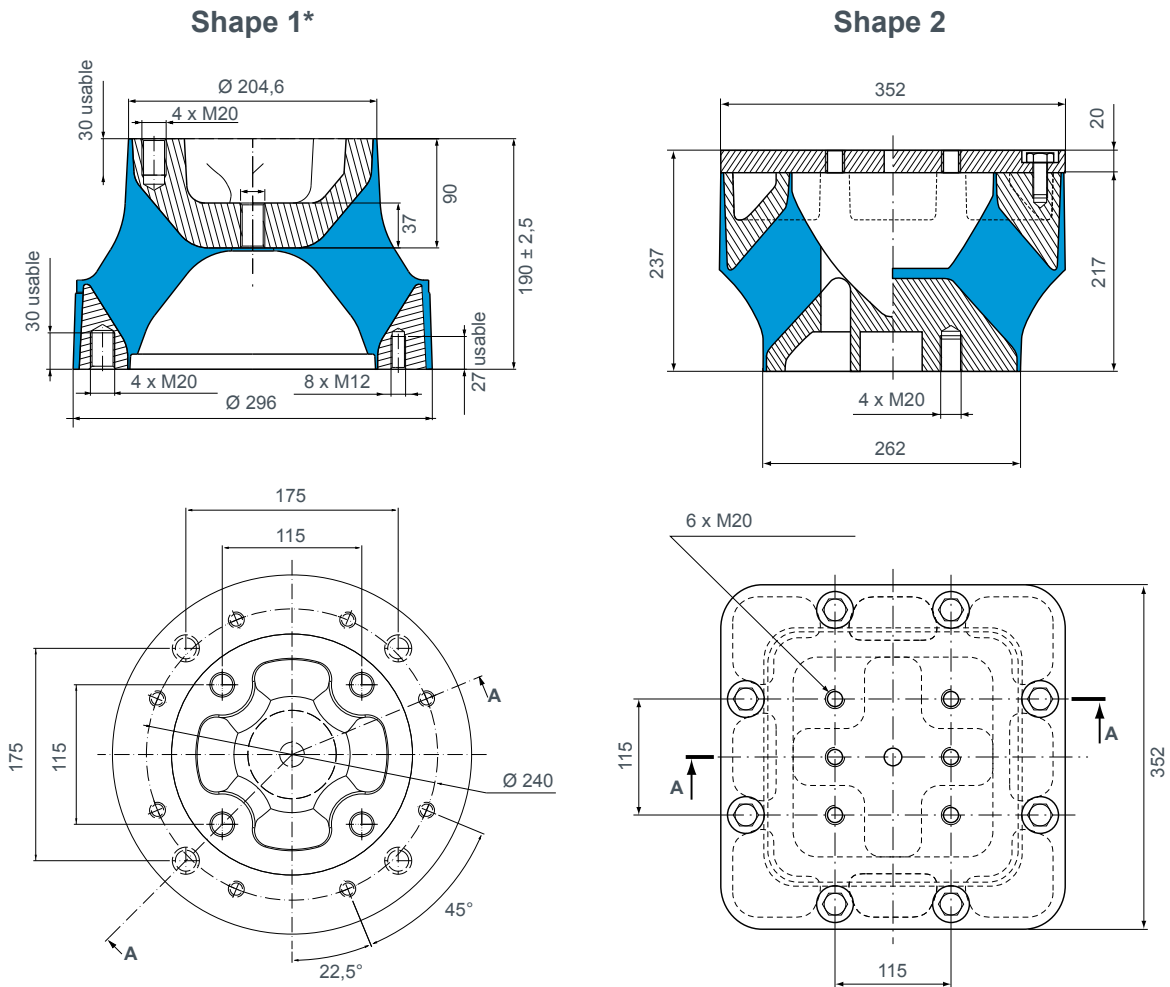

OPERATING CHARACTERISTICS

(for Shapes 1 & 2)

Load range (daN)	Reference	Shape	Height under max. load (mm)
850 to 1955 1050 to 2415 1250 to 2875 1600 to 3680	E1N-4001-54 E1N-4001-52 E1N-4001-53 E1N-4001-51	1	177 ± 2
3000 to 5000 4200 to 7000	E1N-4066-52 E1N-4066-51	2	220 ± 2

- Static nominal load : 1125 to 7000 daN per mount.
- Axial and radial natural frequency : 4 to 7 Hz depending on load.
- Displacement under shock : 56 to 60 mm depending on the axis.
For the E1N-4001mount, it can be increased to 63 mm using spacers.
- Structural strength : 10 g at maximum load.
- Temperature range : - 30°C up to + 80°C.

* Geometry evolution. Please consult us.

ASSEMBLY

These mounts are designed to carry load in compression and should be installed on a smooth surface. The equipment in Men second using 4 M20 bolts (shapes 1 and 2).

For a better result, the load per mount should be evenly distributed. In the case of a tall suspended equipment, these mounts can be used as stabilizing devices. They will be secured to the equipment only after stabilization of the base mount.

These mounts are not designed to carry a permanent load in shear or in tension.

All connections with the suspended equipment must be flexible and capable to accept high displacement allowing the suspensions to work properly.

We strongly recommend to have your installation approved by our technical department before ordering the mounts.

Assembly drawings

