



VIB HD 50

MEDIUM DEFLECTION MOUNTS

LOW LOADS

DESCRIPTION

The permitted deflection (40 to 50 mm) of the suspended mass in relation to the mounting base limits reaction under shock. No efficient vibration protection is offered during shock.

CHARACTERISTICS

- Natural frequency (vertical and lateral) under load of 5 to 8 Hz.
- Maximum deflection under load :
 - vertical : $\pm 50 \text{ mm}^*$;
 - lateral : $\pm 45 \text{ mm}^*$.
- H in rest position.
- H - 6 mm under nominal load (deflection under load = 6 mm).

* maximum forces corresponding to 10 times the load.

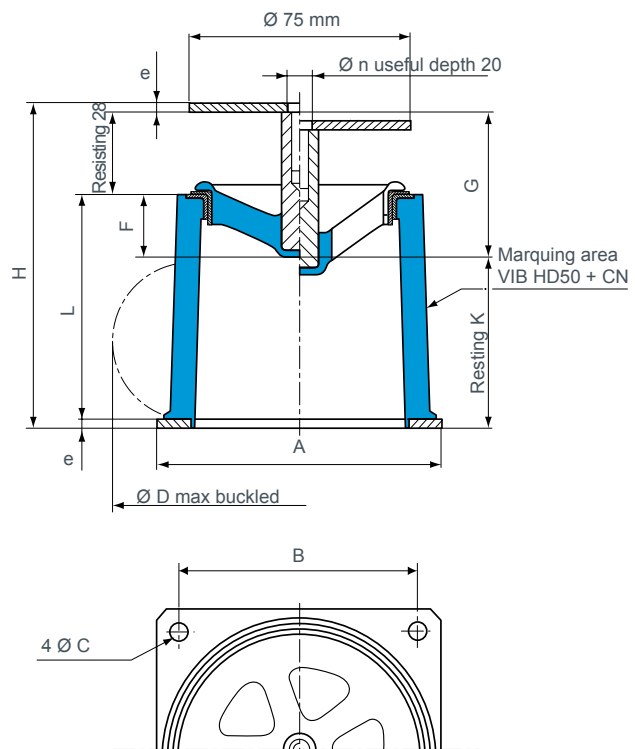

Nominal static load (daN)	Reference	□A (mm)	H (mm)	□B (mm)	e (mm)	Ø C (mm)	Ø n (mm)	F (mm)	G (mm)	Ø D (mm)	L (mm)	K (mm)
1	552301 50	90	109	75	2	5,5	8	19	47	105	77	60
2	552302 50	90	109	75	2	5,5	8	19	47	110	77	60
4	552303 50	95	110	80	3	5,5	8	21	49	120	76	58
8	552304 50	95	110	80	3	5,5	8	21	49	120	76	58
16	552305 50	105	129,5	90	5	6,5	12	39,5	67,5	125	91,5	57
24	552306 50	105	129,5	90	5	6,5	12	39,5	67,5	130	91,5	57
32	552307 50	105	129,5	90	5	6,5	12	39,5	67,5	135	91,5	57