



E1E31 E1E32

SILICONE RUBBER / SPECIAL ELECTRONICS

Natural frequency : (1)
15 to 25 Hz

DESCRIPTION

- VHDS elastomer.
 - Flange and shaft in 18/8 stainless steel.
- Two Ø K fail safe rings must be provided.

APPLICATIONS

- Protecting electronic equipment, navigation equipment, instrument panels, measuring instruments, control panels on aircraft, road vehicles and railway trains.

CHARACTERISTICS

Natural frequency :

- axial : 15 to 25 Hz;
- radial : 20 to 35 Hz.

Maximum permitted excitation at natural frequency of suspension : ± 0.5 mm.

Amplification factor at resonance < 4.

Operating temperature : - 54°C to + 150°C.

Structural strength corresponds to a continuous acceleration of 10 g with maximum load.

Maximum axial travel available for shocks :

E1E 31: ± 4 mm for f min;
 ± 6 mm for f max.

E1E 32 : ± 4.5 mm for f min;
 ± 6 mm for f max.

Weight : E1E31 : 9 g / E1E32 : 25 g.

These mounts meet the standard AIR7304 curve ZF

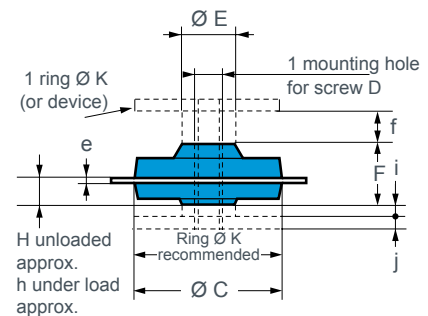
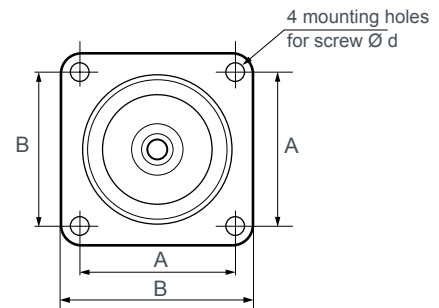

Reference	Axial static loads (daN)	Frequency (Hz)
E1E31S38AL E1E31S55AL E1E31S77AL	0,20 - 0,70 0,30 - 1,00 0,40 - 1,70	15 - 25
E1E32S38AL E1E32S55AL E1E32S77AL	0,30 - 1,10 0,60 - 1,80 0,80 - 2,60	

Reference	A (mm)	B (mm)	Ø C (mm)	D	Ø E (mm)	F (mm)	J (mm)	Ø K (mm)	Ø d (mm)	e (mm)	f (mm)		H (mm)	j (mm)		h (mm)
											Min.	Max.		Min.	Max.	
E1E31S□□AL	25,4	32	25	M4	8,5	10,5	2	25	3,6	1	3,2	5	4,5	0	1,75	3,5
E1E32S□□AL	34,9	44,5	35	M5	13	14,5	3	35	4,3	1,5	4,5	7	6,2	0	2,5	5

1) the indicated natural frequency, are valid for the maxi loads of the ranges of use quoted in the paragraph : TECHNICAL CHARACTERISTICS.

