

Characteristics

	NOMINAL CAPACITY L.min ⁻¹		RELATIVE VACUUM mbar	MOTOR POWER W	ROTATION SPEED rpm		NOISE LEVEL dB(A)		WEIGHT kg
	50 Hz	60 Hz			50 Hz	60 Hz	50 Hz	60 Hz	
PS 2V	47	55	-900	200	1465	1755	57	58	7
PS 5V	81	90	-900	170	1465	1755	57	58	9
PS 7V	106	120	-900	250	1425	1745	57	58	9
PS 12V	168	205	-900	360	1425	1745	57	58	9
PS 5VH	58	66	-980	170	1465	1755	57	58	9
PS 7VH	79	90	-980	250	1425	1745	57	58	9
PS 12VH	123	150	-980	360	1425	1745	57	58	9

Evacuation time curves

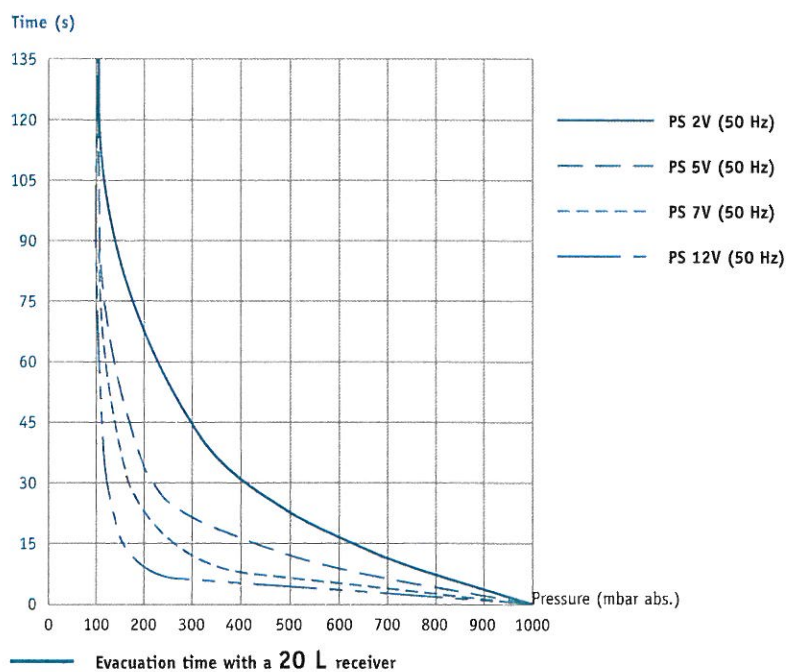

Standard power supply

Electric supply : 1-ph 230V - 50/60 Hz

1
Suction filter with paper, polyester or activated carbon cartridge



2
Check valve

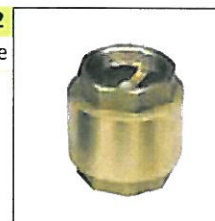

Standard configuration example

- PS piston vacuum pump
- PA suction filter

Oil-free piston vacuum pumps

- Suitable for many types of applications in dry and wet environments
- Oil-free running
- Compact construction and low noise
- Direct coupling
- Low energy consumption
- Optional air filter

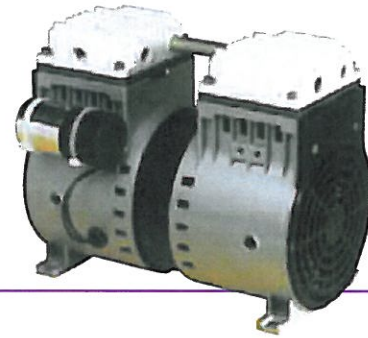

Dimensions

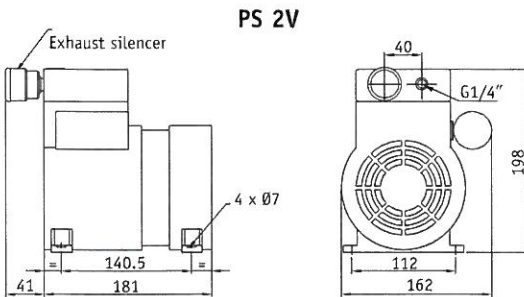

	A	B	D	ØE*	G	H	J**	K
■ PS 5	203,5	240	198	G 1/4"	112	162	40	41
■ PS 7	203,5	240	198	G 1/4"	112	162	40	41
■ PS 12	223	275	242	G 3/8"	118	162	40	52

* : female connection

** : only for V version

PS 5V / PS 7V / PS 12V

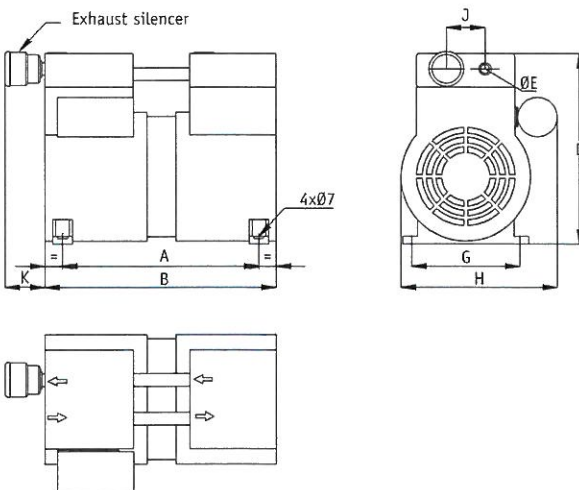

PS 5VH / PS 7VH / PS 12VH

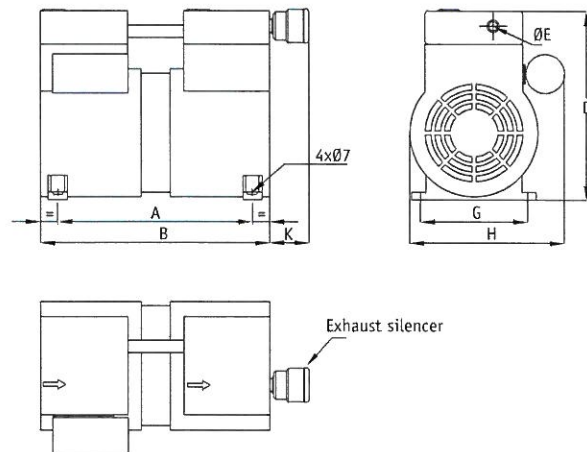

Pump references

	■ PS 2V	■ PS 5V	■ PS 7V	■ PS 12V	■ PS 5VH	■ PS 7VH	■ PS 12VH
1-ph 230V	416082	416083	416085	416094	819903	819904	819905

Accessory and option references

	■ PS 2V	■ PS 5V	■ PS 7V	■ PS 12V	■ PS 5VH	■ PS 7VH	■ PS 12VH
1 Fitted air filter	PA : paper	25PA : 619068		38PA : 619069	25PA : 619068		38PA : 619069
2 Check valve		670175		618996	670175		618996
Adjusting valve and vacuumeter		670176		618997	670176		618997
Atmospheric pressure solenoid valve				359791			
Suction hose		MF 1/4" : 670478		MF 3/8" : 618981	MF 1/4" : 670478		MF 3/8" : 618981

Specifications are subject to be changed without notice